

1.2.1 Tubo oleodinamico

Hydraulic hose



Ricambi & accessori per macchine agricole
SPARE PARTS & ACCESSORIES FOR AGRICULTURAL MACHINE

COME RACCORDARE IL TUBO / HOW TO FIT HYDRULIC HOSE

Scelta del tubo

Il tubo deve essere scelto in base alle esigenze d'uso in funzione della pressione di lavoro (vedi tab. tecnica pag. 3-4-5) ed in relazione alle portate del fluido da convogliare.

Ø I TUBO / HOSE		PORTATA NOMINALE l/min
inch	mm	
3/16"	4,8	8
1/4"	6,3	15
3/8"	9,5	30
1/2"	12,7	40
3/4"	19	80
1"	25,4	135
1"1/4	32	210
1"1/2	38	315
2"	51	450

Misurazione del tubo raccordato

La lunghezza dei tubi flessibili deve essere misurata come nella figura sotto

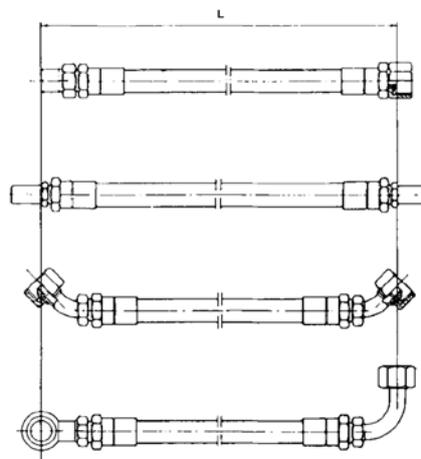

Installazione del tubo

Per ottenere il massimo rendimento ed una lunga durata del tubo occorre applicare lo stesso in modo corretto. Ecco alcuni esempi dei collegamenti maggiormente utilizzati negli impianti idraulici:

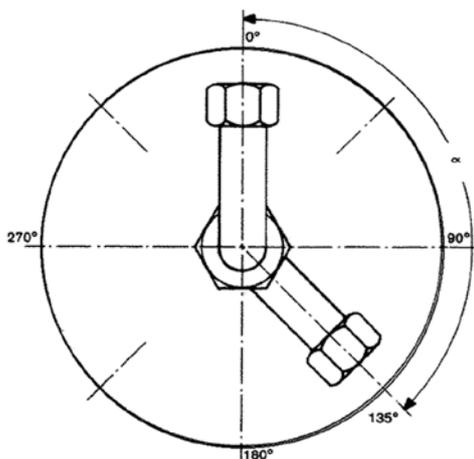
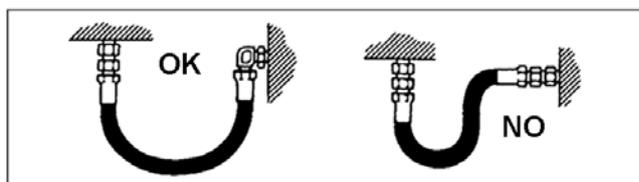
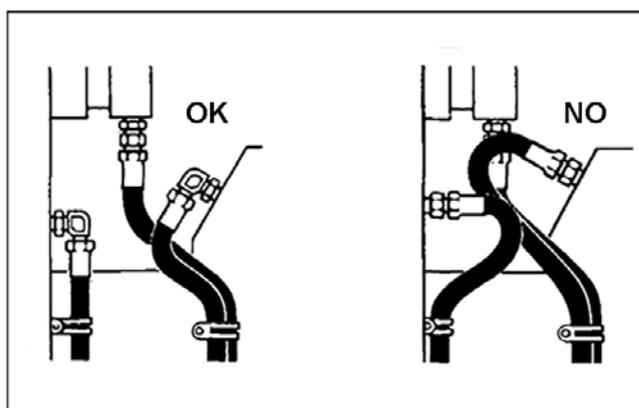
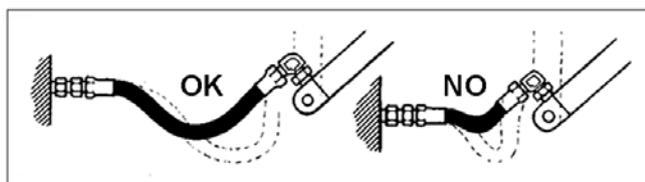
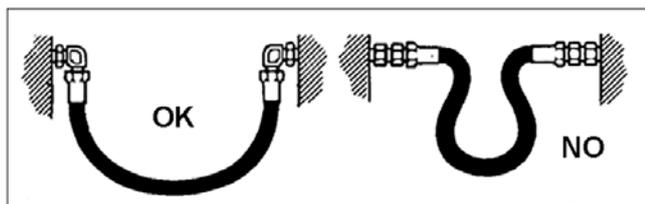
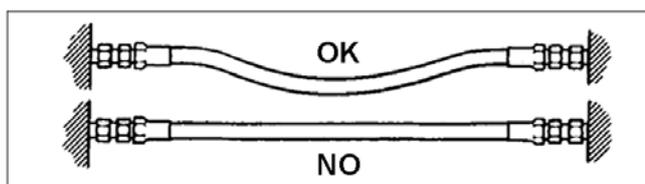

A = ALMENO 6 VOLTE IL DIAMETRO DEL TUBO

B = ALMENO 9 VOLTE IL DIAMETRO DEL TUBO



TABELLA DI COMPARAZIONE (SAE100 - EN 853) / COMPARISON TABLE (SAE100 - EN 853)

Ø	SAE	EN
3/16"	SAE 100 3/16" R1AT	EN 853 1SN DN 5
1/4"	SAE 100 1/4" R1AT	EN 853 1SN DN 6
5/16"	SAE 100 5/16" R1AT	EN 853 1SN DN 8
3/8"	SAE 100 3/8" R1AT	EN 853 1SN DN 10
1/2"	SAE 100 1/2" R1AT	EN 853 1SN DN 12
5/8"	SAE 100 5/8" R1AT	EN 853 1SN DN 16
3/4"	SAE 100 3/4" R1AT	EN 853 1SN DN 19
1"	SAE 100 1" R1AT	EN 853 1SN DN 25
1"1/4"	SAE 100 1"1/4" R1AT	EN 853 1SN DN 32
1"1/2"	SAE 100 1"1/2" R1AT	EN 853 1SN DN 40
2"	SAE 100 2" R1AT	EN 853 1SN DN 50

Ø	SAE	EN
3/16"	SAE 100 3/16" R2AT	EN 853 2SN DN 5
1/4"	SAE 100 1/4" R2AT	EN 853 2SN DN 6
5/16"	SAE 100 5/16" R2AT	EN 853 2SN DN 8
3/8"	SAE 100 3/8" R2AT	EN 853 2SN DN 10
1/2"	SAE 100 1/2" R2AT	EN 853 2SN DN 12
5/8"	SAE 100 5/8" R2AT	EN 853 2SN DN 16
3/4"	SAE 100 3/4" R2AT	EN 853 2SN DN 19
1"	SAE 100 1" R2AT	EN 853 2SN DN 25
1"1/4"	SAE 100 1"1/4" R2AT	EN 853 2SN DN 32
1"1/2"	SAE 100 1"1/2" R2AT	EN 853 2SN DN 40
2"	SAE 100 2" R2AT	EN 853 2SN DN 50

TUBO FLESSIBILE 1SN "REFLUID AGRISTREAM"

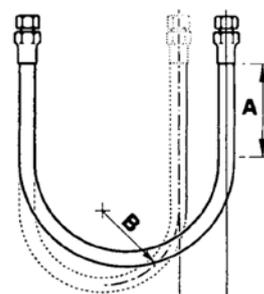
FLEXIBLE 1SN "REFLUID AGRISTREAM"
 HYDRAULIC HOSE 1SN "REFLUID AGRISTREAM"
 HYDR.SCHLAUCH 1SN "REFLUID AGRISTREAM"
 MANGUERA 1SN "REFLUID AGRISTREAM"



Art./Ref.	Ø I inch	Ø I mm	Ø E mm	Pressione max (bar)/ Pression max (bar)	Tipo/Type
89350	1/4"	6,4	13,4	225	1SN
89351	5/16"	7,9	15	215	1SN
89352	3/8"	9,5	17,4	180	1SN
89353	1/2"	12,7	20,6	160	1SN
89355	3/4"	19	27,7	105	1SN
89356	1"	25,4	35,6	88	1SN

TUBO FLESSIBILE 2SN "REFLUID AGRISTREAM"

FLEXIBLE 2SN "REFLUID AGRISTREAM"
 HYDRAULIC HOSE 2SN "REFLUID AGRISTREAM"
 HYDR.SCHLAUCH 2SN "REFLUID AGRISTREAM"
 MANGUERA 2SN "REFLUID AGRISTREAM"



Art./Ref.	Ø I inch	Ø I mm	Ø E mm	Pressione max (bar)/ Pression max (bar)	Tipo/Type
89357	1/4"	6,4	15	400	2SN
89358	5/16"	7,9	16,6	350	2SN
89359	3/8"	9,5	19	330	2SN
89360	1/2"	12,7	22,2	275	2SN
89361	5/8"	15,9	25,4	250	2SN
89362	3/4"	19	29,3	215	2SN
89363	1"	25,4	38,1	165	2SN

TUBO FLESSIBILE COMPACT "REFLUID"

FLEXIBLE COMPACT "REFLUID"
 HYDRAULIC HOSE COMPACT "REFLUID"
 HYDR. SCHLAUCH COMPACT "REFLUID"
 MANGUERA COMPACT "REFLUID"



Art./Ref.	Ø I inch	Ø I mm	Ø E mm	Pressione max (bar)/ Pression max (bar)	Tipo/Type
36847	1/4"	6,4	12,2	225	1SC
36848	3/8"	9,5	15,5	180	1SC
36849	1/2"	12,7	19	160	1SC
06070	1/4"	6,4	13,4	400	2SC
06072	3/8"	9,5	17,1	330	2SC
06073	1/2"	12,7	20,7	275	2SC

TUBO FLESSIBILE PER ALTISSIME PRESSIONI 4SP - 4SH

FLEXIBLE POUR TRES HAUTE PRESSION R9 - R10
 FLEXIBLE HOSE FOR HIGH PRESSURE R9 - R10
 SCHLAUCH FÜR SEHR HOHER DRUCK R9 - R10
 MANGUERA FLEXIBLE PARA ALTISSIMA PRESIÓN



Art./Ref.	Ø I inch	Ø I mm	Ø E mm	Pressione max (bar)/ Pression max (bar)	Tipo/Type
64815	3/8"	9,5	21,2	445	4SP
02338	1/2"	12,7	24,6	415	4SP
16493	5/8"	16	28,2	350	4SP
02341	3/4"	19	32	420	4SH
02342	1"	25,4	39,2	380	4SH
02339	1"1/4"	31,8	50,8	350	4SH
02340	1"1/2"	38,1	56,4	290	4SH

TUBO FLESSIBILE BASSA PRESSIONE PER CIRCUITI OLEODINAMICI

FLEXIBLE HYDRAULIQUE BASSE PRESSION
 LOW PRESSURE HYDRAULIC HOSE
 NIEDERDRUCKHYDRAULIKSCHLAUCH
 MANGUERA HIDRAÚLICA FLEXIBLE DE BAJA PRESIÓN



Art./Ref.	Ø I inch	Ø I mm	Ø E mm	Pressione max (bar)/ Pression max (bar)
06684	3/8"	10	17	10
06685	1/2"	13	20	10
16697	5/8"	16	23	10
06686	3/4"	19	27	10
06687	1"	25	35	10

TUBO FLESSIBILE SAE 100 R4

FLEXIBLE SAE 100 R4
 HYDRAULIC HOSE SAE 100 R4
 HYDR. SCHLAUCH SAE 100 R4
 MANGUERA FLEXIBLE SAE 100 R4



Art./Ref.	Ø I inch	Ø I mm	Ø E mm	Pressione max (bar)/ Pression max (bar)	Tipo/Type
64818	3/4"	19	29	21	R4
64819	1"	25	36	17	R4
64820	1"1/4"	32	43	14	R4
64821	1"1/2"	38	49	10	R4

TUBO FLESSIBILE SAE 100 R6

FLEXIBLE SAE 100 R6
 HYDRAULIC HOSE SAE 100 R6
 HYDR. SCHLAUCH SAE 100 R6
 MANGUERA FLEXIBLE SAE 100 R6



Art./Ref.	Ø I inch	Ø I mm	Ø E mm	Pressione max (bar)/ Pression max (bar)	Tipo/Type
64874	1/4"	6.4	12.3	28	R6
64823	5/16"	8	13.9	28	R6
64824	3/8"	9.5	15.5	28	R6
64825	1/2"	12.7	19	28	R6
64826	5/8"	16	22.6	24	R6
64827	3/4"	19	25.8	21	R6
64828	1"	25.4	33.2	9	R6

TUBO FLESSIBILE SAE100 R7

FLEXIBLE SAE100 R7
 HYDRAULIC HOSE SAE100 R7
 HYDR. SCHLAUCH SAE100 R7
 MANGUERA FLEXIBLE SAE100 R7



Art./Ref.	Ø I inch	Ø I mm	Ø E mm	Pressione max (bar)/ Pression max (bar)	Tipo/Type
12281	3/16"	4.8	10	210	NORMALE / NORMAL
01972	1/4"	6.4	11.8	200	NORMALE / NORMAL
01983	3/8"	9.7	16	175	NORMALE / NORMAL
16617	1/4"	6.4	11.8	200	BINATO / COUPLED

TUBO FLESSIBILE TERMOPLASTICO RINFORZATO

FLEXIBLE THERMOPLASTIQUE RENFORCE'
 THERMOPLASTIC HOSE REINFORCED
 HYDR.SCHL.THERMOPLASTISCHE
 MANGUERA ALTA PRESIÓN TERMOPLÁSTICO RENFORZADA

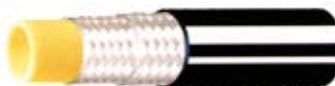

Art./Ref.	Ø I inch	Ø I mm	Ø E mm	Pressione max (bar)/ Pression max (bar)	Tipo/Type
02257	1/4"	6.4	11.9	300	NORMALE / NORMAL
02258	3/8"	9.7	16	225	NORMALE / NORMAL
64814	3/16"	4.8	10	325	BINATO / COUPLED
32951	1/4"	6.4	11.9	300	BINATO / COUPLED
32955	3/8"	9.7	16	225	BINATO / COUPLED

TUBO ALTA PRESSIONE PER IDROPULTRICI

FLEXIBLE HAUTE PRESSION POUR LAVEUSES
 HIGHT PRESSURE HOSE FOR WASHING MACHINES
 SCHLAUCH FÜR HOCHDRUCKREINIGER
 MANGUERA ALTA PRESIÓN PARA MÁQUINAS DE LAVAR



Art./Ref.	Ø I inch	Ø I mm	Ø E mm	Pressione max (bar)/ Pression max (bar)	Temperatura/ Temperature	Tipo/Type
64829	1/4"	6.4	13.2	225	150	HYDRO 1T
06940	5/16"	7.9	15	175	150	HYDRO 1T
06941	3/8"	9.5	17.8	155	150	HYDRO 1T
64830	1/4"	6.4	13.4	400	150	HYDRO 1T
06942	5/16"	7.9	17.5	300	150	HYDRO 2T
06943	3/8"	9.5	19.6	280	150	HYDRO 2T

TUBO ALTA PRESSIONE PER IDROPULTRICI BLU

FLEXIBLE HAUTE PRESSION POUR LAVEUSES
 HIGHT PRESSURE HOSE FOR WASHING MACHINES
 SCHLAUCH FÜR HOCHDRUCKREINIGER
 MANGUERA ALTA PRESIÓN PARA MÁQUINAS DE LAVAR



Art./Ref.	Ø I inch	Ø I mm	Ø E mm	Pressione max (bar)/ Pression max (bar)	Temperatura/ Temperature	Tipo/Type
34223	5/16"	7.9	15	210	150	HYDRO 1T
34224	3/8"	9.5	17.8	210	150	HYDRO 1T
34225	5/16"	7.9	17.5	400	150	HYDRO 2T
34226	3/8"	9.5	19.6	400	150	HYDRO 2T

TUBO RACCORDATO CON RACCORDI DIRITTI DIN 24°

FLEXIBLE RACCORDÉ AVEC RACCORDS DROIT DIN 24°
 HYDRAULIC HOSE WITH DIN 24° STRAIGHT FITTINGS
 SCHLANCH MIT GERADEN ANSCHLÜSSEN DIN 24°
 TUBO RACORDADO CON RACORES RECTOS DIN 24°



Art./Ref.	Ø I inch	Tipo/Type	Lunghezza mm/ Lenght mm	Note/Note
50024	1/4"	2SN	600	DKOL(8)+DKOL(8)
50025	1/4"	2SN	800	DKOL(8)+DKOL(8)
50026	1/4"	2SN	1000	DKOL(8)+DKOL(8)
50027	1/4"	2SN	1200	DKOL(8)+DKOL(8)
50028	5/16"	2SN	600	DKOL(10)+DKOL(10)
50029	5/16"	2SN	800	DKOL(10)+DKOL(10)
50030	5/16"	2SN	1000	DKOL(10)+DKOL(10)
50031	5/16"	2SN	1200	DKOL(10)+DKOL(10)
50032	3/8"	2SN	400	DKOL(12)+DKOL(12)
50033	3/8"	2SN	500	DKOL(12)+DKOL(12)
50034	3/8"	2SN	600	DKOL(12)+DKOL(12)
50035	3/8"	2SN	800	DKOL(12)+DKOL(12)
50036	3/8"	2SN	1000	DKOL(12)+DKOL(12)
50037	3/8"	2SN	1200	DKOL(12)+DKOL(12)
50038	3/8"	2SN	1400	DKOL(12)+DKOL(12)
50039	3/8"	2SN	1600	DKOL(12)+DKOL(12)
50040	3/8"	2SN	1800	DKOL(12)+DKOL(12)
50041	3/8"	2SN	2000	DKOL(12)+DKOL(12)
50042	3/8"	2SN	2500	DKOL(12)+DKOL(12)
50043	3/8"	2SN	3000	DKOL(12)+DKOL(12)
50044	1/2"	2SN	400	DKOL(15)+DKOL(15)
50045	1/2"	2SN	500	DKOL(15)+DKOL(15)
50046	1/2"	2SN	600	DKOL(15)+DKOL(15)
50047	1/2"	2SN	800	DKOL(15)+DKOL(15)
50048	1/2"	2SN	1000	DKOL(15)+DKOL(15)
50049	1/2"	2SN	1200	DKOL(15)+DKOL(15)
50050	1/2"	2SN	1400	DKOL(15)+DKOL(15)
50051	1/2"	2SN	1600	DKOL(15)+DKOL(15)
50052	1/2"	2SN	1800	DKOL(15)+DKOL(15)
50053	1/2"	2SN	2000	DKOL(15)+DKOL(15)
50054	1/2"	2SN	2500	DKOL(15)+DKOL(15)
50055	1/2"	2SN	3000	DKOL(15)+DKOL(15)

TUBI RACCORDATI CON RACCORDI DIRITTI E RACCORDI A 90° DIN 24°

FLEXIBLE RACCORDÉ AVEC RACCORDS A 90° SIN 24°
 HYDRAULIC HOSE WITH DIN 24° STRAIGHT FITTINGS AND 90° DIN 24° FITTINGS
 SCHLANCH MIT 90°- ANSCHLÜSSEN DIN 24°
 TUBO RACORDADO CON RACORES A 90° DIN 24°



Art./Ref.	Ø I inch	Tipo/Type	Lunghezza mm/ Lenght mm	Note/Note
50056	3/8"	2SN	600	DKOL(12)+DKOL 90°(12)
50057	3/8"	2SN	800	DKOL(12)+DKOL 90°(12)
50058	3/8"	2SN	1000	DKOL(12)+DKOL 90°(12)
50059	3/8"	2SN	1200	DKOL(12)+DKOL 90°(12)
50060	3/8"	2SN	1400	DKOL(12)+DKOL 90°(12)
50061	3/8"	2SN	1600	DKOL(12)+DKOL 90°(12)
50062	1/2"	2SN	600	DKOL(15)+DKOL 90°(15)
50063	1/2"	2SN	800	DKOL(15)+DKOL 90°(15)
50064	1/2"	2SN	1000	DKOL(15)+DKOL 90°(15)
50065	1/2"	2SN	1200	DKOL(15)+DKOL 90°(15)
50066	1/2"	2SN	1400	DKOL(15)+DKOL 90°(15)
50067	1/2"	2SN	1600	DKOL(15)+DKOL 90°(15)
84539	1/2"	2SN	2000	DKOL(15)+DKOL 90°(15)

KIT TUBI DI COLLEGAMENTO PER 3° PUNTI IDRAULICI

KITS DE FLEXIBLES POUR 3ÈMES POINTS HYDRAULIQUES, COMPLETS AVEC COUPLEURS.
 HOSES KIT FOR HYDRAULIC TOP LINKS, COMPLETE WITH COUPLINGS.
 SATZ KPL. HYDRAULISKSCHLÄUCHE FÜR HYDRAULISCHE OBERLENKER.
 KIT TUBOS PARA TERCER PUNTOS HYDRAULICOS CON EMBRAGUES RÁPIDOS



Art./Ref.	Ø I inch	Tipo/Type	Lunghezza mm/ Lenght mm	Note/Notes
04559	3/8"	2SN	900	2 tubi 3/8" 2SN con F90 completa di nipples 3/8" + innesto rapido maschio a valvola da 1/2" L.900mm / 2 crimping hoses with F90° + 3/8" nipple and male poppet quick coupling 1/2" L.900mm
04560	3/8"	2SN	900 / 1400	1 tubo 3/8" 2SN con F90 completa di nipples 3/8" + innesto rapido maschio a valvola da 1/2" L.900mm e 1 L.1400mm / 1 crimping hose with F90° + 3/8" nipple and male poppet quick coupling 1/2" L.900mm and 1 L.1400mm
67852	3/8"	2SN	900	1 tubo 3/8" 2SN con F90 completa di nipples 3/8" + innesto rapido maschio a valvola da 1/2" L.900mm / 1 crimping hose with F90° + 3/8" nipple and male poppet quick coupling 1/2" L.900mm and 1 crimping hose with banjo and screw bolt and male poppet quick coupling 1/2" L.900mm

GUAINA DI PROTEZIONE PER TUBO OLEODINAMICO

ENVELOPPE PROTÉCTRICE POUR FLEXIBLE
 PROTECTIVE COVERING FOR HYDRAULIC HOSE
 SCHUTZHÜLLE FÜR HYDRAULIC SCHLÄUCHE
 REVESTIMIENTO DE PROTECCIÓN PARA TUBO OLEODINÁMICO



Art./Ref.	Ø I mm	Materiale/ Material	Note/Note
12305	16	PVC	1/4"
12306	20	PVC	5/16"
12307	22	PVC	3/8"
12308	25	PVC	1/2"
12309	30	PVC	3/4"
12310	38	PVC	1"

SPIRALE IN PVC

SPIRALE DE PROTECTION EN PVC
 PVC SPIRAL PROTECTION
 SCHUTZSPIRALE FÜR SCHLAUCH AUS PVC
 ESPIRAL DE PROTECCION IN PVC



Art./Ref.	Ø I mm	Ø E mm	Note/Note
16063	13	16.2	DA 3/16" A 1/4"
16064	16	19.5	DA 1/4" A 1/2"
84758	20	25	da 5/16" a 3/8"
84759	24	29	da 3/8" a 1/2"
16065	27	32.2	DA 5/8" A 3/4"
84518	35	40	1"
16066	43.5	49.5	DA 1"1/4" A 1"1/2"
16067	64	72.5	2"
16068	81	91	-

GUAINA TESSILE

GAINÉ EN TISSU
 TEXTILE PROTECTION
 TEXTIL-HUELLE
 FONDA TEXTIL



Art./Ref.	Ø I mm	Ø E mm	Note/Note
61449	20	35	1/4" - 5/16"
61450	22	40	3/8"
61451	28	50	1/2"
61452	32	55	3/4"
61453	45	80	1" - 1"1/4"

1.2.2 Raccorderia e innesti rapidi

Hose & quick release coupling



Ricambi & accessori per macchine agricole

SPARE PARTS & ACCESSORIES FOR AGRICULTURAL MACHINE

Tutti gli articoli della presente sezione, prodotti da AMA SPA e/o da terzi per conto di AMA, sono adattabili ("non originali") alle marche indicate ai sensi di quanto previsto dal REG. CE n. 1400/2002. I diritti sui marchi citati appartengono ai legittimi proprietari ed il loro uso ha l'esclusiva finalità di consentire all'utilizzatore la comparazione dei diversi prodotti. All items of this section, manufactured by AMA SPA and/or any third party on behalf of AMA, are adaptable ("non-original") to the brands listed under the provisions of the REG. CE n. 1400/2002. The rights on the trademarks belong to their respective owners and their usage is only aimed to allow the user to compare different products.

BOCCOLA A PRESSARE PER TUBO SAE100 R1A - EN 853 1ST SKIVE

DOUILLES POUR FLEXIBLE SAE100 R1A - EN 853 1ST SKIVE
 FERRULE FOR HYDR. HOSE SAE100 R1A - EN 853 1ST SKIVE
 SCHLAUCH HÜLSEN ZUM PRESSEN SKIVE
 CASQUILLAS PARA RACORES DE TUBO DE ALTA PRESIÓN SKIVE

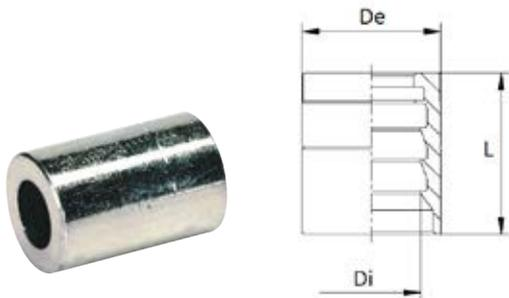

Art./Ref.	Ø interno inch/ Inside Ø inch	Ø esterno mm/ Outside Ø mm	Ø interno mm/ Inside Ø mm	Lunghezza mm/ Lenght mm
04680	1/4"	19	12,7	25,5
04681	5/16"	21	14	26,5
04682	3/8"	23	16,3	27
04683	1/2"	28	19,8	29

BOCCOLA A PRESSARE PER TUBO SAE100 R2A - EN 853 2ST SKIVE

DOUILLES POUR FLEXIBLE SAE100 R2A - EN 853 2ST SKIVE
 FERRULE FOR HYDR. HOSE SAE100 R2A - EN 853 2ST SKIVE
 SCHLAUCH HÜLSEN ZUM PRESSEN SAE100 R2A - EN 853 2ST SKIVE
 CASQUILLAS PARA RACORES DE TUBO DE ALTA PRESIÓN SAE100 R2A - EN 853 2ST SKIVE

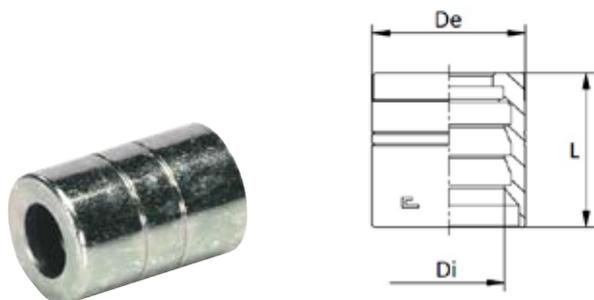
TUBO SAE100 R2A - EN 853 2ST

Art./Ref.	Ø interno inch/ Inside Ø inch	Ø esterno mm/ Outside Ø mm	Ø interno mm/ Inside Ø mm	Lunghezza mm/ Lenght mm
04700	1/4"	20	13,7	25,5
04701	5/16"	23	15,6	26,5
04702	3/8"	24,5	17,8	27
04703	1/2"	29	21,3	29
04705	3/4"	37	28,5	36
04706	1"	45	35,8	44,5
04707	1"1/4"	55	45,2	48

BOCCOLA A PRESSARE PER TUBO SAE100 R1AT - EN 853 1SN NO SKIVE

DOUILLES POUR FLEXIBLE SAE100 R1AT - EN 853 1SN NO SKIVE
 FERRULE FOR HYDR. HOSE SAE100 R1AT - EN 853 1SN NO SKIVE
 SCHLAUCH HÜLSEN ZUM PRESSEN SAE100 R1AT - EN 853 1SN NO SKIVE
 CASQUILLAS PARA RACORES DE TUBO DE ALTA PRESIÓN NO SKIVE

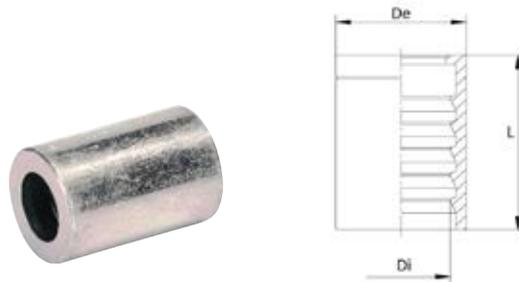

Art./Ref.	Ø interno inch/ Inside Ø inch	Ø esterno mm/ Outside Ø mm	Ø interno mm/ Inside Ø mm	Lunghezza mm/ Lenght mm
67491	3/16"	18	12,2	23,5
04690	1/4"	20	14,3	29,5
04691	5/16"	21	15,5	26,5
04692	3/8"	24	18,4	31
04693	1/2"	29	22,9	34
06509	5/8"	32	25,9	32
04695	3/4"	36	29,7	36
04696	1"	43	36,5	44,5

BOCCOLA A PRESSARE PER TUBO SAE100 R2AT - EN 853 2SN NO SKIVE

DOUILLES POUR FLEXIBLE SAE100 R2AT - EN 853 2SN NO SKIVE
 FERRULE FOR HYDR. HOSE SAE100 R2AT - EN 853 2SN NO SKIVE
 SCHLAUCH HÜLSEN ZUM PRESSEN SAE100 R2AT - EN 853 2SN NO SKIVE
 CASQUILLAS PARA RACORES DE TUBO DE ALTA PRESIÓN SAE100 R2AT - EN 853 2SN NO SKIVE

TUBO SAE100 R2AT - EN 853 2SN

Art./Ref.	Ø interno inch/ Inside Ø inch	Ø esterno mm/ Outside Ø mm	Ø interno mm/ Inside Ø mm	Lunghezza mm/ Lenght mm
67576	3/16"	20	13,8	23,5
04710	1/4"	22	15,8	29,5
04711	5/16"	23	17	26,5
04712	3/8"	25,5	19,9	31
04693	1/2"	29	22,9	34
06509	5/8"	32	25,9	32
04695	3/4"	36	29,7	36
04716	1"	45	38,3	44,5
04554	1"1/4"	56	48,4	48
64836	1"1/2"	64	55,3	55

BOCCOLE UNIFICATE PER TUBO SAE100 R1AT/R2AT - EN853 1SN/2SN/2SC NO SKIVE

DOUILLES POUR FLEXIBLE SAE100 R1AT/R2AT - EN 853 1SN/2SN NO SKIVE
 UNIFIED FERRULE FOR HYDR. HOSE SAE100 R1AT/R2AT - EN853 1SN/2SN/2SC NO SKIVE
 SCHLAUCH HÜLSEN ZUM PRESSEN SAE100 R1AT/R2AT - EN 853 1SN/2SN NO SKIVE
 CASQUILLAS PARA RACORES DE TUBO DE ALTA PRESIÓN SAE100 R1AT/R2AT - EN 853 1SN/2SN NO SKIVE

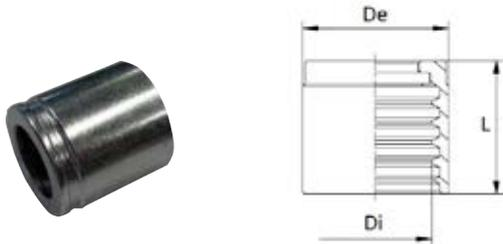

BOCCOLE UNIFICATE PER TUBO SAE100 R1AT/R2AT - EN853 1SN/2SN/2SC UNIFIED FERRULE FOR HYDR. HOSE SAE100 R1AT/R2AT - EN853 1SN/2SN/2SC

Art./Ref.	Ø interno inch/ Inside Ø inch	Ø esterno mm/ Outside Ø mm	Ø interno mm/ Inside Ø mm	Lunghezza mm/ Lenght mm
64841	1/4"	22,5	15,5	25,5
64842	5/16"	23,5	17	26,5
64843	3/8"	25	19,4	27
04693	1/2"	29	22,9	34
06509	5/8"	32	25,9	32
04695	3/4"	36	29,7	36

BOCCOLA A PRESSARE PER TUBO SAE 100 R7

DOUILLES POUR FLEXIBLE SAE100 R7
 FERRULE FOR HYDR. HOSE SAE100 R7
 SCHLAUCH HÜLSEN ZUM PRESSEN
 CASQUILLAS PARA RACORES DE TUBO DE ALTA PRESIÓN



**TUBO SAE100 R7
 HOSE SAE100 R7**

Art./Ref.	Ø interno inch/ Inside Ø inch	Ø esterno mm/ Outside Ø mm	Ø interno mm/ Inside Ø mm	Lunghezza mm/ Lenght mm
12282	3/16"	14	10,6	24
04771	1/4"	17	13,4	25,5
04772	5/16"	19	15,2	26,5
04773	3/8"	21	16,7	27

BOCCOLA A PRESSARE PER TUBO TERMOPLASTICO RINFORZATO

DOUILLES POUR FLEXIBLE THERMOPLASTIQUE RENFORCE'
 FERRULE FOR THERMOPLASTIC HOSE REINFORCED
 SCHLAUCH HÜLSEN ZUM PRESSEN
 CASQUILLAS PARA RACORES DE TUBO DE ALTA PRESIÓN TERMOPLÁSTICO

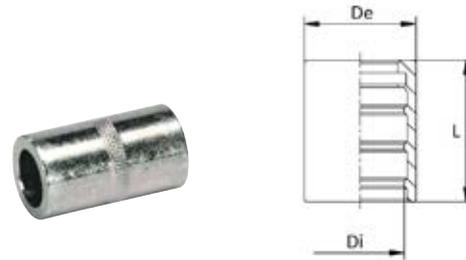

TUBO TERMOPLASTICO RINFORZATO

Art./Ref.	Ø interno inch/ Inside Ø inch	Ø esterno mm/ Outside Ø mm	Ø interno mm/ Inside Ø mm	Lunghezza mm/ Lenght mm
05017	1/4"	18	13	30
32954	5/16"	20	15,4	30
05018	3/8"	22	17	32

BOCCOLA A PRESSARE PER TUBO DA IDROPULITRICE

DOUILLE POUR LAVEUSES
 FERRULE FOR WASHING MACHINE
 SCHL. FÜR HOCHDRUCKREINIGER
 CASQUILLOS PARA MAGUINAS DE LAV.

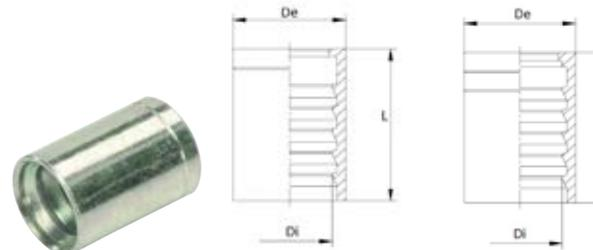

TUBO ALTA PRESSIONE PER IDROPULITRICI

Art./Ref.	Ø interno inch/ Inside Ø inch	Ø esterno mm/ Outside Ø mm	Ø interno mm/ Inside Ø mm	Lunghezza mm/ Lenght mm
04690	1/4"	20	14,3	29,5
04710	1/4"	22	15,8	29,5
04691	5/16"	21	15,5	26,5
04692	3/8"	24	18,4	31
04711	5/16"	23	17	26,5
04712	3/8"	25,5	19,9	31

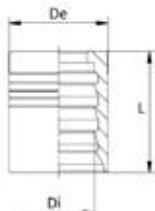
BOCCOLA A PRESSARE PER TUBO 4SP - 4SH
DOUILLES POUR FLEXIBLE EN 856 4SP-4SH
FERRULE FOR HYDR. HOSES 4SP - 4SH
SCHLAUCH HÜLSEN ZUM PRESSEN
CASQUILLAS PARA RACORES DE TUBO DE ALTA PRESIÓN

TUBO EN 856 4SP-4SH

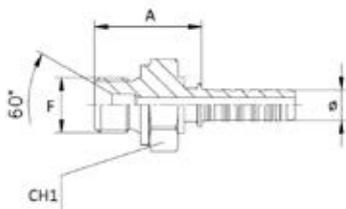
Art./Ref.	Ø interno inch/ Inside Ø inch	Ø esterno mm/ Outside Ø mm	Ø interno mm/ Inside Ø mm	Lunghezza mm/ Length mm	Tipo/ Type
02352	1/2"	29	21,6	35	4SP
16494	5/8"	33	25	38	4SP
02350	3/4"	38	29,2	43	4SH
02351	1"	45	36,2	58	4SH
02362	1"1/4"	52	43	64	4SH
64839	1"1/2"	60	50	72	4SH

RACCORDO FILETTATO MASCHIO A PRESSARE 60°
RACCORD FILETE MALE 60°
STRAIGHT MALE THREADED FITTING 60°
ARMATUR MIT AUSSENGEWINDE ZUM PRESSEN 60°
RACOR ROSCADO MACHO 60°

Art./Ref.	Ø interno inch/ Inside Ø inch	Ø interno mm/ Inside Ø mm	Filettatura esterna/ External Thread	A mm	CH1
67480	3/16"	5	1/8"	19	14
12283	3/16"	5	1/4"	22,5	19
04743	1/4"	6	1/4"	22,5	19
04744	1/4"	6	3/8"	25,5	22
04723	1/4"	6	1/2"	29	27
67481	5/16"	8	1/4"	23	19
04745	5/16"	8	3/8"	26	22
04746	5/16"	8	1/2"	29,5	27
04747	3/8"	10	3/8"	26	22
04748	3/8"	10	1/2"	29,5	27
04749	1/2"	13	3/8"	26	22
04750	1/2"	13	1/2"	29,5	27
16536	1/2"	13	3/4"	33	32
04731	5/8"	16	5/8"	32,5	30
16537	5/8"	16	3/4"	33,5	32
04751	3/4"	19	3/4"	34	32
16564	3/4"	19	1"	38,5	41
04752	1"	25	1"	39	41
67486	1"	25	1"1/4"	40	50
04756	1"1/4"	32	1"1/4"	45,5	50
04759	1"1/2"	40	1"1/2"	49,5	55
67488	2"	50	2"	58,5	70

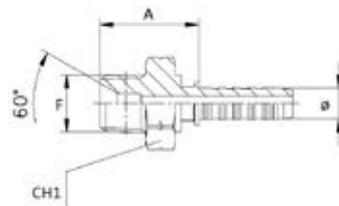
Art./Ref.	Ø interno inch/ Inside Ø inch	Ø interno mm/ Inside Ø mm	Filettatura esterna/ External Thread	A mm	CH1
67492	1/4"	6	10x1	22	15
67493	1/4"	6	12x1,5	24,5	17
04537	1/4"	6	14x1,5	24,5	19
04824	1/4"	6	16x1,5	26,5	22
16538	5/16"	8	16x1,5	27	22
67496	5/16"	8	18x1,5	27,5	24
67497	3/8"	10	14x1,5	25	19
04757	3/8"	10	16x1,5	27	22
04758	3/8"	10	18x1,5	27,5	24
04733	3/8"	10	20x1,5	31	27
04760	3/8"	10	22x1,5	31	27
04761	1/2"	13	18x1,5	27,5	24
04762	1/2"	13	20x1,5	31	27
04763	1/2"	13	22x1,5	31	27

RACCORDO FILETTATO MASCHIO A PRESSARE NPT
RACCORD FILETE MALE NPT
STRAIGHT MALE THREADED FITTING NPT
ARMATUR MIT AUSSENGEWINDE ZUM PRESSEN NPT
RACOR ROSCADO MACHO NPT

Art./Ref.	Ø interno inch/ Inside Ø inch	Ø interno mm/ Inside Ø mm	Filettatura esterna/ External Thread	A mm	CH1
16394	1/4"	6	1/4" NPT	25	14
16395	3/8"	10	3/8" NPT	25,5	17
16139	3/8"	10	1/2" NPT	31	22
16396	1/2"	13	1/2" NPT	31	22
16397	3/4"	19	3/4" NPT	34	27
16398	1"	25	1" NPT	41	36

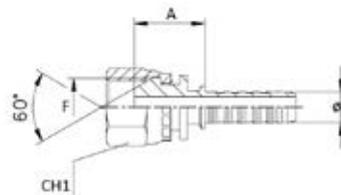
RACCORDO FILETTATO FEMMINA DIRITTO A PRESSARE 60°
RACCORD FILETE FEMELLE DROIT 60°
STRAIGHT FEMALE THREADED FITTING 60°
ARMATUR MIT ÜBERWURFMUTTER ZUM PRESSEN 60°
RACOR ROSCADO HEMBRA RECTO 60°

Art./Ref.	Ø interno inch/ Inside Ø inch	Ø interno mm/ Inside Ø mm	Filettatura interna/ Inner Thread	A mm	CH1
67455	3/16"	5	1/8"	15,5	14
12284	3/16"	5	1/4"	15,5	19
04720	1/4"	6	1/4"	15,5	19
04721	1/4"	6	3/8"	17,5	22
67457	1/4"	6	1/2"	19	27
16118	5/16"	8	1/4"	16	19
04722	5/16"	8	3/8"	18	22

Art./Ref.	Ø interno inch/ Inside Ø inch	Ø interno mm/ Inside Ø mm	Filettatura interna/ Inner Thread	A mm	CH1
16119	5/16"	8	1/2"	19	27
67458	3/8"	10	1/4"	16	19
04724	3/8"	10	3/8"	18	22
04725	3/8"	10	1/2"	19	27
04726	1/2"	13	3/8"	18	22
04727	1/2"	13	1/2"	19	27
67459	1/2"	13	5/8"	19,5	30
16539	1/2"	13	3/4"	21,5	32
67460	5/8"	16	1/2"	19	27
06510	5/8"	16	5/8"	20	30
16540	5/8"	16	3/4"	22	32
04728	3/4"	19	3/4"	22,5	32
16566	3/4"	19	1"	23,5	38
04729	1"	25	1"	24	38
02405	1"1/4"	32	1"1/4"	34	50
04730	1"1/2"	40	1"1/2"	37	55
67471	1/4"	6	12x1,5	15,5	17
04826	1/4"	6	14x1,5	15,5	19
04827	1/4"	6	16x1,5	17,5	22
67473	5/16"	8	14x1,5	16	19
14768	5/16"	8	16x1,5	18	22
16120	5/16"	8	18x1,5	18	22
04734	3/8"	10	16x1,5	18	22
04735	3/8"	10	18x1,5	18	22
04736	3/8"	10	20x1,5	19	27
04737	3/8"	10	22x1,5	19	27
04738	1/2"	13	18x1,5	18	22
04739	1/2"	13	20x1,5	19	27
04740	1/2"	13	22x1,5	19	27
67478	5/8"	16	26x1,5	22	32
67479	3/4"	19	26x1,5	22,5	32

Art./Ref.	Ø interno inch/ Inside Ø inch	Ø interno mm/ Inside Ø mm	Filettatura interna/ Inner Thread	A mm	B mm	CH1
05036	3/8"	10	18x1,5	19	51,5	22
67525	3/8"	10	20x1,5	21	53,5	27
67526	3/8"	10	22x1,5	21	53,5	27

RACCORDO FEMMINA CURVO 90° A PRESSARE (60°)

RACCORD FILETE FEMELLE COURBE A 90° (60°)

FEMALE FITTING 90° TO BE PRESSED (60°)

90° ARMATUR MIT ÜBERWURFMUTTER ZUM PRESSEN (60°)

RACOR HEMBRA CURVO (60°)

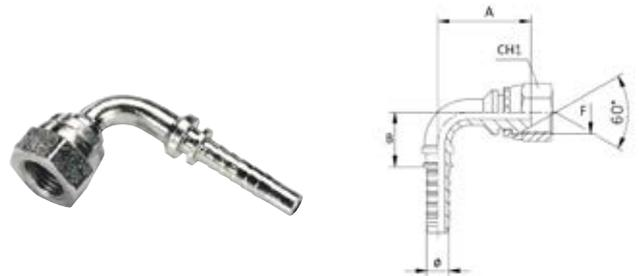

Art./Ref.	Ø interno inch/ Inside Ø inch	Ø interno mm/ Inside Ø mm	Filettatura interna/ Inner Thread	A mm	B mm	CH1
12285	3/16"	5	1/4"	26	21	19
04775	1/4"	6	1/4"	26,5	21	19
04776	1/4"	6	3/8"	30,5	21	22
16121	5/16"	8	1/4"	32	25,5	19
04777	5/16"	8	3/8"	35	25,5	22
67534	3/8"	10	1/4"	34,5	29	19
04779	3/8"	10	3/8"	36,5	29	22
04780	3/8"	10	1/2"	39,5	29	27
04781	1/2"	13	3/8"	40,5	35,5	22
04782	1/2"	13	1/2"	41,5	35,5	27
67535	1/2"	13	5/8"	43	35,5	30
16541	1/2"	13	3/4"	47,5	35,5	32
04778	5/8"	16	5/8"	45	39,5	30
16542	5/8"	16	3/4"	49	39,5	32
04783	3/4"	19	3/4"	58	46,5	32
16590	3/4"	19	1"	61,5	46,5	41
04784	1"	25	1"	62	63	41
67536	1"	25	1"1/4"	72,5	63	50
02404	1"1/4"	32	1"1/4"	83	75,5	50
67537	1"1/4"	32	1"1/2"	88,5	75,5	55
02406	1"1/2"	40	1"1/2"	99	100,5	55
67544	1/4"	6	12x1,5	26,5	21	17
04825	1/4"	6	14x1,5	26,5	21	19
04534	1/4"	6	16x1,5	30,5	21	22
67545	5/16"	8	14x1,5	32	25,5	19
67546	5/16"	8	16x1,5	35	25,5	22
16123	5/16"	8	18x1,5	35	25,5	22
04789	3/8"	10	16x1,5	36,5	29	22
04790	3/8"	10	18x1,5	36,5	29	22
04791	3/8"	10	20x1,5	39,5	29	27
04792	3/8"	10	22x1,5	-	-	27
04793	1/2"	13	18x1,5	40,5	35,5	22
04794	1/2"	13	20x1,5	41,5	35,5	27
04795	1/2"	13	22x1,5	41,5	35,5	27
67548	1/2"	13	26x1,5	47,5	35,5	32
67551	3/4"	19	26x1,5	58	46,5	32

RACCORDO FEMMINA CURVO 45° A PRESSARE (60°)

RACCORD FILETE FEMELLE COURBE A 45° (60°)

FEMALE FITTING 45° TO BE PRESSED (60°)

45° ARMATUR MIT ÜBERWURFMUTTER ZUM PRESSEN (60°)

RACOR HEMBRA CURVO (60°)

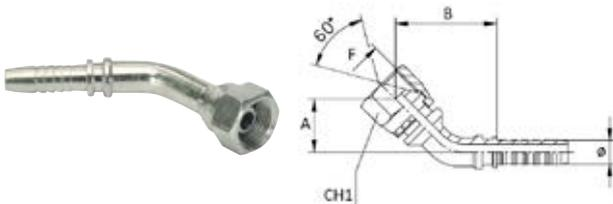

Art./Ref.	Ø interno inch/ Inside Ø inch	Ø interno mm/ Inside Ø mm	Filettatura interna/ Inner Thread	A mm	B mm	CH1
05030	1/4"	6	1/4"	14	37,5	19
05024	1/4"	6	3/8"	17,5	40,5	22
05031	3/8"	10	3/8"	19	51,5	22
05026	3/8"	10	1/2"	21	53,5	27
05027	1/2"	13	3/8"	20,5	60,5	22
05032	1/2"	13	1/2"	21	61	27
67508	1/2"	13	5/8"	22	62,5	28
16543	5/8"	16	3/4"	25	69	32
05029	3/4"	19	3/4"	28	80,5	32
67510	3/4"	19	1"	31	83,5	38
67511	1"	25	1"	29	99,5	38

RACCORDO CON ESTREMITA' TUBOLARE DIRITTA

RACCORD AVEC EXTREMITE' DROITE
STRAIGHT SMOOTH END FITTING
GLATTER GERADER ROHRSTUTZEN
RACOR CON EXTREMO TUBULAR RECTO

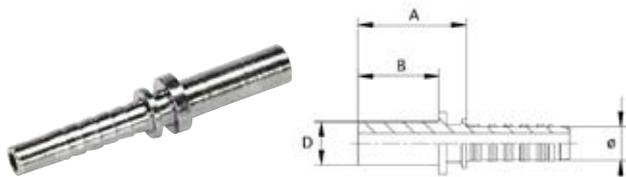

Art./Ref.	D mm	Ø interno inch/ Inside Ø inch	Ø interno mm/ Inside Ø mm	A mm	B mm
67740	6	1/4"	6	24,5	19
04536	8	1/4"	6	28	22,5
02409	10	1/4"	6	27	21,5
67741	12	1/4"	6	31	25,5
67742	8	5/16"	8	26	21
56333	10	5/16"	8	27,5	21,5
16126	12	5/16"	8	31,5	25,5
04539	10	3/8"	10	27,5	21,5
04766	12	3/8"	10	31,5	25,5
04767	14	3/8"	10	29,5	23,5
04719	15	3/8"	10	29	23
67743	12	1/2"	13	31,5	25,5
04768	14	1/2"	13	29,5	23,5
02410	15	1/2"	13	29	23
04769	16	1/2"	13	30	24
67747	22	3/4"	19	29,5	22,5
67748	28	1"	25	32	24

RACCORDO CON ESTREMITA' TUBOLARE CURVA 90°

RACCORD COURBE 90°
90° SMOOTH FITTING
90° GLATTER ROHRSTUTZEN
RACOR CON EXTREMO TUBULAR CURVO A 90°



Art./Ref.	D mm	Ø interno inch/ Inside Ø inch	Ø interno mm/ Inside Ø mm	A mm	B mm	C mm
67769	6	3/16"	5	37	21,5	19
67770	6	1/4"	6	37	21,5	19
04541	8	1/4"	6	38,5	21,5	22,5
02482	10	1/4"	6	37,5	21,5	21,5
04538	10	3/8"	10	46,5	29,5	21,5
04820	12	3/8"	10	50,5	29,5	25,5
04821	14	3/8"	10	48,5	29,5	23,5
02486	15	1/2"	13	52	36	23
04822	16	1/2"	13	53	36	24

RACCORDO AD OCCHIO A PRESSARE PER BOCCHETTONI

RACCORD AVEC BANJO
EYE FITTING (TO BE PRESSED)
ARMATUR MIT RINGSTUTZEN ZUM PRESSEN
RACOR AD OCCHIO OJO (A PRESIÓN)

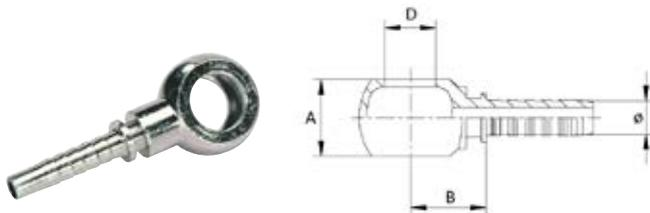

Art./Ref.	D mm	Ø interno inch/ Inside Ø inch	Ø interno mm/ Inside Ø mm	A mm	B mm
67777	1/8"	3/16"	5	10	20
36440	1/4"	3/16"	5	14	23
04798	1/4"	1/4"	6	14	23
04799	3/8"	1/4"	6	17	25
16124	1/4"	5/16"	8	14	26,5
04800	3/8"	5/16"	8	17	26
16138	1/2"	5/16"	8	22	28
67779	1/4"	3/8"	10	14	26,5
04802	3/8"	3/8"	10	17	25,5
04803	1/2"	3/8"	10	22	28
04804	3/8"	1/2"	13	17	28,5
04805	1/2"	1/2"	13	22	28
75403	3/4"	1/2"	13	30	28,5
67780	3/4"	5/8"	16	30	37,5
04806	3/4"	3/4"	19	30	38
16544	1"	1"	25	37,5	49,5
67782	10x1	1/4"	6	10	22
12291	12x1,5	1/4"	6	12	25
04535	14x1,5	1/4"	6	14	23
67783	16x1,5	1/4"	6	16	25
67785	14x1,5	5/16"	8	14	26,5
04810	16x1,5	5/16"	8	16	25,5
67786	18x1,5	5/16"	8	20	27,5
67787	14x1,5	3/8"	10	14	26,5
04812	16x1,5	3/8"	10	16	28,5
04813	18x1,5	3/8"	10	20	27,5
67788	22x1,5	3/8"	10	22	28
04815	18x1,5	1/2"	13	20	30,5
04816	20x1,5	1/2"	13	22	28
04817	22x1,5	1/2"	13	22	28

RACCORDO MASCHIO JIC 74°

RACCORD MALE JIC 74°
 MALE FITTING JIC 74°
 SCHLAUCHARMATUR STECKER JIC 74°
 RACOR MACHO JIC 74°

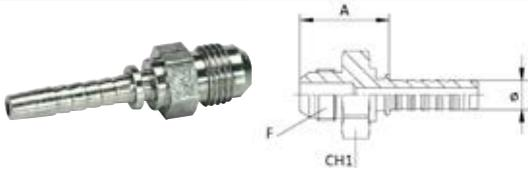

Art./Ref.	Ø interno inch/ Inside Ø inch	Ø interno mm/ Inside Ø mm	Filettatura esterna/ External Thread	A mm	CH1
67637	3/16"	5	1/2"-20	26,5	12
19508	1/4"	6	7/16"-20	26,5	12
67638	1/4"	6	1/2"-20	26,5	14
02344	1/4"	6	9/16"-18	27,5	17
67640	5/16"	8	9/16"-18	28	17
02357	3/8"	10	9/16"-18	28	17
02355	3/8"	10	3/4"-16	30,5	22
67641	3/8"	10	7/8"-16	34,5	24
02356	1/2"	13	3/4"-16	30,5	22
02353	1/2"	13	7/8"-14	34,5	24
67642	1/2"	13	1"1/16"-12	39	30
67643	5/8"	16	7/8"-16	35	24
67644	5/8"	16	1"1/16"-12	39,5	30
04588	3/4"	19	1"1/16"-12	40	30
67645	3/4"	19	1"3/16"-12	40,5	32
04585	3/4"	19	1"5/16"-12	41	36
04586	1"	25	1"5/16"-12	41	36

RACCORDO FEMMINA DIRITTO JIC 74°

RACCORD FEMELLE JIC 74° DROIT
 STRAIGHT FEMALE FITTING JIC 74°
 ARMATUR MIT ÜBERWURFMUTTER JIC 74°
 RACOR HEMBRA RECTO JIC 74°



Art./Ref.	Ø interno inch/ Inside Ø inch	Ø interno mm/ Inside Ø mm	Filettatura interna/ Inner Thread	A mm	CH1
67619	3/16"	5	7/16"-20	13,5	14
19507	1/4"	6	7/16"-20	13,5	14
67621	1/4"	6	1/2"-20	13,5	17
05251	1/4"	6	9/16"-18	13,5	19
16125	5/16"	8	9/16"-18	14	19
05254	3/8"	10	9/16"-18	14	19
05255	3/8"	10	5/8"-18	15	22
05256	3/8"	10	3/4"-16	17	24
67623	3/8"	10	7/8"-16	17	27
05258	1/2"	13	3/4"-16	17	24
05259	1/2"	13	7/8"-14	17	27
67624	1/2"	13	1"1/16"-12	19,5	32
67625	5/8"	16	7/8"-16	17,5	27
67626	5/8"	16	1"1/16"-12	20	32
05260	3/4"	19	1"1/16"-12	20,5	32
67628	3/4"	19	1"3/16"-12	20,5	36
05262	3/4"	19	1"5/16"-12	21,5	41
05264	1"	25	1"5/16"-12	22	41

RACCORDO FEMMINA CURVO 45° JIC 74°

RACCORD FEMELLE COURBE A 45° JIC 74°
 FEMAL FITTING 45° JIC 74°
 45° ARMATUR MIT ÜBERWURFMUTTER JIC 74°
 RACOR HEMBRA CURVO A 45° JIC 74°

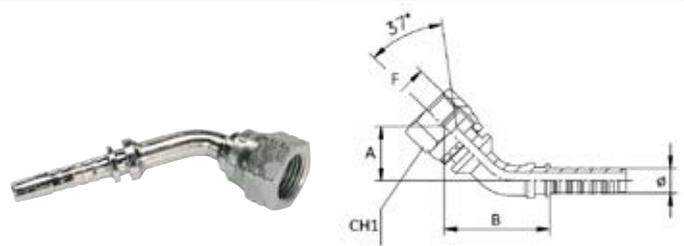

Art./Ref.	Ø interno inch/ Inside Ø inch	Ø interno mm/ Inside Ø mm	Filettatura interna/ Inner Thread	A mm	B mm	CH1
67650	3/16"	5	7/16"-20	13	37	14
67652	1/4"	6	7/16"-20	13	37	14
07825	1/4"	6	1/2"-20	13	37	17
07826	1/4"	6	9/16"-18	13,5	37,5	19
07827	3/8"	10	9/16"-18	18	50	19
67655	3/8"	10	7/8"-16	21	53,5	27
67656	1/2"	13	3/4"-16	20	60	24
07829	1/2"	13	7/8"-14	20,5	60,5	27
67657	5/8"	16	7/8"-14	21	65,5	27
07823	3/4"	19	1"1/16"-12	27,5	80,5	32

RACCORDO FEMMINA CURVO 90° JIC 74°

RACCORD FEMELLE COURBE A 90° JIC 74°
 FEMAL FITTING 90° JIC 74°
 90° ARMATUR MIT ÜBERWURFMUTTER JIC 74°
 RACOR HEMBRA CURVO 90° JIC 74°

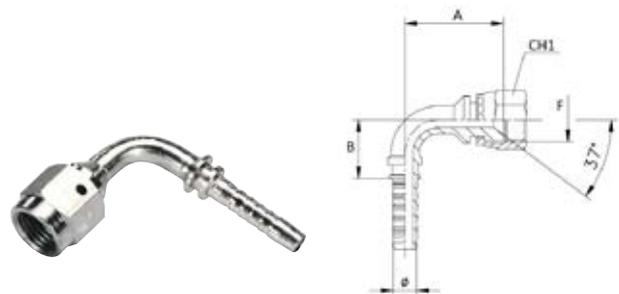

Art./Ref.	Ø interno inch/ Inside Ø inch	Ø interno mm/ Inside Ø mm	Filettatura interna/ Inner Thread	A mm	B mm	CH1
19442	1/4"	6	7/16"-20	24,5	21,5	14
67668	1/4"	6	1/2"-20	24,5	21,5	17
05268	1/4"	6	9/16"-18	25,5	21,5	19
16127	5/16"	8	9/16"-18	30,5	26	19
05270	3/8"	10	9/16"-18	34,5	29,5	19
05272	3/8"	10	3/4"-16	38	29,5	24
67670	3/8"	10	7/8"-14	39	29,5	27
05274	1/2"	13	3/4"-16	39,5	36	24
05275	1/2"	13	7/8"-14	40,5	36	27
67671	5/8"	16	7/8"-14	43,5	40	27
67672	5/8"	16	1"1/16"-12	48	40	32
67673	3/4"	19	7/8"-14	43,5	40	27
05276	3/4"	19	1"1/16"-12	57	47	32
67674	3/4"	19	1"3/16"-12	61	47	36
05278	3/4"	19	1"5/16"-12	61	47	41
05279	1"	25	1"5/16"-12	62	63	41

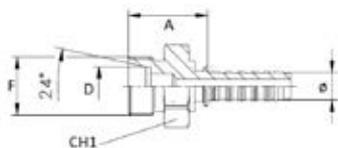
RACCORDO FILETTATO METRICO DIN 24° MASCHIO
RACCORD MALE METRIQUE 24°
MALE METRIC FITTING DIN NORM 24°
SCHLAUCHFASSUNG, METRISCHE GEWINDE, STECKER, NACH DIN NORM 24°
RACOR MACHO ROSCA METRICA DIN 24°

Art./Ref.	Ø interno inch/ Inside Ø inch	Ø interno mm/ Inside Ø mm	Filettatura esterna/ External Thread	A mm	CH1	D mm
67568	1/4"	6	12x1,5	19,5	12	6L
04581	1/4"	6	14x1,5	23,5	14	8L
04880	1/4"	6	16x1,5	21,5	17	10L
02354	1/4"	6	18x1,5	22,5	19	12L
67569	1/4"	6	20x1,5	27,5	22	12S
67570	5/16"	8	16x1,5	22	17	10L
67571	5/16"	8	18x1,5	23	19	12L
67572	5/16"	8	20x1,5	28	22	12S
67573	3/8"	10	16x1,5	22	17	10L
04882	3/8"	10	18x1,5	23	19	12L
67574	3/8"	10	20x1,5	28	22	12S
67575	3/8"	10	22x1,5	24	24	15L
04884	1/2"	13	22x1,5	24	24	15L
04885	1/2"	13	24x1,5	30	27	16S
67577	1/2"	13	26x1,5	25	27	18L
67583	3/4"	19	30x2	35	32	20S

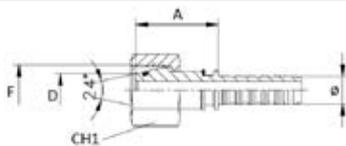
RACCORDO FILETTATO METRICO DIN 24° FEMMINA
RACCORD FEMELLE METRIQUE 24°
FEMALE METRIC FITTING DIN NORM 24°
SCHLAUCHFASSUNG, METRISCHE GEWINDE, MUFFE, NACH DIN NORM 24°
RACOR HEMBRA METRICA DIN 24°

Art./Ref.	Ø interno inch/ Inside Ø inch	Ø interno mm/ Inside Ø mm	Filettatura interna/ Inner Thread	A mm	CH1	D mm
04587	1/4"	6	14x1,5	23,5	17	8L
04888	1/4"	6	16x1,5	25	19	10L
67876	1/4"	6	18x1,5	25	22	10S
04582	1/4"	6	18x1,5	25	22	12L
16128	5/16"	8	16x1,5	25,5	22	10L
16129	5/16"	8	18x1,5	25,5	22	12L
16130	5/16"	8	20x1,5	25,5	24	12S
67553	3/8"	10	16x1,5	25,5	19	10L
04890	3/8"	10	18x1,5	25,5	22	12L
58287	3/8"	10	20x1,5	25,5	24	12S
67554	3/8"	10	22x1,5	26	27	15L
04892	1/2"	13	22x1,5	26	27	15L
04893	1/2"	13	24x1,5	29,5	30	16S
67555	1/2"	13	26x1,5	27	32	18L
67556	5/8"	16	26x1,5	27,5	32	18L
67557	5/8"	16	30x2	34,5	36	20S
67558	3/4"	19	30x2	29,5	36	22L
67559	3/4"	19	30x2	35	36	20S

Art./Ref.	Ø interno inch/ Inside Ø inch	Ø interno mm/ Inside Ø mm	Filettatura interna/ Inner Thread	A mm	CH1	D mm
67560	3/4"	19	36x2	35	41	25S
67562	1"	25	42x2	40,5	50	30S

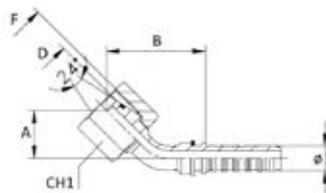
RACCORDO FILETTATO FEMMINA 45° DIN 24°
RACCORD COUDE METRIQUE 24° FEMELLE 45°
45° FEMALE METRIC FITTING DIN 24°
MUFFE NACH DIN NORM 24°
RACOR HEMBRA ROSCA CON CURVA 45°

Art./Ref.	Ø interno inch/ Inside Ø inch	Ø interno mm/ Inside Ø mm	Filettatura interna/ Inner Thread	A mm	B mm	CH1	D mm
67592	1/4"	6	16x1,5	17	46,5	19	8S
67596	3/8"	10	18x1,5	18,5	54	22	12L
67599	1/2"	13	22x1,5	20,5	60	27	15L
67600	1/2"	13	24x1,5	21,5	61,5	30	16S
67602	5/8"	16	26x1,5	22,5	67	32	18L
67603	5/8"	16	30x2	25,5	70	36	20S
67604	3/4"	19	30x2	27	81	36	22L
75938	3/4"	19	30x2	28,5	82,5	36	20S

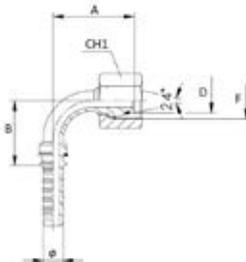
RACCORDO FILETTATO METRICO DIN 24° FEMMINA CURVO 90°
RACCORD COUDE METRIQUE 24°, FEMELLE 90°
90° FEMALE METRIC FITTING DIN NORM 24°
90° SCHLAUCHFASSUNG METRISCHE GEWINDE, MUFFE, NACH DIN NORM 24°
RACOR HEMBRA ROSCA CON CURVA 90°

Art./Ref.	Ø interno inch/ Inside Ø inch	Ø interno mm/ Inside Ø mm	Filettatura interna/ Inner Thread	A mm	B mm	CH1	D mm
04583	1/4"	6	14x1,5	33	26	17	8L
04896	1/4"	6	16x1,5	34,5	26	19	10L
04580	1/4"	6	18x1,5	35	26	22	12L
16131	5/16"	8	16x1,5	32,5	29	19	10L
16132	5/16"	8	18x1,5	35,5	27,5	24	12S
04898	3/8"	10	18x1,5	37	32	22	12L
58288	3/8"	10	20x1,5	37	32	24	12S
67610	3/8"	10	22x1,5	40,5	32	27	15L
04900	1/2"	13	22x1,5	41	35,5	27	15L
04901	1/2"	13	24x1,5	42,5	35,5	30	16S
67611	5/8"	16	26x1,5	45,5	40	32	18L
67612	5/8"	16	30x2	49,5	40	36	20S
67613	3/4"	19	30x2	56,5	47,5	36	22L
75937	3/4"	19	30x2	58,5	47,5	36	20S

RACCORDO FILETTATO MASCHIO A PRESSARE "ORFS"

RACCORD FILETE MALE "ORFS"
 STRAIGHT MALE THREADED FITTING "ORFS"
 ARMATUR MIT AUSSENGEWINDE ZUM PRESSEN "ORFS"
 RACOR ROSCADO MACHO "ORFS"

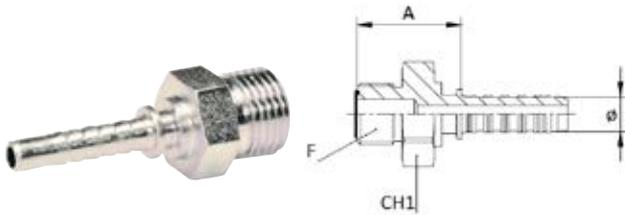

Art./Ref.	Ø interno inch/ Inside Ø inch	Ø interno mm/ Inside Ø mm	Filettatura esterna/ External Thread	A mm	CH1
37130	1/4"	6	9/16"-18	24,5	17
37133	3/8"	10	11/16"-16	27,5	19
37134	3/8"	10	13/16"-16	30	22
37135	1/2"	13	13/16"-16	30	22
37136	1/2"	13	1"-14	34,5	27
37137	1/2"	13	1"3/16"-12	37,5	32
57897	3/4"	19	1"7/16"-12	40,5	41
57899	1"1/4"	32	1"11/16"-12	45	46
57900	1"1/2"	40	2"-12	47,5	55

RACCORDO FILETTATO FEMMINA DIRITTO A PRESSARE "ORFS"

RACCORD FILETE FEMELLE DROIT "ORFS"
 STRAIGHT FEMALE THREADED FITTING "ORFS"
 ARMATUR MIT ÜBERWURFMUTTER ZUM PRESSEN "ORFS"
 RACOR ROSCADO HEMBRA RECTO "ORFS"

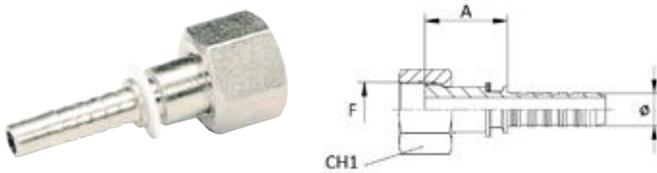

Art./Ref.	Ø interno inch/ Inside Ø inch	Ø interno mm/ Inside Ø mm	Filettatura interna/ Inner Thread	A mm	CH1
37138	1/4"	6	9/16"-18	21	17
37139	1/4"	6	11/16"-16	23	22
37140	5/16"	8	11/16"-16	23,5	22
37141	3/8"	10	11/16"-16	23,5	22
37142	3/8"	10	13/16"-16	26,5	24
37143	1/2"	13	13/16"-16	26,5	24
37144	1/2"	13	1"-14	31	30
37145	1/2"	13	1"3/16"-12	33	36
67684	5/8"	16	1"-14	31	30
67685	5/8"	16	1"3/16"-12	33,5	36
57901	3/4"	19	1"3/16"-12	34	36
57902	3/4"	19	1"7/16"-12	35	41
57903	1"	25	1"7/16"-12	35,5	46
57904	1"1/4"	32	1"11/16"-1	36,5	50
57905	1"1/2"	40	2"-12	37,5	60

RACCORDO FEMMINA CURVO 90° A PRESSARE "ORFS"

RACCORD FILETE FEMELLE COURBE A 90° "ORFS"
 FEMALE FITTING 90° (TO BE PRESSED) "ORFS"
 90° ARMATUR MIT ÜBERWURFMUTTER ZUM PRESSEN "ORFS"
 RACOR HEMBRA CURVO "ORFS"



Art./Ref.	Ø interno inch/ Inside Ø inch	Ø interno mm/ Inside Ø mm	Filettatura interna/ Inner Thread	A mm	B mm	CH1
37146	1/4"	6	9/16"-18	26,5	26	17
37147	1/4"	6	11/16"-16	29,5	26	22
37148	5/16"	8	11/16"-16	30	27,5	22
37149	3/8"	10	11/16"-16	31,5	32	22
37150	3/8"	10	13/16"-16	34,5	32	24
37151	1/2"	13	13/16"-16	35	35,5	24
37152	1/2"	13	1"-14	39	35,5	30
37153	1/2"	13	1"3/16"-12	42	35,5	36
67717	5/8"	16	1"-14	41	40	30
67718	5/8"	16	1"3/16"-12	44	40	36
57906	3/4"	19	1"3/16"-12	53	47,5	36
57907	3/4"	19	1"7/16"-12	56,5	47,5	41
57908	1"	25	1"7/16"-12	57,5	63	46
57909	1"1/4"	32	1"11/16"-1	72	75,5	50
57910	1"1/2"	40	2"-12	87	101	60

RACCORDO FLANGIA DIRITTO SAE 3000

RACCORD FLASQUE DROIT SAE 3000
 FLANGE STRAIGHT FITTING SAE 3000
 FLANSCH ANSCHLUSS GERADE SAE 3000
 RACOR ARANDELA RECTA SAE 3000

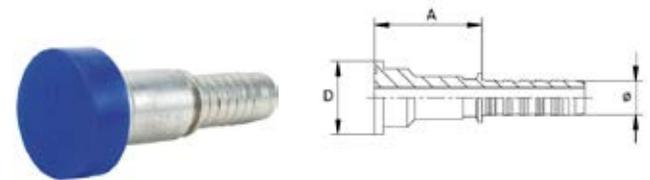

Art./Ref.	D mm	Tipo/Type	Ø interno inch/ Inside Ø inch	Ø interno mm/ Inside Ø mm	A mm
64879	38	3/4"	3/4"	19	50
64880	44,5	1"	3/4"	19	53
64881	44,5	1"	1"	25	53,5
64882	50,8	1"1/4"	1"	25	58
64883	50,8	1"1/4"	1"1/4"	32	59

RACCORDO FLANGIA 45° SAE 3000

RACCORD FLASQUE 45° SAE 3000
 FLANGE 45° FITTING SAE 3000
 FLANSCH ANSCHLUSS 45° SAE 3000
 RACOR ARANDELA 45° SAE 3000

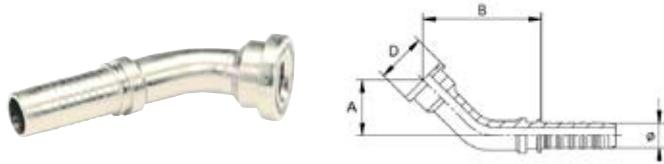

Art./Ref.	D mm	Tipo/Type	Ø interno inch/ Inside Ø inch	Ø interno mm/ Inside Ø mm	A mm	B mm
67444	38	3/4"	3/4"	19	27,5	47
67445	44,5	1"	1"	25	28	63
67446	50,8	1"1/4"	1"	25	30	63
67447	50,8	1"1/4"	1"1/4"	32	33	75,5

RACCORDO FLANGIA 90° SAE 3000

RACCORD FLASQUE 90° SAE 3000
 FLANGE 90° FITTING SAE 3000
 FLANSCH ANSCHLUSS 90° SAE 3000
 RACOR ARANDELA 90° SAE 3000



Art./Ref.	D mm	Tipo/Type	Ø interno inch/ Inside Ø inch	Ø interno mm/ Inside Ø mm	A mm	B mm
64892	38	3/4"	3/4"	19	57	47
64893	44,5	1"	3/4"	19	60	47
64894	44,5	1"	1"	25	61	63
64895	50,8	1"1/4"	1"	25	63,5	63
64896	50,8	1"1/4"	1"1/4"	32	74,5	75,5

SEMIFLANGE SAE 3000

SEMI FLASQUE SAE 3000
 HALF FLANGE SAE 3000
 HALB FLANSCH SAE 3000
 SEMI ARANDELAS SAE 3000

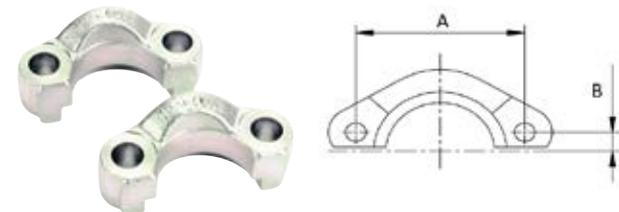

Art./Ref.	Tipo/Type	A mm	B mm
64869	3/4"	47,6	11,1
64870	1"	52,4	13,1
64871	1"1/4"	58,7	15,1
64872	1"1/2"	69,9	17,8

RACCORDO FLANGIA DIRITTA SAE 6000

RACCORD FLASQUE DROIT SAE 6000
 FLANGE STRAIGHT FITTING SAE 6000
 FLANSCH-ANSCHLÜSS GERADE SAE 6000
 RACOR ARANDELA RECTA SAE 6000

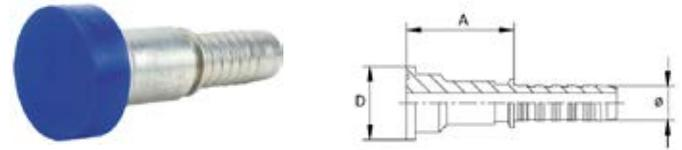

Art./Ref.	D mm	Tipo/Type	Ø interno inch/ Inside Ø inch	Ø interno mm/ Inside Ø mm	A mm
37154	41,3	3/4"	3/4"	19	50
37155	47,6	1"	3/4"	19	53
37156	47,6	1"	1"	25	53,5
37157	54	1"1/4"	1"	25	58

RACCORDO FLANGIA 45° SAE 6000

RACCORD FLASQUE 45° SAE 6000
 FLANGE 45° FITTING SAE 6000
 FLANSCH-ANSCHLÜSS 45° SAE 6000
 RACOR ARANDELA 45° SAE 6000

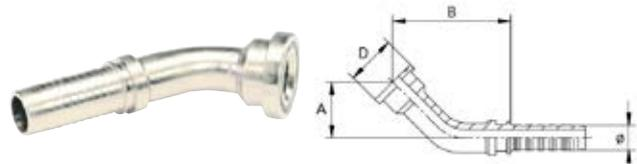

Art./Ref.	D mm	Tipo/Type	Ø interno inch/ Inside Ø inch	Ø interno mm/ Inside Ø mm	A mm	B mm
37164	41,3	3/4"	3/4"	19	30,5	84,5
37165	47,6	1"	3/4"	19	34,5	88,5
37166	47,6	1"	1"	25	33	106
37167	54	1"1/4"	1"	25	38	111
37168	54	1"1/4"	1"1/4"	32	41	128

RACCORDO FLANGIA 90° SAE 6000

RACCORD FLASQUE 90° SAE 6000
 FLANGE 90° FITTING SAE 6000
 FLANSCH-ANSCHLÜSS 90° SAE 6000
 RACOR ARANDELA 90° SAE 6000



Art./Ref.	D mm	Tipo/Type	Ø interno inch/ Inside Ø inch	Ø interno mm/ Inside Ø mm	A mm	B mm
37159	41,3	3/4"	3/4"	19	61	47
37160	47,6	1"	3/4"	19	67	47
37161	47,6	1"	1"	25	68	63
37162	54	1"1/4"	1"	25	75	63
37163	54	1"1/4"	1"1/4"	32	86	75,5

SEMI FLANGE SAE 6000

SEMI-FLASQUE SAE 6000
 HALF FLANGE SAE 6000
 HALB-FLANSCH SAE 6000
 SEMI ARANDELAS SAE 6000

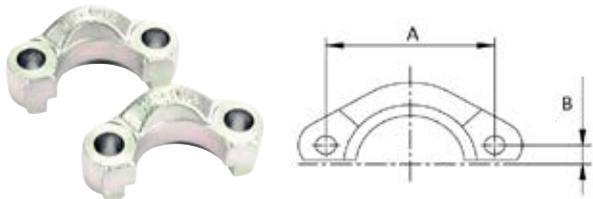

Art./Ref.	Tipo/Type	A mm	B mm
37169	3/4"	50,8	11,9
37170	1"	57,2	13,9
37171	1"1/4"	66,7	15,9

BOCCOLE PER RACCORDI RECUPERABILI TUBO SAE100 R2A - EN 853 2ST

DOUILLES POUR RACCORDS RECUPERABLES
 BUSHINGS FOR REUSABLE FITTING
 FUER WIEDERVERWENDBARE HÜLSEN SCHLAUCHARMATUR
 CASQUILLOS PARA RACORES RECUPERABLES



TUBO SAE100 R2A - EN 853 2ST

Art./Ref.	Ø interno inch/ Inside Ø inch	CH1	Lunghezza mm/ Lenght mm
06605	1/4"	19	35
06607	3/8"	24	42
06608	1/2"	27	49

BOCCOLE PER RACCORDI RECUPERABILI TUBO SAE100 R1T - EN 853 1SN

DOUILLES POUR RACCORDS RECUPERABLES
 BUSHINGS FOR REUSABLE FITTING
 FUER WIEDERVERWENDBARE HÜLSEN SCHLAUCHARMATUR
 CASQUILLOS PARA RACORES RECUPERABLES



TUBO SAE 100 R1AT - EN 853 1SN

Art./Ref.	Ø interno inch/ Inside Ø inch	CH1	Lunghezza mm/ Lenght mm
06670	1/4"	19	35
06671	3/8"	22	42
06672	1/2"	27	49

BOCCOLE PER RACCORDI RECUPERABILI TUBO SAE100 R2T - EN 853 2SN

DOUILLES POUR RACCORDS RECUPERABLES
 BUSHINGS FOR REUSABLE FITTING
 FUER WIEDERVERWENDBARE HÜLSEN SCHLAUCHARMATUR
 CASQUILLOS PARA RACORES RECUPERABLES



TUBO SAE 100 R2AT - EN 853 2SN

Art./Ref.	Ø interno inch/ Inside Ø inch	CH1	Lunghezza mm/ Lenght mm
06673	1/4"	19	39
06675	3/8"	24	45
06676	1/2"	27	53
06677	3/4"	36	55

BOCCOLE PER RACCORDI RECUPERABILI TUBO SAE100 R7

DOUILLES POUR RACCORDS RECUPERABLES
 BUSHINGS FOR REUSABLE FITTING
 FUER WIEDERVERWENDBARE HÜLSEN SCHLAUCHARMATUR
 CASQUILLOS PARA RACORES RECUPERABLES



TUBO SAE 100 R7

FLEXIBLE SAE100 R7HOSE SAE100 R7HYDR.SCHL.SAE100 R7MANGUERA SAE100 R7

Art./Ref.	Ø interno inch/ Inside Ø inch	CH1	Lunghezza mm/ Lenght mm
02481	1/4"	17	34

INSERTO RECUPERABILE MASCHIO

RACCORD RÉCUPERABLE MALE
 REUSABLE MALE FITTING
 WIEDERVERWENDBARE SCHLAUCHARMATUR STECKER
 RACOR RECUPERABLE MACHO



Art./Ref.	Ø interno inch/Inside Ø inch	Ø interno mm/Inside Ø mm	Filettatura esterna/External Thread	CH1	Lunghezza mm/Lenght mm
06624	1/4"	6	1/4"	19	55
06625	3/8"	10	3/8"	22	66
02386	3/8"	10	1/2"	27	68
06626	1/2"	13	1/2"	27	76

INSERTO RECUPERABILE FEMMINA DIRITTA

RACCORD RECUPERABLE FEMELLE DROIT
 REUSABLE STREIGHT FEMALE FITTING
 WIEDERVERWENDBARE SCHLAUCHARMATUR MUFFE
 RACOR RECUPERABLE HEMBRA RECTO



Art./Ref.	Ø interno inch/ Inside Ø inch	Ø interno mm/ Inside Ø mm	Filettatura interna/ Inner Thread	CH1	CH2
06610	1/4"	6	1/4"	19	17
06612	3/8"	10	3/8"	22	22
06613	3/8"	10	1/2"	27	27
06614	1/2"	13	1/2"	27	27
06615	3/4"	19	3/4"	32	32
06616	3/8"	10	18x1,5	22	22
06617	1/2"	13	22x1,5	27	27

INSERTO RECUPERABILE FEMMINA 90°

RACCORD RECUPERABLE FEMELLE 90°
 90° REUSABLE FEMALE FITTING
 WIEDERVERWENDBARE ARMATUR MUFFE 90°
 RACOR RECUPERABLE HEMBRA 90°



Art./Ref.	Ø interno inch/ Inside Ø inch	Ø interno mm/ Inside Ø mm	Filettatura interna/Inner Thread	CH1	CH2	Lunghezza mm/ Lenght mm
06618	1/4"	6	1/4"	19	12	59
06620	3/8"	10	3/8"	22	15	72
06621	1/2"	13	1/2"	27	17	84

INSERTO RECUPERABILE AD OCCHIO

RACCORD RECUPERABLE BANJO
 REUSABLE EYE FITTING
 WIEDERVERWENDBARE SCHLAUCHARMATUR MIT ÖSE
 RACOR RECUPERABLE TIPO OJO



Art./Ref.	D mm	Ø interno inch/ Inside Ø inch	Ø interno mm/ Inside Ø mm	CH1
06627	1/4"	1/4"	6	14
16140	3/8"	5/16"	8	15
06628	3/8"	3/8"	10	16

BOCCOLE DI ALLUMINIO PER TUBI BASSA PRESSIONE

DOUILLES POUR FLEXIBLES BASSE PRESSION
 BUSHINGS FOR LOW PRESSURE HYDR. HOSES
 ALU-HÜLSE FÜR NIEDERDRUCK
 CASQUILLO DE ALUMINIO PARA TUBO DE BAJA PRESIÓN

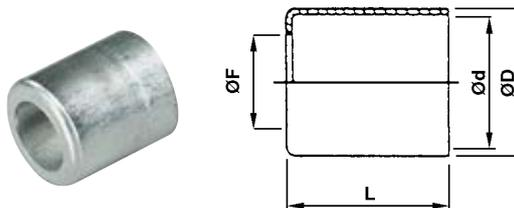

Art./Ref.	Ø interno mm/ Inside Ø mm	Ø esterno mm/ Outside Ø mm	Lunghezza mm/ Lenght mm	F mm
06690	17.5	19	23	12
09188	19	21	25	15
06691	20	22	25	15
09189	23	25	26	16
06692	27	29	30	20
15886	28	30	30	20
09190	30	32	31	21
06693	36	38	36	27

MASCHIO SEDE PIANA PER BASSA PRESSIONE

RACCORD MALE POUR BASSE PRESSION
 STRAIGHT MALE FITTING FOR LOW PRESSURE
 SCHLAUCHFASSUNG STECKER
 MACHO BASE PLANA PARA BAJA PRESIÓN



Art./Ref.	Ø interno inch/ Inside Ø inch	Ø interno mm/ Inside Ø mm	Filettatura esterna/ External Thread	CH1
06712	3/8"	10	3/8"	17
06713	1/2"	13	1/2"	24
06714	3/4"	19	3/4"	30
67790	1"	25	1"	34

FEMMINE DIRITTE PER BASSA PRESSIONE

RACCORDS FEMELLE POUR BASS PRESSION
 STRAIGHT FEMALE FITTINGS FOR LOW PRESSURE
 SCHLAUCHFASSUNG MUFFE
 HEMBRA RECTA PARA BAJA PRESIÓN



Art./Ref.	Ø interno inch/ Inside Ø inch	Ø interno mm/ Inside Ø mm	Filettatura inter- na/Inner Thread	CH1
06700	3/8"	10	3/8"	19
06701	1/2"	13	1/2"	24
06702	3/4"	19	3/4"	32
06703	1"	25	1"	38

FEMMINA 90° PER BASSA PRESSIONE

RACCORD FEM. 90° BASSE PRESSION
 FEMALE 90° FITTING FOR LOW PRESSURE
 90° SCHLAUCHFASSUNG MUFFE
 HEMBRA 90° PARA BAJA PRESIÓN



Art./Ref.	Ø interno inch/ Inside Ø inch	Ø interno mm/ Inside Ø mm	Filettatura interna/ Inner Thread	CH1
06706	3/8"	10	3/8"	19
06707	1/2"	13	1/2"	24
06708	3/4"	19	3/4"	32
06709	1"	25	1"	38

OCCHIO PER BASSA PRESSIONE

RACCORD AVEC BANJO POUR BASSE PRESSION
 EYE FITTING FOR LOW PRESSURE
 ÖSE FÜR NIEDERDRUCK
 OJO PARA BAJA PRESIÓN



Art./Ref.	D mm	Ø interno inch/ Inside Ø inch	Ø interno mm/ Inside Ø mm
06720	3/8"	3/8"	10
06721	1/2"	1/2"	13
06722	3/4"	3/4"	19

TAPPI DI PROTEZIONE MASCHI PER FILETTI FEMMINA

MALE PROTECTING CAPS FOR FEMALE THREADS
 BOUCHON DE PROTECTION MALE POUR FILETS FEMELLE
 SCHUTZKAPPE F. GEWINDE MUFFE
 TAPON DE PROTECCION MACHO PARA ROSCA HEMBRA



Art./Ref.	Filettatura esterna/ External Thread
31743	1/4"
31744	3/8"
31745	1/2"
31749	22x1,5

TAPPI DI PROTEZIONE FEMMINA PER FILETTI MASCHI

FEMALE PROTECTING CAPS FOR MALE THREADS
 BOUCHON DE PROTECTION FEMELLE POUR FILETS MALES
 SCHUTZKAPPE F. GEWINDE STECKER
 TAPON DE PROTECCION HEMBRA PARA ROSCA MACHO



Art./Ref.	Filettatura esterna/ External Thread
31750	1/4"
31751	3/8"
31752	1/2"
31755	18x1,5

NIPPLES DI CONGIUNZIONE

RACCORDS DE JONCTION MÂLES
 MALE - MALE ADAPTORS
 DOPPELSTUTZEN
 RACOR INTERMEDIO M - M

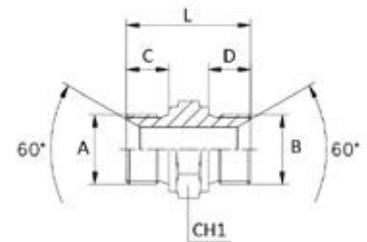

Art./Ref.	A mm	B mm	C mm	D mm	Lunghezza mm/ Lenght mm	CH1	Note/ Notes
67884	1/8"	1/8"	8	8	24	14	-
01698	1/4"	1/4"	11	11	32	19	-
01793	3/8"	3/8"	12	12	35	22	-
17637	3/8"	3/8"	12	12	35	22	FORO / HOLE ø 1mm
31784	3/8"	3/8"	12	12	35	22	FORO / HOLE ø 1,5mm
16134	3/8"	3/8" NPT	12	14,5	32,5	17	-
01794	1/2"	1/2"	14	14	41	27	-
01779	1/2"	1/2" NPT	14	19	41	22	-
10207	5/8"	5/8"	16	16	45	30	-
01795	3/4"	3/4"	16	16	47	32	-
04877	1"	1"	19	19	54	41	-
67885	1"1/4"	1"1/4"	20	20	58	50	-
67886	1"1/2"	1"1/2"	23	23	66	55	-
67887	2"	2"	25	25	74	70	-
03290	14X1,5	14X1,5	12	12	34	19	-
03291	16X1,5	16X1,5	12	12	34	22	-
01861	18X1,5	18X1,5	12	12	36	24	-
03294	20X1,5	20X1,5	14	14	40,5	27	-
01860	22X1,5	22X1,5	14	14	41	27	-

NIPPLES DI RIDUZIONE

RACCORDS DE REDUCTION MÂLES
 MALE-MALE ADAPTORS
 REDUZIER-DOPPELSTUTZEN
 RACOR INTERMEDIO REDUCIDO

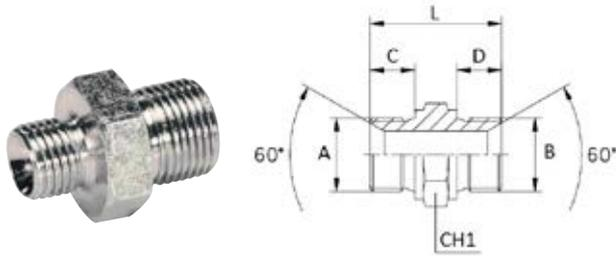

Art./Ref.	A mm	B mm	C mm	D mm	Lunghezza mm/ Lenght mm	CH1
12570	1/8"	1/4"	8	11	28,5	19
01773	1/4"	3/8"	11	12	33,5	22
01780	1/4"	1/2"	11	14	37	27
01789	3/8"	1/2"	12	14	38,5	27
01782	3/8"	1/2" NPT	12	19	39	24
05613	3/8"	3/4"	12	16	42,5	32
67875	1/2"	5/8"	14	16	43	30
01791	1/2"	3/4"	14	16	45	32
16592	1/2"	1"	14	19	49	41
04903	3/4"	1"	16	19	51	41
04904	1"	1"1/4"	19	20	57	50
03292	1/4"	14X1,5	11	12	33	19
03293	1/4"	16X1,5	11	12	33	22
16135	1/4"	18X1,5	11	12	33	24
01787	3/8"	14X1,5	12	12	34,5	22
01493	3/8"	16X1,5	12	12	34,5	22
01788	3/8"	18X1,5	12	12	36	24
04886	3/8"	22X1,5	12	14	38,5	27
01492	1/2"	16X1,5	14	12	38	27
01790	1/2"	18X1,5	14	12	38,5	27
04835	1/2"	20X1,5	14	14	40,5	27
04836	1/2"	22X1,5	14	14	41	27
04829	1/2"	24X1,5	14	14	41	30
67882	3/4"	18X1,5	16	12	42,5	32
31729	12X1,5	14X1,5	12	12	34	19
31730	14X1,5	16X1,5	12	12	34	22
12647	16X1,5	18X1,5	12	12	35,5	24
31732	18X1,5	20X1,5	12	14	38	27
31733	18X1,5	22X1,5	12	14	38	27
31734	20X1,5	22X1,5	14	14	41	27
31735	22X1,5	26X1,5	14	16	45	32

NIPPLES DI CONGIUNZIONE DIN 24°

RACCORDS DE JONCTION MÂLES DIN 24°
 MALE - MALE ADAPTORS DIN 24°
 DOPPELSTUTZEN DIN 24°
 RACOR INTERMEDIO M - M DIN 24°

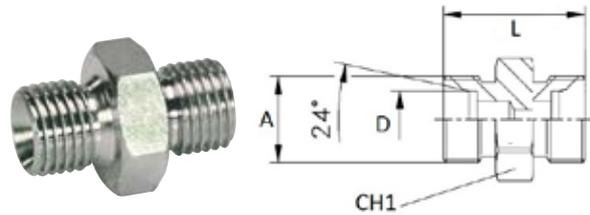

Art./Ref.	A mm	Lunghezza mm/ Lenght mm	CH1	D mm
16526	14X1,5	25	14	8L
16527	16X1,5	27	17	10L
16528	18X1,5	28	19	12L
16529	20X1,5	34	22	12S
16530	22X1,5	30	24	15L

NIPPLES GAS-DIN 24°

RACCORD JONCTION GAS-DIN 24°
 GAS-DIN24° ADAPTORS
 DOPPELSTUTZEN DIN 24° UND GAS
 RACOR INTERMEDIO GAS-DIN 24°

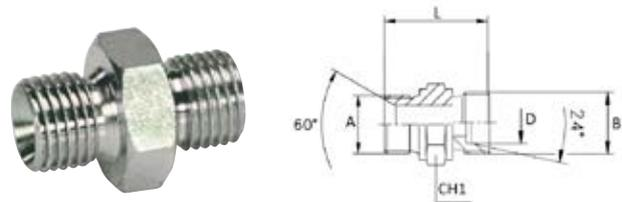

Art./Ref.	A mm	B mm	Lunghezza mm/ Lenght mm	CH1	D mm
16088	1/4"	16X1,5	30	19	10L
16531	1/4"	18X1,5	30	19	12L
16532	3/8"	14X1,5	30,5	22	8L
16533	3/8"	16X1,5	34,5	22	10L
16089	3/8"	18X1,5	31,5	22	12L
16534	1/2"	16X1,5	34	27	10L
16535	1/2"	18X1,5	34	27	12L
16090	1/2"	20X1,5	39	27	12S
16091	1/2"	22X1,5	35	27	15L

NIPPLES JIC-JIC E JIC-GAS

RACCORD JONCTION JIC-JIC ET JIC-GAS
 JIC-JIC AND JIC-GAS ADAPTORS
 DOPPELSTUTZEN JIC 74° UND GAS
 RACOR INTERMEDIO JIC - JIC Y JIC - GAS

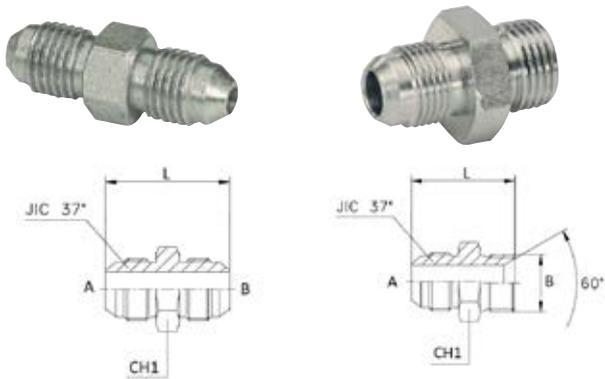

Art./Ref.	A mm	B mm	Lunghezza mm/ Lenght mm	CH1
67871	7/16"-20	7/16"-20	35	12
67872	1/2"-20	1/2"-20	35	14
04493	9/16"-16	9/16"-16	36	17
04494	3/4"-16	3/4"-16	41	22
04495	7/8"-14	7/8"-14	48	24
04486	1"1/16"-12	1"1/16"-12	55	30
04496	1"3/16"-12	1"3/16"-12	60	36
04497	1"5/16"-12	1"5/16"-12	60	36
04498	9/16"-16	1/4"	32	17
04499	9/16"-16	3/8"	33	22
04551	3/4"-16	3/8"	36	22
04139	3/4"-16	1/2"	38	27
04487	1"1/16"-12	3/4"	45	32

NIPPLES PASSAPARETE

RACCORD DE JONCTION MÂLE
 BULKHEAD ADAPTORS
 WANDEINSATZ-NIPPEL
 RACOR PASATABIQUES

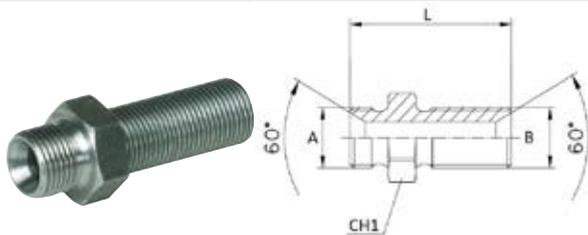

Art./Ref.	A mm	B mm	Lunghezza mm/ Lenght mm	CH1
04212	1/4"	1/4"	55	19
04213	3/8"	3/8"	60	22
04214	1/2"	1/2"	65	27
67870	3/4"	3/4"	65	32

ADATTATORE MASCHIO/FEMMINA DIRITTO BSP E METRICO

ADAPTATEUR MALE/FEMELLE DROIT BSP ET METRIQUE
 BSP AND METRIC MALE/FEMALE STRAIGHT ADAPTOR
 DOPPELSTUTZEN STECKER/MUFFE BSP METRISCH
 ADAPTADOR MACHO/HEMBRA RECTO BSP Y METRICO

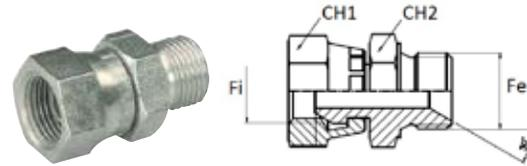

Art./Ref.	Filettatura esterna/ External Thread	Filettatura interna/ Inner Thread	CH1	CH2
06730	1/4"	1/4"	19	19
06731	3/8"	3/8"	22	22
17627	3/8"	1/2"	22	27
06732	1/2"	1/2"	27	27
16160	3/4"	3/4"	32	32
67862	1"	1"	41	41
67863	1"1/4"	1"1/4"	50	50
06565	18x1,5	18x1,5	24	24

ADATTATORE MASCHIO/FEMMINA CURVO 45° BSP

ADAPTATEUR MALE/FEMELLE COURBE 45° BSP
 BSP MALE/FEMALE 45° ADAPTOR
 45° DOPPELSTUTZEN STECKER/MUFFE BSP
 ADAPTADOR MACHO/HEMBRA CURVO 45° BSP

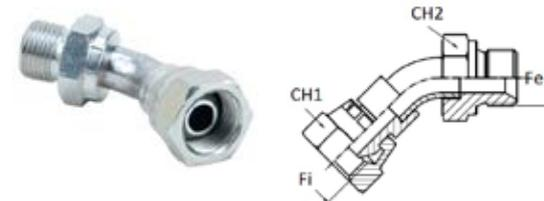

Art./Ref.	Filettatura esterna/ External Thread	Filettatura interna/ Inner Thread	CH1	CH2
58284	1/4"	1/4"	19	19
58285	3/8"	3/8"	22	22
58286	1/2"	1/2"	27	27

ADATTATORE MASCHIO/FEMMINA CURVO A 90°, BSP E METRICO

ADAPTATEUR MALE/FEMELLE COURBE 90° BSP ET METRIQUE
 BSP AND METRIC MALE/FEMALE 90° ADAPTOR
 90° DOPPELSTUTZEN STECKER/MUFFE BSP METRISCH
 ADAPTADOR MACHO/HEMBRA CURVO A 90° BSP Y METRICO

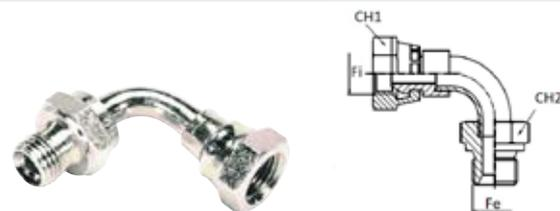

Art./Ref.	Filettatura esterna/ External Thread	Filettatura interna/ Inner Thread	CH1	CH2
02360	1/4"	1/4"	19	19
06530	3/8"	3/8"	22	22
06531	1/2"	1/2"	27	27
16159	3/4"	3/4"	32	32
06563	18x1,5	18x1,5	24	24
06564	22x1,5	22x1,5	27	27

ADATTATORE FEMMINA/FEMMINA DIRITTO BSP E METRICO

ADAPTATEUR FEM. /FEM. DROIT BSP ET METRIQUE
 BSP AND METRIC STRAIGHT FEMALE/FEMALE ADAPTOR
 DOPPELSTUTZEN MUFFE/MUFFE BSP METRISCH
 ADAPTADOR HEMBRA/HEMBRA RECTO BSP Y METRICO

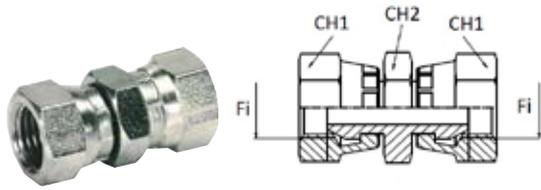

Art./Ref.	Filettatura interna/ Inner Thread	CH1	CH2
06733	1/4"	19	19
06734	3/8"	22	22
06735	1/2"	27	27
16591	3/4"	32	32
67866	1"	41	41
06559	18x1,5	24	24
06560	22x1,5	27	27

ADATTATORE FEMMINA/FEMMINA 45° BSP

ADAPTATEUR FEMELLE/FEMELLE 45° BSP
 BSP FEMALE/FEMALE 45°
 45° DOPPELSTUTZEN MUFFE/MUFFE BSP
 ADAPTADOR HEMBRA/HEMBRA CURVO 45° BSP



Art./Ref.	Filettatura interna/Inner Thread	CH1
67893	1/4"	19
67894	3/8"	22
67895	1/2"	27

ADATTATORE FEMMINA/FEMMINA CURVO A 90°, BSP E METRICO

ADAPTATEUR FEM. /FEM. COURBE 90° BSP ET METRIQUE
 BSP AND METRIC FEMALE/FEMALE 90° ADAPTOR
 90° DOPPELSTUTZEN MUFFE/MUFFE BSP METRISCH
 ADAPTADOR HEMBRA/HEMBRA CURVO A 90° BSP METRICO

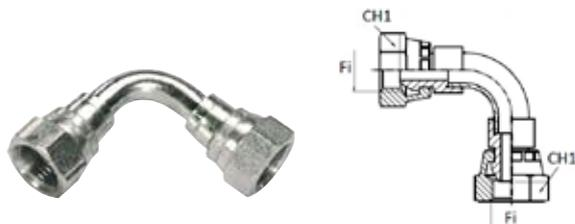

Art./Ref.	Filettatura interna/Inner Thread	CH1
02361	1/4"	19
06532	3/8"	22
06533	1/2"	27
06561	18x1,5	24

ADATTATORE A "L" CON ATTACCO FILETTATO MASCHIO

ADAPTATEUR A "L" FILET MALE
 "L" ADAPTOR WITH MALE THREADED CONNECTOR
 "L" WINKELVERSCHRAUBUNG STECKER
 ADAPTADOR EN "L" CON ROSCA MACHO

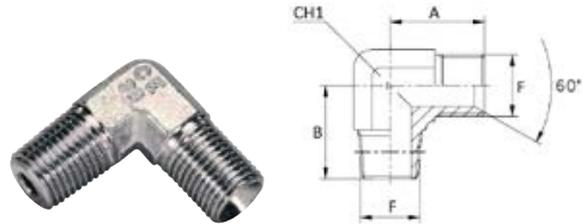

Art./Ref.	Filettatura esterna/ External Thread	A mm	B mm	CH1
03501	1/4"	26	28	14
03502	3/8"	29	31	19
03504	1/2"	34	37,5	22
03503	3/4"	41	40	27

ADATTATORE A "L" CON ATTACCO FILETTATO FEMMINA

ADAPTATEUR A "L" FILETÉ FEMELLE
 "L" ADAPTOR WITH FEM. THREADED CONNECTOR
 "L" WINKELVERSCHRAUBUNG MUFFE
 ADAPTADOR EN "L" CON ROSCA HEMBRA

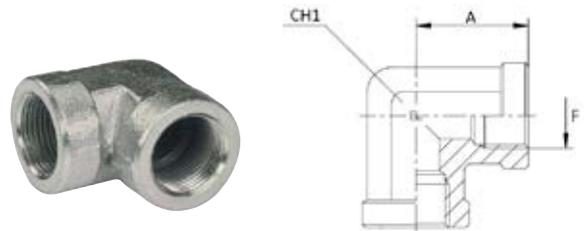

Art./Ref.	Filettatura interna/ Inner Thread	A mm	CH1
03574	1/4"	22,5	19
03575	3/8"	26	22
03576	1/2"	31	27
03577	3/4"	34,5	33

ADATTATORE A 90° MASCHIO-FEMMINA GIREVOLE

ADAPTATEUR 90° MALE-FEM. TOURNANT
 REVOLVING MALE-FEMALE ADAPTOR 90°
 DREHBARER ADAPTER 90° STECKER-MUFFE
 ADAPTADOR A 90° MACHO - HEMBRA GIRATORIO

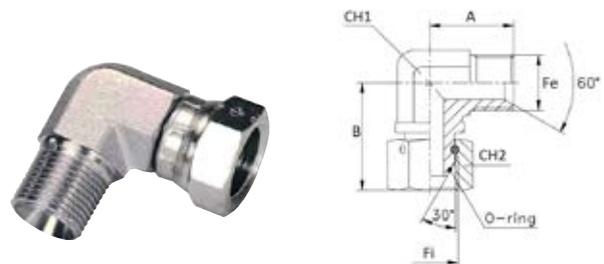

Art./Ref.	Filettatura esterna/ External Thread	Filettatura interna/ Inner Thread	A mm	B mm	CH1	CH2
09191	1/4"	1/4"	26	33	14	19
09192	3/8"	3/8"	29	37	19	22
09193	1/2"	1/2"	34	43	22	27
67891	3/4"	3/4"	41	53,5	27	32

ADATTATORE A "L" CON ATTACCO FILETTATO MASCHIO - FEMMINA

ADAPTEUR A "L" FILETÉ MALE - FEMELLE
 "L" ADAPTOR WITH MALE - FEM. THREADED CONNECTOR
 "L" WINKELVERSCHRAUBUNG S. - M.
 ADAPTADOR EN "L" CON ROSCA MACHO - HEMBRA

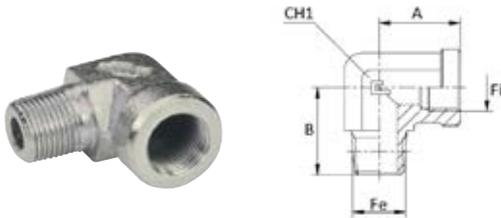

Art./Ref.	Filettatura interna/ Inner Thread	Filettatura esterna/ External Thread	A mm	B mm	CH1
03564	1/4"	1/4"	22,5	28	19
03565	3/8"	3/8"	26	31	22
03566	1/2"	1/2"	31	37,5	27
03562	3/4"	3/4"	34,5	40	33

ADATTATORE A T CON ATTACCO FILETTATO MASCHIO

ADAPTEUR A "T" FILET MALE
 "T" ADAPTOR WITH MALE THREADED CONNECTOR
 "T" VERSCHRAUBUNG STECKER
 ADAPTADOR RN "T" CON ROSCA MACHO

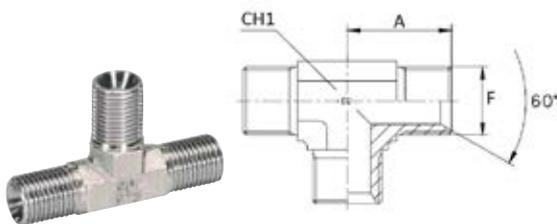

Art./Ref.	Filettatura esterna/ External Thread	A mm	CH1
03509	1/4"	26	14
03510	3/8"	29	19
03512	1/2"	34	22
03513	3/4"	41	27

ADATTATORE A "T" CON ATTACCO FILETTATO FEMMINA

ADAPTEUR A "T" FILET FEMELLE
 "T" ADAPTOR WITH FEMALE THREADED CONNECTOR
 "T" VERSCHRAUBUNG MUFFE
 ADAPTADOR EN "T" CON ROSCA HEMBRA

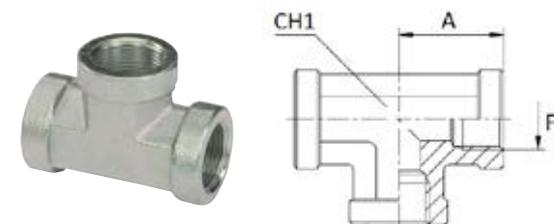

Art./Ref.	Filettatura interna/ Inner Thread	A mm	CH1
03505	1/4"	22,5	19
03506	3/8"	26	22
03507	1/2"	31	27
03508	3/4"	34,5	33

ADATTATORE A "T" M-M-F GIREVOLE

ADAPTEUR "T" M-M-FEM. TOURNANT
 M-M-F REVOLVING "T" ADAPTOR
 DREHBARER ADAPTER "T" S-S-M
 ADAPTADOR EN "T" M - M - F GIRATORIO

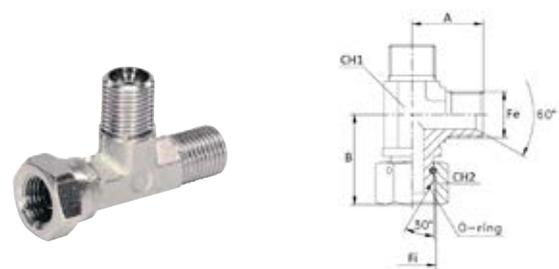

Art./Ref.	Filettatura esterna/ External Thread	Filettatura interna/ Inner Thread	A mm	B mm	CH1	CH2
09194	1/4"	1/4"	26	33	14	19
09195	3/8"	3/8"	29	37	19	22
09196	1/2"	1/2"	34	43	22	27
67898	3/4"	3/4"	41	53,5	27	32

ADATTATORE A "T" M-F GIREVOLE-M

ADAPTEUR "T" M-F TOURNANT - M
 M-F REVOLVING - M "T" ADAPTOR
 DREHBARER ADAPTER "T" S-M-S
 ADAPTADOR EN "T" M - F GIRATORIO - M

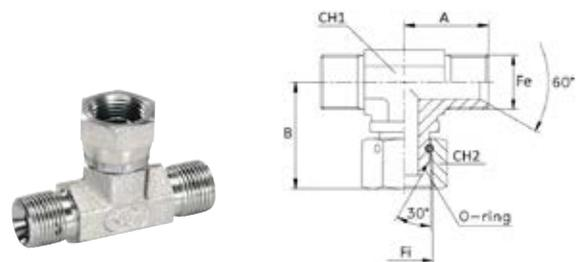

Art./Ref.	Filettatura esterna/ External Thread	Filettatura interna/ Inner Thread	A mm	B mm	CH1	CH2
09197	1/4"	1/4"	26	33	14	19
09198	3/8"	3/8"	29	37	19	22
09199	1/2"	1/2"	34	43	22	27
67897	3/4"	3/4"	41	53,5	27	32

GIUNTO GIREVOLE IN LINEA

RACCORD TOURNANT
 REVOLVING COUPLING
 DREHBARE KUPPLUNGSSTÜCK
 RACOR GIRATORIO

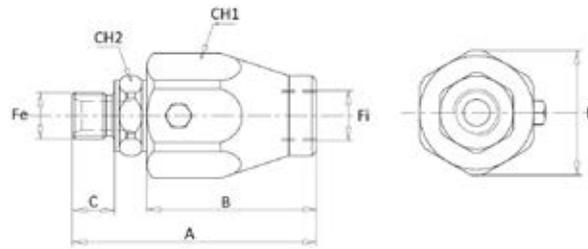

Art./Ref.	Filettatura esterna/ External Thread	Filettatura interna/ Inner Thread	A mm	B mm	C mm	D mm	CH1	CH2	Note/Notes
09202	1/4"	1/4"	61	42	11	33	30	19	PORTATA MAX / MAX FLOW 25LT/MIN - PRESSIONE MAX IN ROTAZIONE / MAX ROTATION PRESSURE 200 BAR - PRESSIONE MAX / MAX PRESSURE 400 BAR
09200	3/8"	3/8"	66	44	14	37	34	24	PORTATA MAX / MAX FLOW 35LT/MIN - PRESSIONE MAX IN ROTAZIONE / MAX ROTATION PRESSURE 200 BAR - PRESSIONE MAX / MAX PRESSURE 400 BAR
09201	1/2"	1/2"	71	47	15	40	36	27	PORTATA MAX / MAX FLOW 60LT/MIN - PRESSIONE MAX IN ROTAZIONE / MAX ROTATION PRESSURE 150 BAR - PRESSIONE MAX / MAX PRESSURE 300 BAR
19502	1"	1"	98	65	21	54,5	50	41	PORTATA MAX / MAX FLOW 180LT/MIN - PRESSIONE MAX IN ROTAZIONE / MAX ROTATION PRESSURE 100 BAR - PRESSIONE MAX / MAX PRESSURE 300 BAR

GIUNTO GIREVOLE 90°

RACCORD TOURNANT 90°
 90° REVOLVING COUPLING
 DREHBARE 90°-KUPPLUNGSSTÜCK
 RACOR GIRATORIO 90°

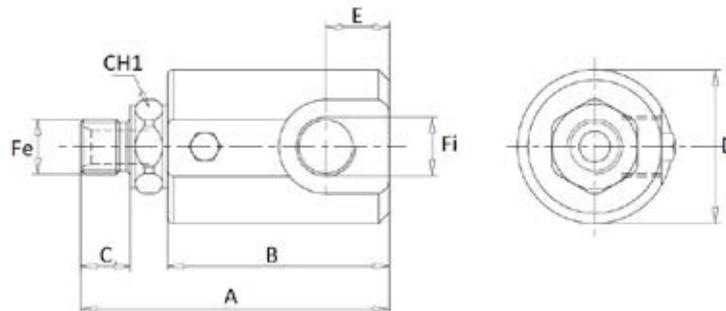

Art./Ref.	Filettatura esterna/ External Thread	Filettatura interna/ Inner Thread	A mm	B mm	C mm	D mm	E mm	CH1	Note/Notes
09283	1/4"	1/4"	69	50	11	34	11	19	PORTATA MAX / MAX FLOW 25LT/MIN - PRESSIONE MAX IN ROTAZIONE / MAX ROTATION PRESSURE 200 BAR - PRESSIONE MAX / MAX PRESSURE 400 BAR
09284	3/8"	3/8"	76	54	14	38	13	24	PORTATA MAX / MAX FLOW 35LT/MIN - PRESSIONE MAX IN ROTAZIONE / MAX ROTATION PRESSURE 200 BAR - PRESSIONE MAX / MAX PRESSURE 400 BAR
09285	1/2"	1/2"	87	63	15	40	14	27	PORTATA MAX / MAX FLOW 60LT/MIN - PRESSIONE MAX IN ROTAZIONE / MAX ROTATION PRESSURE 150 BAR - PRESSIONE MAX / MAX PRESSURE 300 BAR
19503	3/4"	3/4"	104	74	19	54,5	19,5	34	PORTATA MAX / MAX FLOW 100LT/MIN - PRESSIONE MAX IN ROTAZIONE / MAX ROTATION PRESSURE 150 BAR - PRESSIONE MAX / MAX PRESSURE 300 BAR
19504	1"	1"	119	87	21	60	24	41	PORTATA MAX / MAX FLOW 180LT/MIN - PRESSIONE MAX IN ROTAZIONE / MAX ROTATION PRESSURE 100 BAR - PRESSIONE MAX / MAX PRESSURE 300 BAR

OCCHIO FILETTATO

BANJO FILETÉ
 THREADED BANJO
 GEWINDERINGSTUCK
 OJO ROSCADO

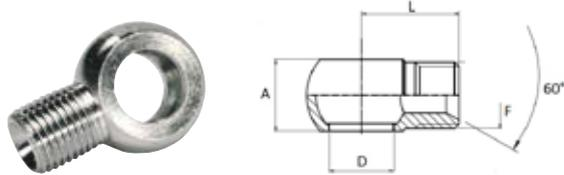

Art./Ref.	D mm	Filettatura esterna/ External Thread	A mm	Lunghezza mm/ Length mm
01981	1/4"	1/4"	14	25
12620	3/8"	1/4"	17	28
01821	3/8"	3/8"	17	28
16080	1/2"	3/8"	22	32
01822	1/2"	1/2"	22	32
67904	16	16x1,5	17	28
01820	18	18x1,5	20	30

OCCHIO FILETTATO CON BATTUTA

BANJO FILETÉ
 THREADED BANJO
 GEWINDERINGSTÜCK
 OJO ROSCADO

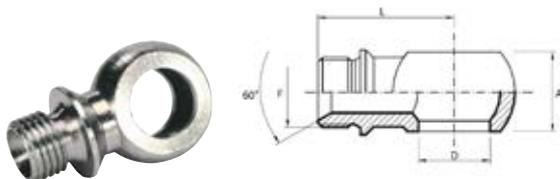

Art./Ref.	D mm	Filettatura esterna/ External Thread	A mm	Lunghezza mm/ Length mm
02464	1/4"	1/4"	14	31
04250	3/8"	3/8"	17	40
04249	3/8"	3/8"	17	45
04251	1/2"	1/2"	22	45
02465	18	18x1,5	17	40

BOCCHETTONI PER ANELLI ORIENTABILI FILETTO GAS

VIS PERCÉE
 DRILLED SCREWS FOR BANJO
 HOHLSCHRAUBEN
 TORNILLO RACOR ORIENTABLE SIMPLE

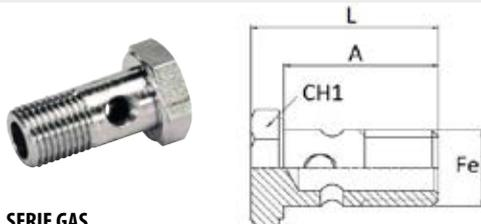

SERIE GAS

Art./Ref.	Filettatura esterna/ External Thread	Lunghezza mm/ Length mm	A mm	CH1
67847	1/8"	25	19	14
01830	1/4"	32	26	19
01833	3/8"	39	32	22
01834	1/2"	46,5	38,5	27
01835	3/4"	57	47	32
04831	1"	71	59	40

BOCCHETTONI PER ANELLI ORIENTABILI FILETTO METRICO

VIS PERCÉE
 DRILLED SCREWS FOR BANJO
 HOHLSCHRAUBEN
 TORNILLO RACOR ORIENTABLE SIMPLE

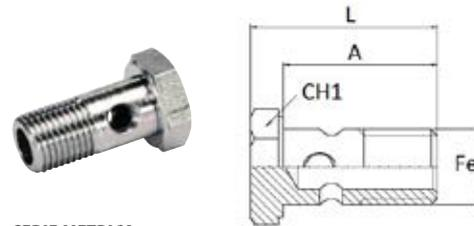

SERIE METRICA

Art./Ref.	Filettatura esterna/ External Thread	Lunghezza mm/ Length mm	A mm	CH1
01800	8x1	21	16	12
01804	10x1	25	19	14
01805	12x1,5	29,5	24	17
01831	14x1,5	33	27	19
01814	16x1,5	39	32	22
01832	18x1,5	43,5	32	24
04832	20x1,5	46	38	27
04833	22x1,5	47	39	27

BOCCHETTONI A 8 FORI PER ANELLI ORIENTABILI

VIS PERCÉES A 8 TROUS POUR BANJOS
 8 HOLES DRILLED SCREWS FOR BANJO
 8 LÖCHER HOHLSCHRAUBEN
 TORNILLO RACOR ORIENTABLE DOBLE

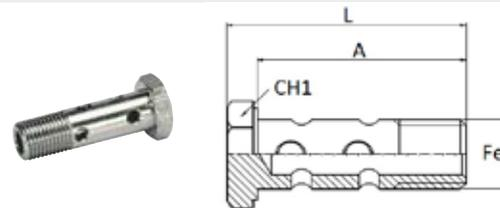

Art./Ref.	Filettatura esterna/ External Thread	Lunghezza mm/ Length mm	A mm	CH1
02460	1/4"	48,5	42	19
02689	3/8"	59	52	22
02690	1/2"	72	64	27
09206	14x1,5	48,5	42	19
02463	18x1,5	61,5	54,5	24
02462	22x1,5	72	64	27

CONTRODADO PER PASSAPARETE

ECROUS POUR RACCORD DE JONCTION
 NUT FOR BULKHEAD
 STELMUTTER FÜR WANDEINSATZ
 CONTRATUERCA PARA PASATABIQUES

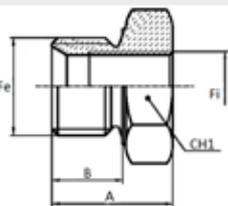

Art./Ref.	Filettatura esterna/ External Thread	CH1
04482	1/4"	17
04483	3/8"	22
04484	1/2"	27
12290	18x1,5	24

BUSSOLA BASSA DI RIDUZIONE GAS
DOUILLES DE REDUCTION
REDUCING PLUGS
REDUZIERHÜLSEN
TUERCA DE REDUCCIÓN CILINDRICA

Art./Ref.	Filettatura esterna/ External Thread	Filettatura interna/ Inner Thread	A mm	B mm	CH1
67806	1/4"	1/8"	18	11	19
01024	3/8"	1/4"	21	13	22
19450	1/2"	1/4"	23	14	27
01023	1/2"	3/8"	23	14	27
67807	3/4"	3/8"	26	16	32
01025	3/4"	1/2"	26	16	32
67809	1"	1/2"			41
67808	1"	3/4"	30	18	40
67810	1"1/4"	3/4"	37	22	55
67811	1"1/4"	1"	37	22	55

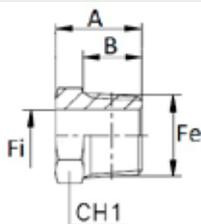
BUSSOLA BASSA DI RIDUZIONE NPT
DOUILLES DE REDUCTION
REDUCING PLUGS
REDUZIERHÜLSEN
TUERCA DE REDUCCIÓN CONICA

Art./Ref.	Filettatura esterna/ External Thread	Filettatura interna/ Inner Thread	A mm	B mm	CH1
01886	3/8" NPT	1/4"	20,5	14,5	19
01001	1/2" NPT	3/8"	26	19	24
01206	3/4" NPT	3/8"	26	19	27
01006	3/4" NPT	1/2"	26	19	27

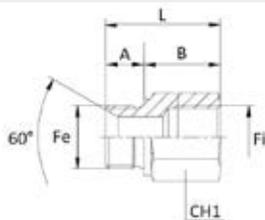
PROLUNGA MASCHIO-FEMMINA
PROLUNGATEUR MALE-FEMELLE
MALE-FEMALE ADAPTOR
VERLÄNGERUNGSTÜCK S. -M.
ADAPTADOR MACHO - HEMBRA

Art./Ref.	Filettatura esterna/ External Thread	Filettatura interna/ Inner Thread	Lunghezza mm/ Length mm	A mm	B mm	CH1
01979	1/4"	1/4"	36	11	25	19

Art./Ref.	Filettatura esterna/ External Thread	Filettatura interna/ Inner Thread	Lunghezza mm/ Length mm	A mm	B mm	CH1
16079	1/4"	1/4"	51	11	40	19
04878	3/8"	3/8"	38	13	25	22
01032	3/8"	3/8"	53	13	40	22
04879	1/2"	1/2"	39	14	25	27
01033	1/2"	1/2"	59	14	45	27
05284	3/4"	3/4"	56	16	40	32
67817	3/4"	3/4"	66	16	50	32
67818	1"	1"	78	18	60	41
67819	1"1/4"	1"1/4"	60	20	40	50
67820	1"1/2"	1"1/2"	65	23	42	55
67821	2"	2"	87	25	62	65
02456	18x1,5	18x1,5	53,5	13,5	40	24
02457	22x1,5	22x1,5	59	14	45	27

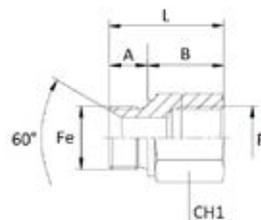
RIDUZIONE MASCHIO-FEMMINA
REDUCTEURS MALE-FEMELLE
MALE-FEMALE REDUCING ADAPTOR
REDUZIERSTÜCK STECKER-MUFFE
REDUCTOR MACHO - HEMBRA

Art./Ref.	Filettatura esterna/ External Thread	Filettatura interna/ Inner Thread	Lunghezza mm/ Length mm	A mm	B mm	CH1
67792	1/8"	1/4"	29	8	21	19
04839	1/4"	3/8"	36	11	25	22
67793	1/4"	1/2"	36	11	25	27
04488	3/8"	1/4"	38	13	25	22
01031	3/8"	1/2"	36	13	25	27
14769	1/2"	1/4"	39	14	25	27
01966	1/2"	3/8"	39	14	25	27
01005	1/2"	3/4"	54	14	40	32
12573	3/4"	3/8"	56	16	40	32
12574	3/4"	1"	56	16	40	41
67798	1"	1"1/4"	55	18	37	50
67799	1"	1"1/2"	60	18	42	55
67801	1"1/4"	1"1/2"	70	20	50	55
67803	1"1/2"	1"1/4"	70	23	47	55
04881	3/8"	16x1,5	38	13	25	22
04841	3/8"	18x1,5	38	13	25	24
01003	1/2"	20x1,5	39	14	25	27
04489	1/2"	22x1,5	39	14	25	27
02458	18x1,5	3/8"	38,5	13,5	25	24
07748	18x1,5	1/2"	38,5	13,5	25	27
19452	22x1,5	3/8"	39	14	25	27
04485	22x1,5	1/2"	39	14	25	27

PROLUNGA FEMMINA-FEMMINA

PROLUNGATEUR FEMELLE-FEMELLE
 FEMALE-FEMALE ADAPTOR
 VERLÄNGERUNGSTÜCK MUFFE-MUFFE
 ADAPTADOR HEMBRA - HEMBRA

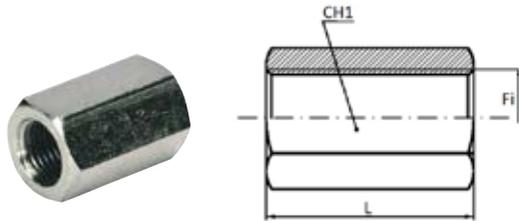

Art./Ref.	Filettatura interna/ Inner Thread	Lunghezza mm/ Length mm	CH1
02453	1/4"	25	19
02454	3/8"	30	22
02452	1/2"	35	27
02451	3/4"	40	32
67815	1"	45	41
67816	1 1/4"	55	50

MEZZO NIPLO A SALDARE

DEMI RACCORD MÂLE À SOUDER
 WELDABLE HALF-ADAPTOR
 NIPPEL ZUM SCHWEISSEN
 EMPALME SOLDABLE

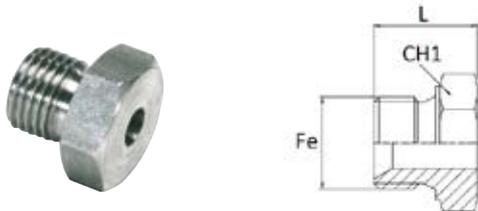

Art./Ref.	Filettatura esterna/ External Thread	Lunghezza mm/ Length mm	CH1
04096	1/4"	18	19
01692	3/8"	21	22
01693	1/2"	23	27
04858	3/4"	26	32
67860	1 1/2"	38	55
36437	16x1,5	21	22
16593	18x1,5	24	24

OCCHIO A SALDARE

BANJO A SOUDER
 WELDABLE BANJO
 RINGÖSEN ZUM SCHWEISSEN
 ORIENTABLE PARA JOLDAR

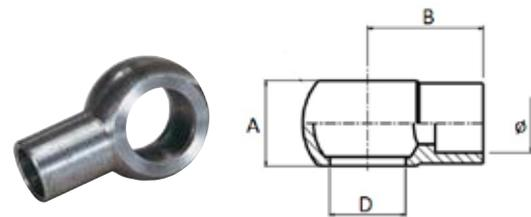

Art./Ref.	D mm	Ø mm	A mm	B mm
01824	14	10	14	24
01797	16	14	18	28
01825	18	14	20	29
01796	1/4"	8	14	24
04861	1/4"	10	14	24
01827	3/8"	12	18	28
01828	1/2"	16	22	32

TAPPI ESAGONALI MASCHIO

BOUCHON EXAGONAUX MALES
 MALE HEXAGONAL PLUG
 SECHSKANTIGER STOPSEL
 TAPÓN HEXAGONAL MACHO

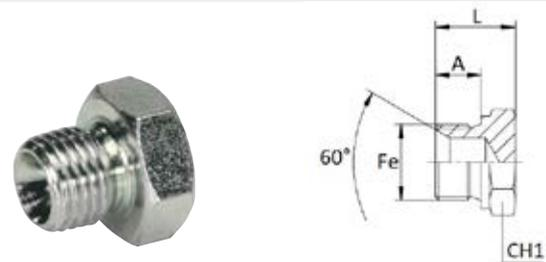

Art./Ref.	Filettatura esterna/ External Thread	Lunghezza mm/ Length mm	A mm	CH1
04847	1/4"	18	11	19
04848	3/8"	18	13	22
04849	1/2"	23	14	27
04850	3/4"	26	16	32
31738	1"	30	18	41
67830	1 1/4"	37	22	50
67831	1 1/2"	38	23	55
67832	2"	40	25	70
04851	14x1,5	18	11	19
04852	16x1,5	21	13	22
04853	18x1,5	21,5	13,5	24
04854	20x1,5	23	14	27
04869	22x1,5	23	14	27

TAPPI MASCHI A BRUGOLA

MALE SOCKET CAPS
BOUCHON MALE CREUSE
SECHSKANT SCHUTZ STECKER
TAPON MACHO



Art./Ref.	A mm	Filettatura esterna/ External Thread	CH1	Lunghezza mm/ Length mm
31791	18	1/4"	6	15
31792	22	3/8"	8	15
31793	26	1/2"	10	18
31794	32	3/4"	12	20
31795	40	1"	17	21
31796	19	14x1,5	6	15
31800	27	22x1,5	10	18

TAPPI GIREVOLI FEMMINA

BOUCHONS TOURNANTS FEMELLE
REVOLVING FEMALE PLUGS
DREHBARER MUFFE STÖPSEL
TAPÓN GIRATORIO HEMBRA

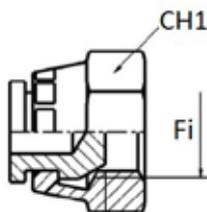

Art./Ref.	Filettatura interna/Inner Thread	CH1
04542	1/4"	19
04543	3/8"	22
04544	1/2"	27
31736	3/4"	32
31737	1"	38
67839	1"1/4"	46
67840	1"1/2"	55
67841	2"	65
04578	18x1,5	24
04579	22x1,5	27

ASSORTIMENTO RONDELLE IN RAME 400 PZ

ASSORTIMENT DE RONDELLES 400 PCS
COPPER WASHERS KIT 400 PCS
SORTIMENT KUPFERDICHTUNGEN 400 STK
SURTIDO ARANDELAS DE COBRE 400 PCS

Assortimento rondelle in rame
con espositore da 400 pezzi

washer kit with box 400



Art./Ref.	Tipo/Type	Ø interno inch/Inside Ø inch	Ø interno mm/Inside Ø mm	Ø esterno mm/Outside Ø mm	Sezio- ne/ Section
84778	ASSORTIMENTO RONDELLE IN RAME 400 PZ	-	-	-	-
02704	30 PEZZI	-	6	12	1,5

Art./Ref.	Tipo/Type	Ø interno inch/Inside Ø inch	Ø interno mm/Inside Ø mm	Ø esterno mm/Outside Ø mm	Sezio- ne/ Section
02705	30 PEZZI	-	8	14	1,5
02706	30 PEZZI	-	10	16	1,5
02707	30 PEZZI	-	12	18	1,5
02708	40 PEZZI	1/4"	13	19	1,5
01902	30 PEZZI	-	14	20	1,5
02709	30 PEZZI	-	16	22	1,5
01906	40 PEZZI	3/8"	17	23	1,5
01910	30 PEZZI	-	18	24	1,5
05285	20 PEZZI	-	20	26	1,5
01913	40 PEZZI	1/2"	21	27	1,5
05286	20 PEZZI	-	22	28	1,5
06535	10 PEZZI	5/8"	24	30	1,5
01919	10 PEZZI	3/4"	27	33	1,5
01990	10 PEZZI	1"	33	41	1,5

RONDELLE IN RAME

RONDELLES (EN CUIVRE)
COPPER WASHER
KUPFERDICHTUNGEN
ARTANDELA DE COBRE



Art./Ref.	Ø interno inch/ Inside Ø inch	Ø interno mm/ Inside Ø mm	Ø esterno mm/ Outside Ø mm	Sezione/ Section
02704	-	6	12	1,5
19443	-	8	12	1,5
02705	-	8	14	1,5
19440	-	10	14	1
02706	-	10	16	1,5
02707	-	12	18	1,5
02708	1/4"	13	19	1,5
19445	-	14	18	1,5
01902	-	14	20	1,5
02709	-	16	22	1,5
01906	3/8"	17	23	1,5
01910	-	18	24	1,5
19446	-	18	25	1,5
05285	-	20	26	1,5
01913	1/2"	21	27	1,5
05286	-	22	28	1,5
06535	5/8"	24	30	1,5
01919	3/4"	27	33	1,5
01990	1"	33	41	1,5

ART. 01905

ASSORTIMENTO RONDELLE IN RAME CON ESPOSITORE

ASSORTIMENT DE RONDELLES AVEC BOITE-PRESENTOIR
COPPER WASHER KIT WITH BOX
SORTIMENT KUPFERDICHTUNGEN MIT AUSSTELLBOX
SURTIDO ARANDELAS DE COBRE



Art./Ref.	Note/Notes	Ø interno inch/ Inside Ø inch	Ø interno mm/ Inside Ø mm	Ø esterno mm/ Outside Ø mm	Sezione/ Section
01905	ASSORTIMENTO RONDELLE IN RAME	-	-	-	-
02704	200 PEZZI	-	6	12	1,5
02705	200 PEZZI	-	8	14	1,5
02706	100 PEZZI	-	10	16	1,5
02707	200 PEZZI	-	12	18	1,5
02708	100 PEZZI	1/4"	13	19	1,5
01902	200 PEZZI	-	14	20	1,5
02709	100 PEZZI	-	16	22	1,5
01906	150 PEZZI	3/8"	17	23	1,5
01910	100 PEZZI	-	18	24	1,5
01913	150 PEZZI	1/2"	21	27	1,5
01919	25 PEZZI	3/4"	27	33	1,5
01990	25 PEZZI	1"	33	41	1,5

RONDELLE IN ALLUMINIO

RONDELLES ALUMINIUM
ALUMINIUM WASHER
ALU - UNTERLEGSCHIEBE
ARANDELA EN ALUMINIO

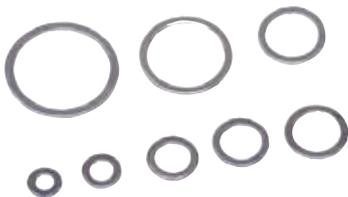

Art./Ref.	Ø interno inch/Inside Ø inch	Ø interno mm/Inside Ø mm	Ø esterno mm/Outside Ø mm	Sezione/Section	conf/conf
11068	-	6	10	1.5	100 PEZZI / PIECES
11069	-	8	12	1.5	100 PEZZI / PIECES
11070	-	10	16	1.5	100 PEZZI / PIECES
11071	-	12	18	1.5	100 PEZZI / PIECES
11072	1/4"	13	19	1.5	100 PEZZI / PIECES
11073	-	14	20	1.5	100 PEZZI / PIECES
11074	-	16	22	1.5	100 PEZZI / PIECES
11075	3/8"	17	23	1.5	100 PEZZI / PIECES
11076	-	18	24	1.5	100 PEZZI / PIECES
11077	-	20	26	1.50	100 PEZZI / PIECES
11078	1/2"	21	27	1.5	100 PEZZI / PIECES
11079	-	22	28	1.50	100 PEZZI / PIECES
11081	3/4"	27	33	1.5	100 PEZZI / PIECES

ART. 11083

ASSORTIMENTO RONDELLE IN ALLUMINIO CON ESPOSITORE

ASSORTIMENT DE RONDELLES EN ALLUMINIUM AVEC BOITE-PRESENTOIR
ALUMINIUM WASHER KIT WITH BOX
SORTIMENT ALU - UNTERLEGSCHIEBE MIT SCHACHTEL
SURTIDO ARANDELAS DE ALUMINIO CON EXPOSITO



Art./Ref.	Tipo/Type
11068	M6 (200 PEZZI / PIECES)
11069	M8 (200 PEZZI / PIECES)
11070	M10 (100 PEZZI / PIECES)
11071	M12 (200 PEZZI / PIECES)
11072	1/4" (100 PEZZI / PIECES)
11073	M14 (200 PEZZI / PIECES)
11074	M16 (100 PEZZI / PIECES)
11075	3/8" (150 PEZZI / PIECES)
11076	M18 (100 PEZZI / PIECES)
11078	1/2" (150 PEZZI / PIECES)
11081	3/4" (25 PEZZI / PIECES)

GOMMA

JOINT "BONDED" AVEC BAGUE INTERIEURE EN CAOUTCHOUC
BONDED SEALS WITH RUBBER RING INSIDE
BONDED-DICHTUNGEN MIT NYLON-RINGE
ARANDELA METALBUNA

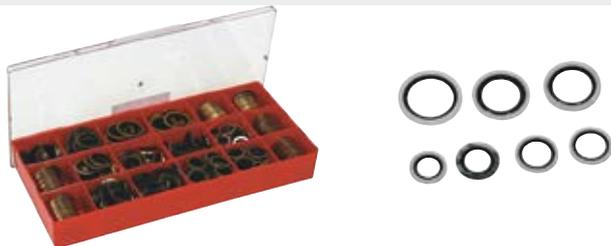

Art./Ref.	Ø interno inch/Inside Ø inch	Ø interno mm/Inside Ø mm	Ø esterno mm/Outside Ø mm	conf/conf
04907	1/4"	13.7	20.7	100 PEZZI / PIECES
04908	3/8"	17.25	23.95	100 PEZZI / PIECES
04909	1/2"	21.5	28.7	100 PEZZI / PIECES
06534	5/8"	23.5	31.8	50 PEZZI / PIECES
04910	3/4"	27.05	35.05	50 PEZZI / PIECES
04911	1"	33.85	42.95	50 PEZZI / PIECES
84748	1"1/4"	42.93	52.38	25 PEZZI / PIECES
04913	14	14.85	22.3	50 PEZZI / PIECES
04914	16	16.7	24	50 PEZZI / PIECES
04915	18	18.15	25.55	50 PEZZI / PIECES
04917	22	22.45	31.9	50 PEZZI / PIECES
04918	24	24.25	33.4	50 PEZZI / PIECES

ART. 02466
ASSORTIMENTO RONDELLE AUTOCENTRANTI "BONDED" CON ESPOSITORE
PRESENTOIR RONDELLES "BONDED"
BONDED SEALS KIT WITH BOX
SORTIMENT KUPERDICHTUNGEN MIT AUSSTELLBOX
SURTIDO ARANDELAS METALBUNA

Art./Ref.	Tipo/Type
04907	1/4" (50 PEZZI / PIECES)
04908	3/8" (100 PEZZI / PIECES)
04909	1/2" (50 PEZZI / PIECES)
06534	5/8" (25 PEZZI / PIECES)
04910	3/4" (30 PEZZI / PIECES)
04911	1" (25 PEZZI / PIECES)
04913	M14 (50 PEZZI / PIECES)
04914	M16 (50 PEZZI / PIECES)
04915	M18 (40 PEZZI / PIECES)
04917	M22 (40 PEZZI / PIECES)
04918	M24 (50 PEZZI / PIECES)

ANELLI DI TENUTA O-RING
JOINTS OR POUR
O-RING FOR
O-RING FÜR
JUNTAS TÓRICAS

Art./Ref.	Ø interno mm/Inside Ø mm	Ø esterno mm/Outside Ø mm	Tipo/Type	Sezione/Section
05427	2.9	6.46	OR-006	1.78
05428	4.47	8.03	OR-008	1.78
05429	6.07	9.63	OR-010	1.78
05430	7.65	11.21	OR-011	1.78
05431	9.25	12.81	OR-012	1.78
05432	12.42	15.98	OR-014	1.78
05433	9.19	14.43	OR-110	2.62
05434	10.77	16.01	OR-111	2.62
05435	12.37	17.61	OR-112	2.62
05436	13.94	19.18	OR-113	2.62
05437	15.54	20.78	OR-114	2.62
05438	17.12	22.36	OR-115	2.62
05439	18.72	23.96	OR-116	2.62
05440	20.29	25.53	OR-117	2.62
05441	21.89	27.13	OR-118	2.62
05442	18.64	25.7	OR-210	3.53
05443	20.22	27.28	OR-211	3.53
05444	21.82	28.88	OR-212	3.53
05445	23.4	30.46	OR-213	3.53
05446	24.99	32.05	OR-214	3.53
05447	26.58	33.64	OR-215	3.53

Art./Ref.	Ø interno mm/Inside Ø mm	Ø esterno mm/Outside Ø mm	Tipo/Type	Sezione/Section
05448	28.17	35.23	OR-216	3.53
05449	29.75	36.81	OR-217	3.53
05450	31.34	38.4	OR-218	3.53
05451	32.92	39.98	OR-219	3.53
05452	34.52	41.58	OR-220	3.53
05453	36.09	43.15	OR-221	3.53
05454	37.69	44.75	OR-222	3.53
05455	40.87	47.93	OR-223	3.53
05456	44.04	51.1	OR-224	3.53
05457	47.22	54.28	OR-225	3.53
05458	50.39	57.45	OR-226	3.53

ASSORTIMENTO ANELLI O-RING
ASSORTIMENT JOINTS O-RING
O-RING KIT
O-RING SORTIMENT
SURTIDO JUNTAS TORICAS

Art./Ref.
04916

KIT UTENSILI PER O-RING
O-RING TOOL KIT
KIT OUTILS POUR O-RING
WERKZEUGSATZ FUER O-RINGE
KIT APEROS PARA O-RING

Art./Ref.
34136

KIT UTENSILI PER GUARNIZIONI
SEALING TOOL KIT
KIT OUTILS POUR JOINTS
WERKZEUGSATZ FUER DICHTUNGEN
KIT APEROS PARA JUNTAS

Art./Ref.
34137

PINZA PER GUARNIZIONI

PINSE POUR JOINTS
SEALS CLAMP
ZANGE FUER DICHTUNGEN
PINZA PARA GUARNICION



Art./Ref.
37457

BLOCCHETTO FERMATUBO AD 1 POSTO

COLLIER ATTACHE FLEXIBLE (1 POSTE)
CLAMPS FOR HOSE (SIGLE SERIE)
ROHRSCHELLE (EINFACH)
ABRAZADERA DE UN TUBO

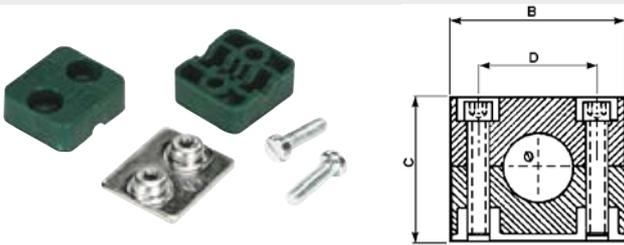

Art./Ref.	Ø mm	B mm	C mm	D mm
02413	6	35	30	20
02414	8	35	30	20
02546	10	35	30	20
02529	12	35	30	20
02411	14	41	36	26
02547	15	41	36	26
02530	16	41	36	26
02548	18	41	36	26
02549	20	48	38	33
02531	22	48	38	33
02550	25	48	38	33
02532	28	57	45	40

BLOCCHETTO FERMATUBO A 2 POSTI

COLLIER ATTACHE FLEXIBLE (2 POSTES)
CLAMPS FOR HOSE (DOUBLE SERIES)
ROHRSCHEMLE (DOPPELT)
ABRAZADERA DE DOS TUBOS

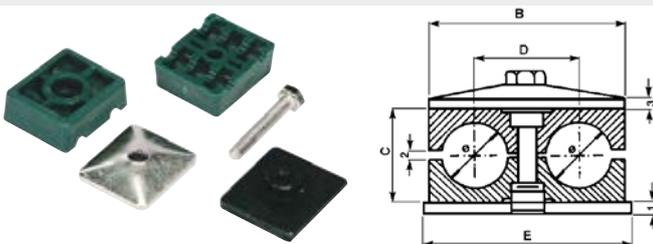

Art./Ref.	Ø mm	B mm	C mm	D mm	E mm
02435	6	36	25	20	37
02436	8	36	25	20	37
02552	10	36	25	20	37
02533	12	36	25	20	37
02437	14	53	26	29	55

Art./Ref.	Ø mm	B mm	C mm	D mm	E mm
02553	15	53	26	29	55
02534	16	53	26	29	55
02554	18	53	26	29	55
02555	20	67	37	36	70
02535	22	67	37	36	70
02556	25	67	37	36	70
02536	28	82	42	45	85

INNESTI RAPIDI A VALVOLA FASTER MASCHIO

COUPLEURS RAPIDES A CLAPET "FASTER"
QUICK COUPLING POPPET VALVE "FASTER"
SCHNELLKUPPLUNG MIT PILZVENTIL "FASTER"
ENCHUFE RAPIDO CON PITON "FASTER"



Faster

Innesti rapidi a valvola Faster maschio per collegare/scollegare linee idrauliche o pneumatiche rapidamente senza bisogno di strumenti.

Art./Ref.	Filettatura interna/ Inner Thread	Tipo/Type	Pressione max (bar)/ Pression max (bar)	Note/Note
75950	1/4"	MASCHIO / MALE	350	AGRICOLO / AGRICULTURAL
75812	3/8"	MASCHIO / MALE	300	-
72773	1/2"	MASCHIO / MALE	300	-
75952	3/4"	MASCHIO / MALE	250	AGRICOLO / AGRICULTURAL/
84666	1"	MASCHIO / MALE	250	-

INNESTI RAPIDI VALVOLA FASTER FEMMINA

COUPLEURS RAPIDES A CLAPET "FASTER"
QUICK COUPLING POPPET VALVE "FASTER"
SCHNELLKUPPLUNG MIT PILZVENTIL "FASTER"
ENCHUFE RAPIDO CON PITON "FASTER"



Faster

Innesti rapidi a valvola Faster femmina per collegare/scollegare linee idrauliche o pneumatiche rapidamente senza bisogno di strumenti

Art./Ref.	Filettatura interna/ Inner Thread	Tipo/Type	Pressione max (bar)/ Pression max (bar)	Note/Note
75951	1/4"	FEMMINA / FEMALE	350	AGRICOLO / AGRICULTURAL
75811	3/8"	FEMMINA / FEMALE	300	-
72774	1/2"	FEMMINA / FEMALE	300	-
75953	3/4"	FEMMINA / FEMALE	250	AGRICOLO / AGRICULTURAL
84665	1"	FEMMINA / FEMALE	250	-

INNESTI RAPIDI A SFERA FASTER MASCHIO

COUPLEURS RAPIDES A BILLE "FASTER"
 QUICK COUPLING BALL TYPE "FASTER"
 SCHNELLKUPPLUNG MIT KUGELVENTIL "FASTER"
 ENCHUFE RAPIDO CON BOLA "FASTER"

Faster

Innesti rapidi a sfera Faster maschio per collegare/scollegare rapidamente linee idrauliche o pneumatiche

Art./Ref.	Filettatura interna/ Inner Thread	Tipo/Type	Pressione max (bar)/ Pression max (bar)	Note/Note
75954	1/4"	MASCHIO / MALE	250	AGRICOLO / AGRICULTURAL
75956	3/8"	MASCHIO / MALE	250	-
75813	1/2"	MASCHIO / MALE	200	-
75958	3/4"	MASCHIO / MALE	170	AGRICOLO / AGRICULTURAL

INNESTI RAPIDI A SFERA FASTER FEMMINA

COUPLEURS RAPIDES A BILLE "FASTER"
 QUICK COUPLING BALL TYPE "FASTER"
 SCHNELLKUPPLUNG MIT KUGELVENTIL "FASTER"
 ENCHUFE RAPIDO CON BOLA "FASTER"

Faster

Innesti rapidi a sfera Faster maschio per collegare/scollegare rapidamente linee idrauliche o pneumatiche

Art./Ref.	Filettatura interna/Inner Thread	Tipo/Type	Pressione max (bar)/ Pression max (bar)	Note/Note
75955	1/4"	FEMMINA / FEMALE	250	AGRICOLO / AGRICULTURAL
75957	3/8"	FEMMINA / FEMALE	250	AGRICOLO / A GRICULTURAL
75814	1/2"	FEMMINA / FEMALE	200	-
75959	3/4"	FEMMINA / FEMALE	170	AGRICOLO / AGRICULTURAL

INNESTI RAPIDI PUSH-PULL FASTER FEMMINA

COUPLEURS RAPIDES TYPE PUSH-PULL "FASTER"
 PUSH-PULL QUICK COUPLING POPPET VALVE "FASTER"
 ABREISSKUPPLUNG PUSH-PULL "FASTER"
 ENCHUFE RAPIDO PUSH-PULL "FASTER"

Faster

Innesti rapidi push-pull Faster per collegare/scollegare rapidamente linee idrauliche o pneumatiche

Art./Ref.	Filettatura interna/ Inner Thread	Tipo/Type	Pressione max (bar)/ Pression max (bar)
75815	1/2"	FEMMINA / FEMALE	300
75960	1/2" NPT	FEMMINA / FEMALE	300

INNESTI RAPIDI TIPO "PUSH-PULL" FASTER

COUPLEURS RAPIDES TYPE PUSH-PULL "FASTER"
 PUSH-PULL QUICK COUPLING POPPET VALVE "FASTER"
 ABREISSKUPPLUNG PUSH-PULL "FASTER"
 ENCHUFE RAPIDO PUSH-PULL "FASTER"

Faster

Art./Ref.	Filettatura interna/ Inner Thread	Tipo/Type	Pressione max (bar)/ Pression max (bar)
75961	1/2"	MASCHIO / MALE	300
75962	1/2" NPT	MASCHIO / MALE	300

INNESTI RAPIDI CON ATTACCO FILETTATO MASCHIO 24° "FASTER"

COUPLEURS RAPIDES ATTACHE FIL. MALE 24° "FASTER"
 QUICK COUPLING POPPET VALVE MALE CONNECTION 24° "FASTER"
 SCHNELLKUPPLUNGEN MIT AUSSENGEWINDE 24° "FASTER"
 ACOPLE RAPIDO CON ATAQUE ROSCADO MACHO 24° "FASTER"

Faster

Art./Ref.	Filettatura esterna/External Thread	Tipo/Type	Pressione max (bar)/ Pression max (bar)	Note/Note
75963	14x1,5	MASCHIO / MALE	300	8L
75965	16x1,5	MASCHIO / MALE	300	10L
75967	18x1,5	MASCHIO / MALE	300	12L
75971	22x1,5	MASCHIO / MALE	300	15L

INNESTI RAPIDI CON ATTACCO FILETTATO MASCHIO DIN 2353 FASTER

COUPLEURS RAPIDES ATTACHE FIL MALE DIN 2353 FASTER
 INNESTI RAPIDI CON ATTACCO FILETTATO MASCHIO DIN 2353 FASTER
 SCHNELLKUPPLUNGEN MIT AUSSENGEWINDE DIN 2353 "FASTER"
 ACOPLE RAPIDO CON ATAQUE ROSCADO MACHO DIN 2353 FASTER

Faster

Art./Ref.	Filettatura esterna/External Thread	Tipo/Type	Pressione max (bar)/ Pression max (bar)	Note/Note
75964	14x1,5	FEMMINA / FEMALE	300	8L
75966	16x1,5	FEMMINA / FEMALE	300	10L
75968	18x1,5	FEMMINA / FEMALE	300	12L
75972	22x1,5	FEMMINA / FEMALE	300	15L

INNESTI RAPIDI CON ATTACCO FILETTATO MASCHIO DIN 2353 PASSAPARE-TE FASTER

COUPLEURS RAPIDES ATTACHE FIL. MALE DIN 2353
 THREADED MALE QUICK COUPLING FASTER DIN 2353
 SCHNELLKUPPLUNGEN MIT AUSSENGWINDE DIN 2353 "FASTER"
 ACOPLER RAPIDO CON ATAQUE ROSCADO MACHO DIN 2353 PASAPARED FASTER



Faster

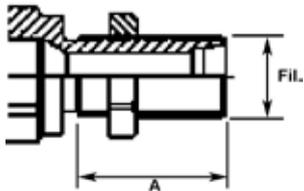

Art./Ref.	A mm	Filettatura esterna/External Thread	Tipo/Type	Pressione max (bar)/Pression max (bar)	Note/Note
75973	35	18x1,5	MASCHIO / MALE	300	12L
75975	35	22x1,5	MASCHIO / MALE	300	15L

INNESTI RAPIDI CON ATTACCO FILETTATO MASCHIO DIN 2353 PASSAPARE-TE FASTER

COUPLEURS RAPIDES ATTACHE FIL. FEM. DIN 2353 'FASTER'
 THREADED MALE QUICK COUPLING FASTER DIN 2353
 SCHNELLKUPPLUNGEN MIT AUSSENGWINDE DIN 2353 "FASTER"
 ACOPLER RAPIDO CON ATAQUE ROSCADO MACHO DIN 2353 PASAPARED FASTER



Faster

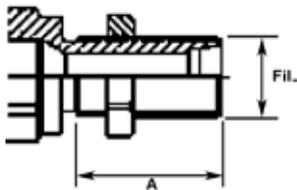

Art./Ref.	A mm	Filettatura esterna/External Thread	Tipo/Type	Pressione max (bar)/Pression max (bar)	Note/Note
75974	35	18x1,5	FEMMINA / FEMALE	300	12L
75976	35	22x1,5	FEMMINA / FEMALE	300	15L

VALVOLE PER IMPIANTI A FRENATURA FASTER

CLAPET DE FREINAGE 'FASTER'
 BRAKE VALVE FASTER
 VENTILE FUER BREMSANLAGE "FASTER"
 VALVULA FRENADO FASTER



Faster

Art./Ref.	Filettatura esterna/External Thread	CH1	Tipo/Type
75977	18x1,5	32	MASCHIO / MALE
75978	20x1,5	32	MASCHIO / MALE

VALVOLE PER IMPIANTI A FRENATURA FASTER

CLAPET DE FREINAGE 'FASTER'
 BRAKE VALVE FASTER
 VENTILE FUER BREMSANLAGE "FASTER"
 VALVULA FRENADO FASTER



Faster

Art./Ref.	Filettatura interna/Inner Thread	CH1	Tipo/Type
75979	18x1,5	32	FEMMINA / FEMALE
75980	1/2"	32	FEMMINA / FEMALE

INNESTI RAPIDI FASTER A FACCIA PIANA

COUPLEURS RAPIDES PLATS 'FASTER'
 FLAT FACE QUICK COUPLING FASTER
 FLACHDICHTENDE SCHNELLKUPPLUNGEN "FASTER"
 ACOPLER RAPIDO CARA PLANA "FASTER"

Faster

Gli innesti rapidi Faster a faccia piana sono studiati per evitare dispersioni di fluido durante la connessione/disconnessione di linee idrauliche o pneumatiche. Estrema facilità di pulizia. Conformi alle normative ISO 16028 e Htma.

Art./Ref.	Filettatura esterna/ External Thread	Filettatura interna/ Inner Thread	Tipo/Type	Pressione max (bar)/ Pression max (bar)	Note/Note
76400	-	1/4"	Maschio	350	DIMENSIONE NOMINALE 1/4" NOMINAL SIZE 1/4"
76401	-	1/4"	Femmina	350	DIMENSIONE NOMINALE 1/4" NOMINAL SIZE 1/4"
76402	-	3/8"	Maschio	350	DIMENSIONE NOMINALE 3/8" NOMINAL SIZE 3/8"
76403	-	3/8"	Femmina	350	DIMENSIONE NOMINALE 3/8" NOMINAL SIZE 3/8"
84664	18X1,5 12L	-	maschio / male	350	DIMENSIONE NOMINALE 3/8" NOMINAL SIZE 3/8"
84663	18X1,5 12L	-	femmina/ female	350	DIMENSIONE NOMINALE 3/8" NOMINAL SIZE 3/8"
76404	-	1/2"	maschio	350	DIMENSIONE NOMINALE 3/8" NOMINAL SIZE 3/8"
76405	-	1/2"	femmina	350	DIMENSIONE NOMINALE 3/8" NOMINAL SIZE 3/8"
80805	-	1/2"	maschio / male	350	DIMENSIONE NOMINALE 1/2" NOMINAL SIZE 1/2"
80806	-	1/2"	femmina/ female	350	DIMENSIONE NOMINALE 1/2" NOMINAL SIZE 1/2"
76406	-	3/4"	maschio / male	350	DIMENSIONE NOMINALE 1/2" NOMINAL SIZE 1/2"
76407	-	3/4"	femmina	350	DIMENSIONE NOMINALE 1/2" NOMINAL SIZE 1/2"
80807	-	3/4"	maschio / male	350	DIMENSIONE NOMINALE 3/4" NOMINAL SIZE 3/4"
80808	-	3/4"	femmina/ female	350	DIMENSIONE NOMINALE 3/4" NOMINAL SIZE 3/4"
84658	-	1"	maschio / male	350	DIMENSIONE NOMINALE 3/4" NOMINAL SIZE 3/4"
84657	-	1"	femmina/ female	350	DIMENSIONE NOMINALE 3/4" NOMINAL SIZE 3/4"
84660	-	1"	maschio / male	350	DIMENSIONE NOMINALE 1" NOMINAL SIZE 1"
84659	-	1"	femmina/ female	350	DIMENSIONE NOMINALE 1" NOMINAL SIZE 1"

INNESTI A VITE "FASTER" SERIE CVV

A VISSER "FASTER" CVV
 SCREW TOGETHER "FASTER" CVV SERIES
 SCHRAUBKUPPLUNGEN "FASTER" CVV
 ENCHUFE RAPIDO A VITARE "FASTER" CVV

Faster
INNESTI A VITE "FASTER" SERIE CVV
SCREW TOGETHER "FASTER" CVV SERIES

Art./Ref.	Tipo/Type	Filettatura interna/ Inner Thread	Pressione max (bar)/ Pression max (bar)	Note/Notes
89323	femmina/ female	1/4"	500	Innesto a Vite
89324	maschio/ male	1/4"	500	-
89325	femmina/ female	3/8"	400	-
89326	maschio/ male	3/8"	400	-
89327	femmina/ female	1/2"	400	-
89328	maschio/ male	1/2"	400	-
89329	femmina/ female	3/4"	350	-
89330	maschio/ male	3/4"	350	-
89331	femmina/ female	1"	350	-
89332	maschio/ male	1"	350	-

INNESTO RAPIDO PUSH PULL "FASTER"

COUPLEUR PUSH PULL "FASTER"
 PUSH PULL QUICK COUPLING "FASTER"
 SCHNELLKUPPLUNG PUSH PULL "FASTER"
 ENCHUFE RAPIDO PUSH PULL "FASTER"

Faster
INNESTO RAPIDO PUSH PULL "FASTER" PUSH PULL QUICK COUPLING "FASTER"

Art./Ref.	Ø interno inch/Inside Ø inch	Filettatura interna/Inner Thread	Filettatura esterna/External Thread	Tipo/Type
84509	1/2"	-	22X1,5	FASTER 4SRPV081/22F H
89305	1/2"	1/2"	-	FASTER 4SRPV08 12GF H
89306	1/2"	1/2" NPT	-	FASTER 4SRPV08 12NF H
89307	1/2"	-	3/4"-16 UNF	FASTER 4SRPV08 12SF H

PIASTRE MULTICONNESSIONE DA 3/8" FASTER

PLAQUE MULTICONNECTION "FASTER"
 QUICK-RELEASE MULTICONNECTION "FASTER"
 MULTIKUPPLUNG "FASTER"
 PLACA MULTICONEXION "FASTER"



Consentono una drastica riduzione del tempo di collegamento, l'assenza di perdite di fluido e inclusioni di aria durante le operazioni di connessione/disconnessione

Art./Ref.	Ø interno inch/ Inside Ø inch	Filettatura interna/ Inner Thread	Tipo/Type	Note/Notes
78770	3/8"	3/8"	4 POSIZIONI / POSITION FASTER 2P506-4-38G FC	PARTE FISSA / FIXED BLOCK
78771	3/8"	3/8"	4 POSIZIONI / POSITION FASTER 2P506-4-38G MC	PARTE MOBILE / MOBILE BLOCK
78772	3/8"	3/8"	6 POSIZIONI / POSITION FASTER 2P5066-6-38G FC	PARTE FISSA / FIXED BLOCK
78773	3/8"	3/8"	6 POSIZIONI / POSITION FASTER 2P5066-6-38G MC	PARTE MOBILE / MOBILE BLOCK

PIASTRE MULTICONNESSIONE DA 3/8" FILETTO 1/2" FASTER

PLAQUE MULTICONNECTION "FASTER"
 QUICK-RELEASE MULTICONNECTION "FASTER"
 MULTIKUPPLUNG "FASTER"
 PLACA MULTICONEXION "FASTER"



Art./Ref.	Ø interno inch/ Inside Ø inch	Filettatura interna/ Inner Thread	Tipo/Type	Note/Notes
84661	3/8"	1/2"	2 POSIZIONI / POSITION FASTER 2P206-2-12G FC	PARTE FISSA / FIXED BLOCK
84662	3/8"	1/2"	2 POSIZIONI / POSITION FASTER 2P206-2-12G MC	PARTE MOBILE / MOBILE BLOCK
84716	3/8"	1/2"	4 POSIZIONI / POSITION FASTER 2P506-4-12G FC	PARTE FISSA / FIXED BLOCK
84717	3/8"	1/2"	4 POSIZIONI / POSITION FASTER 2P506-4-12G MC	PARTE MOBILE / MOBILE BLOCK
84718	3/8"	1/2"	6 POSIZIONI / POSITION FASTER 2P606-6-12G FC	PARTE FISSA / FIXED BLOCK
84719	3/8"	1/2"	6 POSIZIONI / POSITION FASTER 2P606-6-12G MC	PARTE MOBILE / MOBILE BLOCK

PIASTRE MULTICONNESSIONE DA 1/2" FASTER

PLAQUE MULTICONNECTION "FASTER"
 QUICK-RELEASE MULTICONNECTION "FASTER"
 MULTIKUPPLUNG "FASTER"
 PLACA MULTICONEXION "FASTER"

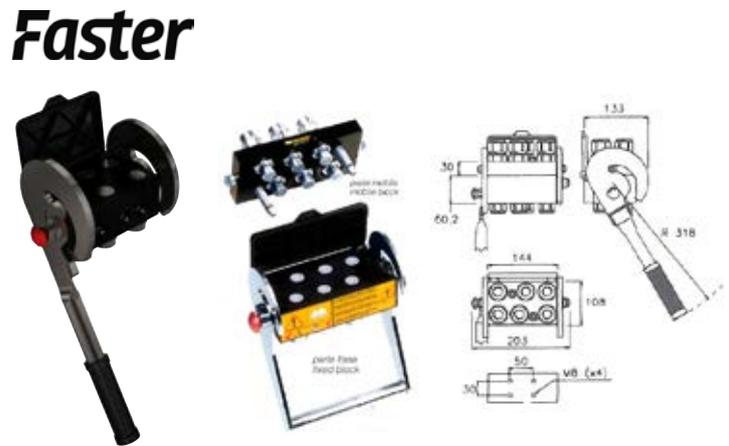

Art./Ref.	Filettatura interna/ Inner Thread	Ø interno inch/ Inside Ø inch	Tipo/Type	Note/Notes
78774	1/2"	1/2"	4 POSIZIONI / POSITION FASTER 2P508-4-12-G FC	PARTE FISSA / FIXED BLOCK
78775	1/2"	1/2"	4 POSIZIONI / POSITION FASTER 2P508-4-12G MC	PARTE MOBILE / MOBILE BLOCK
78776	1/2"	1/2"	5 POSIZIONI / POSITION FASTER 2P608-5-12G FC	PARTE FISSA / FIXED BLOCK
78777	1/2"	1/2"	5 POSIZIONI / POSITION FASTER 2P608-5-12G MC	PARTE MOBILE / MOBILE BLOCK
78778	1/2"	1/2"	6 POSIZIONI / POSITION FASTER 2P608-6-12G FC	PARTE FISSA / FIXED BLOCK
78779	1/2"	1/2"	6 POSIZIONI / POSITION FASTER 2P608-6-12G MC	PARTE MOBILE / MOBILE BLOCK

INNESTI RAPIDI PER PIASTRA MULTICONNESSIONE

COUPLEUR RAPID POUR PLAQUE MULTICONNECTION
 QUICK COUPLINGS FOR MULTICONNECTION
 SCHNELLKUPPLUNGEN FÜR MEHR VERBINDUNG PLATTE
 ENCHUFE RAPIDO PARA PLACA MULTICONEXION



**INNESTI RAPIDI PER PIASTRA MULTICONNESSIONE
 QUICK COUPLINGS FOR MULTICONNECTION**

Art./Ref.	Filettatura interna/ Inner Thread	Tipo/Type	Note/Notes
83881	3/8"	MASCHIO / MALE	ART. 78771 - 78773
83882	3/8"	FEMMINA / FEMALE	ART. 78770 - 78772
83883	1/2"	MASCHIO / MALE	ART. 78775 - 78777 - 78779
83884	1/2"	FEMMINA / FEMALE	ART. 78774 - 78776 - 78778

**ART. 84508
KIT TAPPI PER RECUPERO OLIO**

SYSTEME DE COLLECTE D'HUILE
OIL COLLECTION SYSTEM
STAUBKAPPE MIT OLSAMMELVORRICHTUNG
TAPA DE PROTECCION PARA ACOPLE RAP.

Faster

Art./Ref.	Note/Notes
84508	INTERASSE / WHEELBASE 55mm

**ART.84507
KIT SERBATOIO PER RECUPERO OLIO DA 300CC**

KIT RESERVOIR POUR REPRISE HUILE
OIL TANK FOR FEMALE QUICK COUPLINGS
TANK FUER OELVERWERTUNG
KIT DEPOSITO PARA RECUPERACION DE ACIETE

Faster

Art./Ref.	Note/Notes
84507	Il kit completo comprende il serbatoio, il raccordo a Y ed un metro di tubo in gomma antolio.

"FASTER"

CABOCHONS ANTI-POUSSIÈRE POUR COUPLEURS RAPIDES
ANTI DUST CAPS FOR MALE QUICK COUPLINGS "FASTER"
STAUBSCHUTZ F.SCHNELLK.
TAPA DE PROTECCION PARA ACOPLE RAP.

Faster

Art./Ref.	Tipo/Type	Note/Note
81210	1/2"	ROSSO / RED
81211	1/2"	NERO / BLACK
81212	1/2"	GIALLO / YELLOW
81213	1/2"	BLU / BLUE
84752	1/2"	VERDE / GREEN

TAPPI DI PROTEZIONE PARAPOLVERE PER INNESTI RAPIDI MASCHI FACCIA PIANA "FASTER"

CABOCHONS ANTI-POUSSIÈRE POUR COUPLEURS RAPIDES
ANTI DUST CAPS FOR MALE QUICK COUPLINGS "FASTER"
STAUBSCHUTZ F.SCHNELLK.
TAPA DE PROTECCION PARA ACOPLE RAP.

Faster

Art./Ref.	Tipo/Type	Note/Notes
84720	1/4"	Art. 76400
84722	3/8"	Art. 76402 - 76404
84724	1/2"	Art.80805 - 76406
84726	3/4"	Art.80807 - 84658
84728	1"	Art.84660

TAPPI DI PROTEZIONE PARAPOLVERE PER INNESTI RAPIDI FEMMINA "FASTER"

CABOCHONS ANTI-POUSSIÈRE POUR COUPLEURS RAPIDES
DUST CAPS FOR FEMALE QUICK COUPLING FASTER
STAUBSCHUTZ F.SCHNELLK.
TAPA DE PROTECCION PARA ACOPLE RAP.

Faster

Art./Ref.	Tipo/Type	Note/Note
81214	1/2"	ROSSO / RED
81215	1/2"	NERO / BLACK
81216	1/2"	GIALLO / YELLOW
81217	1/2"	BLU / BLUE
84753	1/2"	VERDE / GREEN

FALSA FEMMINA PER INNESTO RAPIDO MASCHIO

FAUSSE FEM. POUR COUPLEUR RAPID MALE
PROTECTION FOR MALE QUICK COUPLEUR
HALTERUNG FÜR SCHNLLKUPPLUNG
FALSA HEMBRA PARA ENCHUFE RÁPIDO MACHO



Art./Ref.	Note/Notes
12614	PER INNESTI MASCHIO DA 1/2" / FOR QUICK COUPLING MALE 1/2"

TAPPI DI PROTEZIONE PARAPOLVERE PER INNESTI RAPIDI FEMMINA FACCIA PIANA "FASTER"

CABOCHONS ANTI-POUSSIÈRE POUR COUPLEURS RAPIDES
 ANTI DUST CAPS FOR FEMALE QUICK COUPLING FASTER
 STAUBSCHUTZ FÜR SCHNELLKUPPLUNG
 TAPA DE PROTECCION PARA ACOPLE RAP.



Faster

Art./Ref.	Tipo/Type	Note/Notes
84721	1/4"	Art.76401
84723	3/8"	Art.76403 - 76405
84725	1/2"	Art. 80806 - 76407
84727	3/4"	Art.80808 - 84657
84729	1"	Art.84659

FALSA FEMMINA PER INNESTO RAPIDO MASCHIO "FASTER"

FAUSSE FEM. POUR COUPLEUR RAPID MALE "FASTER"
 PROTECTION FOR MALE QUICK COUPLEUR "FASTER"
 HALTERUNG FÜR SCHNELLKUPPLUNG "FASTER"
 FALSA HEMBRA PARA ENCHUFE RÁPIDO MACHO "FASTER"



Faster

Art./Ref.	Note/Notes
84532	PER INNESTI MASCHIO DA 1/2" / FOR QUICK COUPLING MALE 1/2"

TAPPI DI PROTEZIONE PARAPOLVERE PER INNESTI RAPIDI

CABOCHONS ANTI-POUSSIÈRE POUR COUPLEURS RAPIDES
 ANTI DUST CAPS FOR QUICK COUPLERS
 STAUBSCHUTZ FÜR SCHNELLKUPPLUNGEN
 TAPÓN GUARDAPOLVO PARA ENCHUFE RÁPIDO



Art./Ref.	Tipo/Type	Note/Note
01854	1/4"	ROSSO / RED
01856	3/8"	ROSSO / RED
01858	1/2"	ROSSO / RED
12183	1/2"	BLU / BLUE
37261	1/2"	VERDE / GREEN
37262	1/2"	GIALLO / YELLOW

TAPPI DI PROTEZIONE PARAPOLVERE PER INNESTI RAPIDI

CABOCHONS ANTI-POUSSIÈRE POUR COUPLEURS RAPIDES
 ANTI DUST CAPS FOR QUICK COUPLERS
 STAUBSCHUTZ FÜR SCHNELLKUPPLUNGEN
 TAPÓN GUARDAPOLVO PARA ENCHUFE RÁPIDO



Art./Ref.	Tipo/Type	Note/Note
01853	1/4"	ROSSO / RED
01857	3/8"	ROSSO / RED
01859	1/2"	ROSSO / RED
12184	1/2"	BLU / BLUE
37271	1/2"	VERDE / GREEN
37272	1/2"	GIALLO / YELLOW
37273	1/2"	NERO / BLACK

TAPPI PROTETTIVI AUTOMATICI PER INNESTI RAPIDI

CABOCHON AUTOMATIQUE POUR COUPLEURS
 AUTOMATIC PROTECTIVE CAP FOR QUICKCOUPLERS
 AUTOMATISCHE SCHUTZKAPPE FÜR SCHNELLKUPPLUNGER
 TAPOS DE PROTECCIÓN ENCHUFE RÁPIDO



Faster

Tappi protettivi automatici per innesti rapidi 1/2" colorati

Art./Ref.	Tipo/Type	Note/Note
09792	1/2"	BLU / BLUE
12185	1/2"	ROSSO / RED
37283	1/2"	VERDE / GREEN
37284	1/2"	GIALLO / YELLOW
37285	1/2"	NERO / BLACK

TAPPI DI PROTEZIONE PARAPOLVERE PER INNESTI RAPIDI IN BLISTER

CABOCHONS ANTI-POUSSIÈRE POUR COUPLEURS RAPIDES AVEC BLISTER
 ANTI DUST CAPS FOR QUICK COUPLERS IN BLISTER
 STAUBSCHUTZ FÜR SCHNELLKUPPLUNGEN MIT BLISTER
 TAPÓN GUARDAPOLVO PARA ENCHUFE RÁPIDO EN BLISTER



Art./Ref.	Tipo/Type	conf/conf	Note/Note
01858C	1/2"	5	ROSSO / RED
12183C	1/2"	5	BLU / BLUE

TAPPI DI PROTEZIONE PARAPOLVERE PER INNESTI RAPIDI IN BLISTER

CABOCHONS ANTI-POUSSIÈRE POUR COUPLEURS RAPIDES AVEC BLISTER
 ANTI DUST CAPS FOR QUICK COUPLERS IN BLISTER
 STAUBSCHUTZ FÜR SCHNELLKUPPLUNGEN MIT BLISTER
 TAPÓN GUARDAPOLVO PARA ENCHUFE RÁPIDO EN BLISTER



Art./Ref.	Tipo/Type	conf/conf	Note/Note
01859C	1/2"	5	ROSSO / RED
12184C	1/2"	5	BLU / BLUE

TAPPO PROTETTIVO AUTOMATICO PER INNESTI RAPIDI IN BLISTER

CABOCHON AUTOMATIQUE POUR COUPLEURS AVEC BLISTER
 AUTOMATIC PROTECTIVE CAP FOR QUICKCOUPLERS IN BLISTER
 AUTOMATISCHE SCHUTZKAPPE FÜR SCHNELLKUPPLUNGEN MIT BLISTER
 TAPOS DE PROTECCIÓN ENCHUFE RÁPIDO Á EN BLISTER



Art./Ref.	Tipo/Type	conf/conf	Note/Note
09792C	1/2"	2	BLU / BLUE
12185C	1/2"	2	ROSSO / RED

TUBO IN ACCIAIO BONDERIZZATO PER CIRCUITI OLEODINAMICI

TUBE ACIER BONDERISE POUR CIRCUITS HYDRAULIQUES
 BONDERIZED STEEL TUBES FOR OLEODINAMIC PLANTS
 STAHLROHRE FÜR HYDRAULIKANLAGEN
 TUBO EN ACERO PARA CIRCUITO OLEODINAMICO



Art./Ref.	Ø esterno mm/ Outside Ø mm	Sezione/Section	Note/Notes
12294	6	1	LUNGHEZZA / LENGTH 3MT
03514	8	1	LUNGHEZZA / LENGTH 3MT
02349	10	1.5	LUNGHEZZA / LENGTH 3MT
03515	12	1.5	LUNGHEZZA / LENGTH 3MT
03516	15	1.5	LUNGHEZZA / LENGTH 3MT

OGIVA DIN 3861

BAGUES
 CUTTING RING DIN 3861
 SCHNEIDRINGE
 CONO DE CIERRE

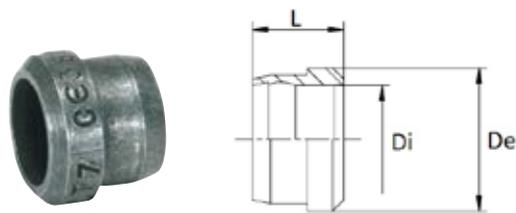

Art./Ref.	Ø interno mm/ Inside Ø mm	Ø esterno mm/ Outside Ø mm	Lunghezza mm/ Length mm	Tipo/Type
12292	6	10	9,5	6L
02438	8	12	9,5	8L
02440	10	14	10	10L
02441	12	16	10	12L
02446	14	19	10	14S
02442	15	19	10	15L
02447	16	21	10,5	16S
02444	18	23	10	18L

DADI DIN 3870

ECROUS DE SERRAGE
 NUTS DIN 3870
 ÜBERWURFMÜTTERN
 TUERCA DIN 3870

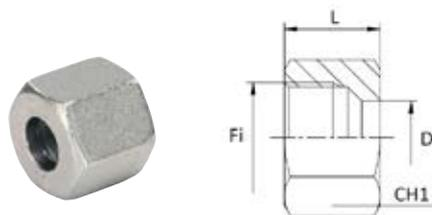

Art./Ref.	Filettatura interna/ Inner Thread	Ø interno mm/ Inside Ø mm	Lunghezza mm/ Length mm	CH1	Tipo/ Type
12293	12X1,5	6	14,5	14	6L
02421	14x1,5	8	14,5	17	8L
02420	16x1,5	10	15,5	19	10L
02424	18x1,5	12	15,5	22	12L
02418	20x1,5	12	17,5	24	12S
02425	22x1,5	14	20,5	27	14S
02426	22x1,5	15	17	27	15L
02427	24x1,5	16	20,5	30	16S
02433	26x1,5	18	18	32	18L

TAPPO PER TUBO

RACCORD EXTREMITÉ DROIT
PIPE PLUG
VERSCHLUSSTOPFEN
TAPON PARA MANGUERA

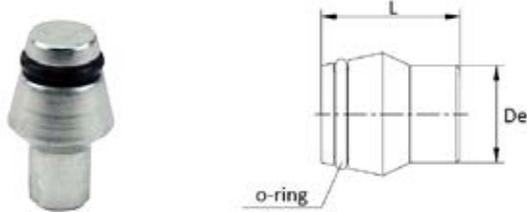

Art./Ref.	Ø esterno mm/ Outside Ø mm	Lunghezza mm/ Length mm
50139	6	17
50140	8	17
50141	10	20
50142	12	21
50143	15	21
50144	18	23

RACCORDO ESTREMITÀ DIRITTO

RACCORD EXTREMITÉ DROIT
STRAIGHT MALE COUPLING
GERADE-VERSCHRAUBUNGEN
RACOR INTERMEDIO

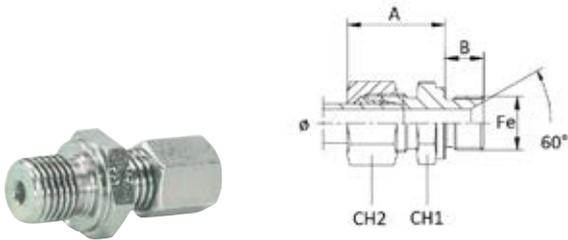

Art./Ref.	Filettatura esterna/ External Thread	Ø mm	A mm	B mm	CH1	CH2	Tipo/ Type
02584	1/4"	6	24,5	12	19	14	6L
02509	1/4"	8	25	12	19	17	8L
16497	3/8"	8	26,5	12	22	17	8L
16498	1/2"	8	27	14	27	17	8L
02521	1/4"	10	26	12	19	19	10L
02585	3/8"	10	27,5	12	22	19	10L
12611	1/2"	10	28	14	27	19	10L
12610	1/4"	12	26,5	12	19	22	12L
02522	3/8"	12	27	12	22	22	12L
02587	1/2"	12	27,5	14	27	22	12L
12612	3/8"	15	28,5	12	24	27	15L
02415	1/2"	15	29	14	27	27	15L
12295	1/2"	18	31	14	27	32	18L
02586	3/8"	14	36,5	12	24	27	14S
16500	3/8"	16	36,5	12	27	30	16S
02563	1/2"	16	37	14	27	30	16S
50127	18x1,5	12	27	12	24	22	12L

RACCORDO INTERMEDIO DIRITTO

UNION DOUBLE DROIT
STRAIGHT COUPLING
GERADE-VERSCHRAUBUNGEN
RACOR INTERMEDIO RECTO

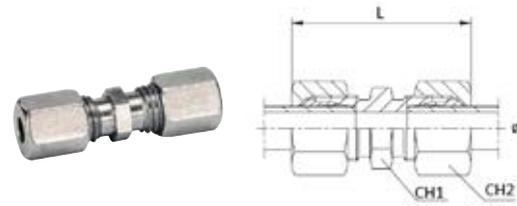

Art./Ref.	Ø mm	Lunghezza mm/ Length mm	CH1	CH2	Tipo/Type
02459	6	39	12	14	6L
02495	8	40	14	17	8L
02523	10	42	17	19	10L
02524	12	43	19	22	12L
02416	15	46	24	27	15L
16508	18	48	27	32	18L
02445	16	57	27	30	16S

RACCORDO INTERMEDIO DIRITTO CON O-RING

RACCORD INTERMEDIAIRE DROIT AVEC O-RING
STRAIGHT COUPLING WITH O-RING
GERADE VERBINDUNGEN
RACOR RECTO INTERMEDIO CON O-RING



Art./ Ref.	A mm	B mm	C mm	D mm	CH1	CH2	Lunghezza mm/ Length mm	Tipo/ Type
50091	8	8	14X1,5	14X1,5	17	17	40	8L
50092	10	10	16X1,5	16X1,5	19	19	40	10L
50093	12	12	18X1,5	18X1,5	22	22	40	12L
50094	15	15	22X1,5	22X1,5	27	27	44	15L

RACCORDO ESTREMITÀ A "L"

COUDE MALE A "L"

"L" END COUPLING

WINKEL VERSCHRAUBUNGEN

RACOR INTERMEDIO EN "L"



Art./Ref.	Filettatura esterna/ External Thread	Ø mm	A mm	B mm	C mm	D mm	CH1	CH2	Tipo/Type
02494	1/4"	8	29	14	12	26	12	17	8L
02519	1/4"	10	30	15	12	27	14	19	10L
02506	3/8"	10	34	17,5	12	28	17	22	10L
02520	3/8"	12	32	17	12	28	17	22	12L
02551	1/2"	12	34	20	14	34	19	22	12L
16505	3/8"	15	36	21	12	30	19	27	15L
02412	1/2"	15	36	21	14	34	19	27	15L
12296	1/2"	18	40	23,5	14	36	24	32	18L

RACCORDO INTERMEDIO A "L"

COUDE A "L"

"L" COUPLING

WINKEL-Verschraubungen

RACOR INTERMEDIO EN "L"

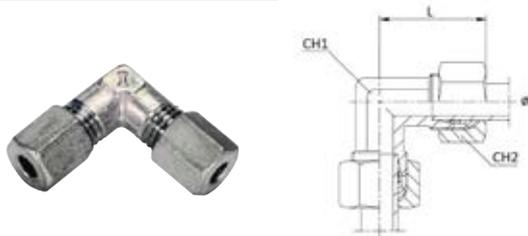

Art./Ref.	Ø mm	Lunghezza mm/Length mm	CH1	CH2	Tipo/Type
02496	8	29	12	17	8L
02517	10	30	14	19	10L
02518	12	32	17	22	12L
02417	15	36	19	27	15L
16512	18	40	24	32	18L

RACCORDO ORIENTABILE A GOMITO

COUDE ORIENTABILE

ANGULAR ROTARY FITTING

EINSTELLBARE WINKEL VERSCHRAUBUNGEN

RACOR PLEGADO ORIENTABLE

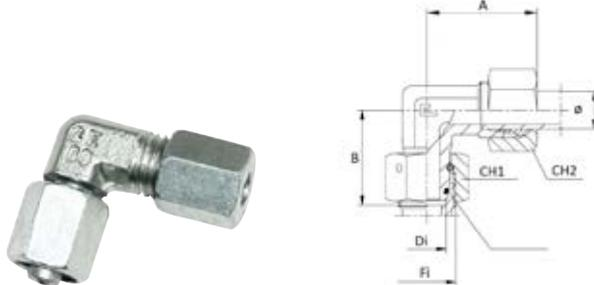

Art./Ref.	Filettatura interna/Inner Thread	Ø interno mm/Inside Ø mm	Ø mm	A mm	B mm	CH1	CH2	Tipo/Type
50097	14x1,5	8	8	29	27,5	17	17	8L
50098	16x1,5	10	10	30	29	19	19	10L
50099	18x1,5	12	12	32	29,5	22	22	12L
50100	22x1,5	15	15	36	32,5	27	27	15L

RACCORDO INTERMEDIO A "T"

COUDE A "T"

"T" COUPLING

WINKEL-Verschraubungen

RACOR INTERMEDIO EN "T"

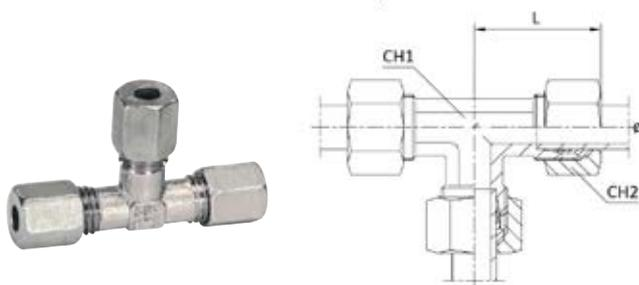

Art./Ref.	Ø mm	Lunghezza mm/Length mm	CH1	CH2	Tipo/Type
02455	6	27	12	14	6L
02525	8	29	12	17	8L
02526	10	30	14	19	10L
02527	12	32	17	22	12L
02419	15	36	19	27	15L
16518	18	40	24	32	18L
16522	14	40	19	27	14S

RACCORDO ORIENTABILE A "T"

COUDE A "T"
"T" COUPLING
EINSTELLBARE T VERSCHRAUBUNGEN
RACOR ORIENTABLE EN "T"

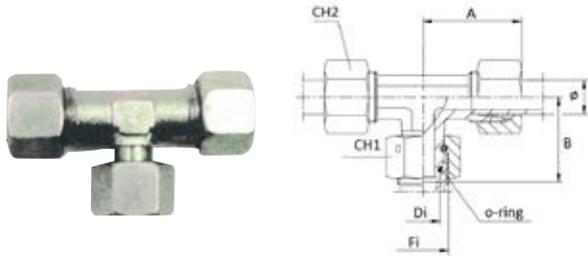

Art./Ref.	Filettatura interna/ Inner Thread	Ø interno mm/ Inside Ø mm	Ø mm	A mm	B mm	CH1	CH2	Tipo/ Type
50103	14x1,5	8	8	29	27,5	17	17	8L
50104	16x1,5	10	10	30	29	19	19	10L
50105	18x1,5	12	12	32	29,5	22	22	12L
50106	22x1,5	15	15	36	32,5	27	27	15L

RACCORDO ORIENTABILE A "T"

COUDE A "T"
"T" COUPLING
EINSTELLBARE T VERSCHRAUBUNGEN
RACOR ORIENTABLE EN "T"

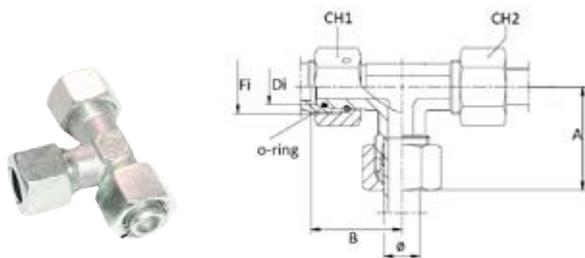

Art./Ref.	Filettatura interna/ Inner Thread	Ø interno mm/ Inside Ø mm	Ø mm	A mm	B mm	CH1	CH2	Tipo/ Type
50110	16x1,5	10	10	30	29	19	19	10L
50111	18x1,5	12	12	32	29,5	22	22	12L
50112	22x1,5	15	15	36	32,5	27	27	15L

RACCORDO INTERMEDIO A CROCE

CROIX EGAL
CROSS COUPLING
KREUZ-VERSCHRAUBENGEN
RACOR INTERMEDIO EN CRUZ

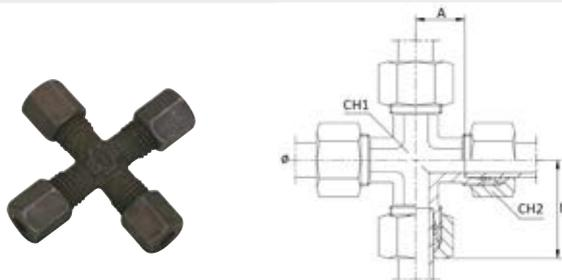

Art./Ref.	Ø mm	A mm	B mm	CH1	CH2	Tipo/Type
09211	8	14	29	12	17	8L

RACCORDO DIRITTO PREMONTATO

RACCORD DROIT PRE-MONTÉ
STRAIGHT PRE-MOUNTED FITTING
ANSCHLUSS GARADE VORMONFIERT
RACOR RECTO PREMONTADO

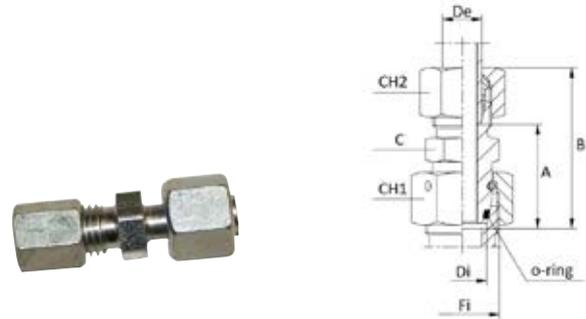

Art./Ref.	Ø interno mm/ Inside Ø mm	Filettatura interna/ Inner Thread	Ø esterno mm/ Outside Ø mm	A mm	B mm	C mm	CH1	CH2	Tipo/ Type
50083	8	14X1,5	6	24	39	12	17	14	8L-6L
50085	12	18X1,5	8	25,5	40,5	17	22	17	12L-8L
50086	12	18X1,5	10	26,5	41,5	17	22	19	12L-10L

RACCORDO ORIENTABILE

EQUERRE ORIENTABLE ARTICULEE BANJOS
SWIABLE COUPLING
DROSSELFREIE SCHWENKVERSCHRAUBUNGEN
RACOR ORIENTABLE

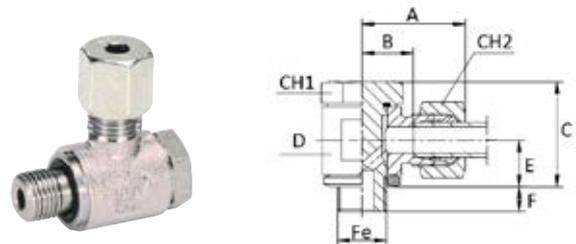

Art./Ref.	Filettatura esterna/ External Thread	A mm	B mm	C mm	D mm	E mm	F mm	CH1	CH2	Tipo/ Type
09207	1/4"	29,5	14,5	32	22	14	12	19	17	8L
09208	1/4"	30,5	15,5	32	22	14	12	19	19	10L
09320	3/8"	35	18,5	38,5	27	16,5	12	24	22	10L
09209	3/8"	33	18	38,5	27	16,5	12	24	22	12L
09210	1/2"	37	22	46,5	32	21,5	14	30	27	15L
50116	18x1,5	38	21,5	42	32	18,5	12	27	24	12L

OCCHIO CON OGIVA PER APPLICAZIONE SUI TUBI BONDERIZZATI

BANJO AVEC BAGUE POUR TUBES BONDERISES
 EYE WITH NUTS FOR BONDERIZED PIPES
 RINGÖSE MIT SCHNEIDRING FÜR STAHLRÖHRE
 ORIENTABLE PARA TUBO RIGIDO

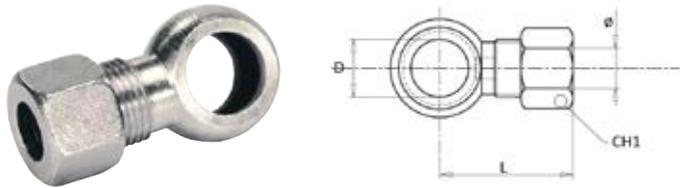

Art./Ref.	D mm	Ø mm	Lunghezza mm/ Lenght mm	CH1
12565	1/4"	12L	43,5	22
02510	3/8"	12L	38,5	22
02511	1/2"	15L	44,5	27

OCCHIO CORTO

BANJO COURT
 SHORT EYE CONNECTION
 RINGÖSE KURZ
 ORIENTABLE CORTO

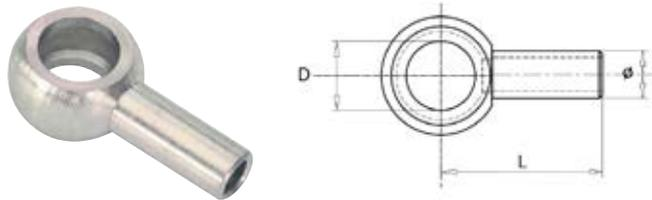

Art./Ref.	D mm	Ø mm	Lunghezza mm/ Lenght mm
12566	1/4"	12L	38
02487	3/8"	12L	40
02488	1/2"	15L	44

OCCHIO LUNGO

BAJO LONG
 LONG EYE CONNECTION
 RINGÖSE LANG
 OJO LARGO

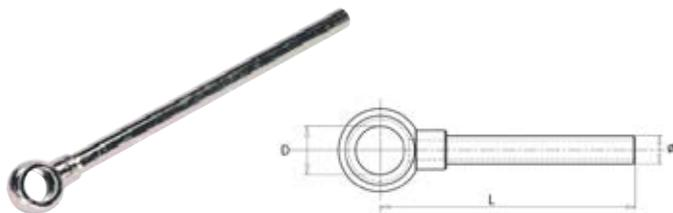

Art./Ref.	D mm	Ø mm	Lunghezza mm/ Lenght mm
12567	1/4"	12L	205
10999	3/8"	12L	199
11000	1/2"	15L	202

OCCHIO MEDIO

BANJO MOYEN
 MEDIUM EYE CONNECTION
 RINGÖSE MITTEL
 OJO MEDIO

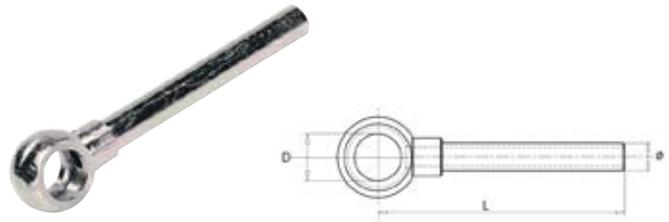

Art./Ref.	D mm	Ø mm	Lunghezza mm/ Lenght mm
10997	3/8"	12L	106
10998	1/2"	15L	109

1.2.3 Macchine per la lavorazione del tubo oleodinamico

Machine for hydraulic hoses



Ricambi & accessori per macchine agricole

SPARE PARTS & ACCESSORIES FOR AGRICULTURAL MACHINE

Tutti gli articoli della presente sezione, prodotti da AMA SPA e/o da terzi per conto di AMA, sono adattabili ("non originali") alle marche indicate ai sensi di quanto previsto dal REG. CE n. 1400/2002. I diritti sui marchi citati appartengono ai legittimi proprietari ed il loro uso ha l'esclusiva finalità di consentire all'utilizzatore la comparazione dei diversi prodotti. All items of this section, manufactured by AMA SPA and/or any third party on behalf of AMA, are adaptable ("non-original") to the brands listed under the provisions of the REG. CE n. 1400/2002. The rights on the trademarks belong to their respective owners and their usage is only aimed to allow the user to compare different products.

ART. 00553
PRESSATUBI SEMIAUTOMATICA 1"

MACHINE A SERTIR SEMI-AUTOMATIQUE 1"
 1" SEMI-AUTOMATIC CRIMPING MACHINE
 1" HALBAUTOMATISCHE SCHLAUCHPRESSE
 PRESANDORA SEMIAUTOMATICA 1"

Dati tecnici:

Pressa Semiautomatica, per pressare tubi flessibili oleodinamici trecciati e spiralati fino ad 1"R2 adatta a pressare qualsiasi tipo di raccordi.
 Potenza di pressatura 30ton, pressione 180 bar.
 Morsetti in dotazione (13,19,25,32,38).
 Peso 55 kg. Dimensioni 550Hx190x250

Technical data: *Crimping machine for hydraulic hose steel braid until 1" R2.*

*Oresing force 30ton, working pressure 180 bar, dies together the machine (13,19,25,32,38).
 Weight 55 Kg dimensions 550x190x250.*

Art./Ref.	Descrizione/Description	Note/Note	Brand	Applicazione/ Application
00553	TUBOPRESS 1"R2	-	-	-
16142	MORSETTI ø 10/DIES ø 10	OPTIONAL	A.M.A.	00553
16143	MORSETTI ø 13/DIES ø 13	-	A.M.A.	00553
16144	MORSETTI ø 16/DIES ø 16	OPTIONAL	A.M.A.	00553
16145	MORSETTI ø 19/DIES ø 19	-	A.M.A.	00553
16146	MORSETTI ø 25/DIES ø 25	-	A.M.A.	00553
16147	MORSETTI ø 32/DIES ø 32	-	A.M.A.	00553
16148	MORSETTI ø 38/DIES ø 38	-	A.M.A.	00553
16168	DISTRIBUTORE/SPOOL VALVE	-	A.M.A.	00553
16157	KIT GUARNIZIONI/SEALS KIT	-	A.M.A.	00553
16170	MICROMETRO/MICROMETER	-	A.M.A.	00553
16171	TUBO OLI/OIL TUBE	-	A.M.A.	00553
16172	KIT STAFFE/BRACKETS	-	A.M.A.	00553
16173	KIT TIRANTI/TIE ROD KIT	-	A.M.A.	00553
16174	KIT MOLLE/SPRING KIT	-	A.M.A.	00553
16175	CASTELLO CPL/DIES HOLDER	-	A.M.A.	00553
16176	PIASTRA CONICA/CONICAL PLATE	-	A.M.A.	00553
16177	PIASTRA PORTAMICROMETRO/ MICROMETER HOLDING PLATE	-	A.M.A.	00553

ART. 00752
PRESSATUBI SEMIAUTOMATICA 1" 1/2

MACHINE A SERTIR SEMI-AUTOMATIQUE 1" 1/2
 1" 1/2 SEMI-AUTOMATIC HYDRAULIC HOSES PRESSING IMPLEMENT
 1" 1/2 HALBAUTOMATISCHE SCHLAUCHPRESSE
 PRESANDORA SEMIAUTOMATICA

Dati tecnici:

Pressa Semiautomatica, per pressare tubi flessibili oleodinamici trecciati e spiralati fino ad 1"1/2" adatta a pressare qualsiasi tipo di raccordi.
 Potenza di pressatura 40ton, pressione 180 bar.
 Morsetti in dotazione (16-19,5-25-29,5-38-46-52,5)
 Dimensioni 740Hx250x350

Technical data:

Crimping machine for hydraulic hose steel braid until 1" 1/2" R2. oresing force 40ton, working pressure 180 bar, dies together the machine (16,19,5,25, 29,5,38, 46, 52,5). Weight 75 Kg dimensions 740x250x350

Art./Ref.	Descrizione/Description	Note/Note	Brand	Applicazione/ Application
00752	TUBOPRESS 1"1/2" R2	-	-	-
16149	MORSETTI ø 13/DIES ø 13	OPTIONAL	A.M.A.	00752
16150	MORSETTI ø 16/DIES ø 16	-	A.M.A.	00752
16151	MORSETTI ø 19,5/DIES ø 19,5	-	A.M.A.	00752
16152	MORSETTI ø 25/DIES ø 25	-	A.M.A.	00752
16154	MORSETTI ø 38/DIES ø 38	-	A.M.A.	00752
16155	MORSETTI ø 46/DIES ø 46	-	A.M.A.	00752
16156	MORSETTI ø 52,5/DIES ø 52,5	-	A.M.A.	00752
16158	KIT GUARNIZIONI/SEALS KIT	-	A.M.A.	00752
16178	MICROMETRO/MICROMETER	-	A.M.A.	00752
16179	TUBO OLIO/OIL TUBE	-	A.M.A.	00752
16180	KIT STAFFE/KIT STAFFE	-	A.M.A.	00752
16181	KIT TIRANTI/TIE ROD KIT	-	A.M.A.	00752
16182	KIT MOLLE/SPRING KIT	-	A.M.A.	00752
16183	CASTELLO CPL/DIES HOLDER	-	A.M.A.	00752
16184	PIASTRA CONICA/CONICAL PLATE	-	A.M.A.	00752
16185	PIASTRA PORTAMICROMETRO/ MICROMETER HOLDING PLATE	-	A.M.A.	00752

ART. 81170
PRESSATUBI AUTOMATICA CON CONTROLLO ELETTRICO "TUBOMATIC H130ES"
 SERTISSEUSE AVEC CONTROLE ELECTRONIQUE "TUBOMATIC H130ES"
 CRIMPING MACHINE WITH ELECTRONIC CONTROL "TUBOMATIC H130ES"
 SCHLAUCHPRESSE MIT ELEKTRONISCHER KONTROLLE "TUBOMATIC H130ES"
 HERRAMIENTAS "TUBOMATIC H130ES"



Art. 81172



ART. 57393

Note: I MORSETTI NON SONO COMPRESI

Forza di pressatura 190 TON
 Capacita' su tubo 6 spirali 1" 1/4
 Capacita' su tubo 4 spirali 2"
 Tubo industriale 3"
 Raccordi 90° 2"
 Ø Massimo di pressatura 130 mm*
 Apertura morsetti Ø + 35 mm
 Voltaggio standard 375V-420V 50HZ 3PH
 Potenza del motore 4 KW
 Dimensioni l x p x h 760x690x730 mm
 Peso con olio 360 KG
 Fine corsa elettrico incl.
 Cilindro doppio effetto incl.
 Olio 97 lt.
 Dispenser + cambio rapido ARTICOLO AMA 81172
 Pedale elettrico ARTICOLO AMA 57393
 Morsetti per marcatura OPTIONAL
 Morsetti speciali OPTIONAL

Notes: DIES NOT INCLUDED

Swaging force 190 TON
 6 Spirals 1"1/4
 4 Spirals 2"
 Industrial hose 3"
 Maximum crimping Ø 130 mm*
 Dies opening Ø + 35 mm
 Fittings 90° 2"
 Standard voltage 375V-420V 50HZ 3PH
 Motor power 4 KW
 Dimensions l x d x h 760x690x730 mm
 Weight without oil 360 KG
 Oil 97 lt
 Electric limit switch incl.
 Double acting cylinder incl.
 Dispenser + quick change AMA CODE 81172
 Electric pedal AMA CODE 57393
 Marking dies OPTIONAL
 Special dies OPTIONAL

Art./Ref.	Descrizione/Description
81170	TUBOMATIC H130ES
81172	BASE E DISPENSER + CAMBIO RAPIDO MORSETTI/BASE + QUICK CHANGE DIE SYSTEM
57393	PEDALE/ELECTRIC PEDAL
81173	MORSETTI Ø 10/DIES Ø 10
81774	MORSETTI Ø 12/DIES Ø 12
81175	MORSETTI Ø 14/DIES Ø 14
81176	MORSETTI Ø 16/DIES Ø 16
81177	MORSETTI Ø 19/DIES Ø 19
81178	MORSETTI Ø 22/DIES Ø 22
81179	MORSETTI Ø 25/DIES Ø 25
81180	MORSETTI Ø 29/DIES Ø 29
81181	MORSETTI Ø 34/DIES Ø 34
81182	MORSETTI Ø 38/DIES Ø 38
81183	MORSETTI Ø 42/DIES Ø 42
81184	MORSETTI Ø 46/DIES Ø 46
81185	MORSETTI Ø 50/DIES Ø 50
81186	MORSETTI Ø 54/DIES Ø 54
81187	MORSETTI Ø 58/DIES Ø 58
81188	MORSETTI Ø 63/DIES Ø 63
81189	MORSETTI Ø 66/DIES Ø 66
81190	MORSETTI Ø 69/DIES Ø 69
81191	MORSETTI Ø 71/DIES Ø 71

ART.81171
PRESSATUBI AUTOMATICA CON CONTROLLO ELETTRICO "TUBOMATIC H130EL"
SERTISSEUSE AVEC CONTROLE ELECTRONIQUE "TUBOMATIC H130EL"
CRIMPING MACHINE WITH ELECTRONIC CONTROL "TUBOMATIC H130EL"
SCHLAUCHPRESSE MIT ELEKTRONISCHER KONTROLLE "TUBOMATIC H130EL"
HERRAMIENTAS "TUBOMATIC H130EL"

Art. 81172

Note: I MORSETTI NON SONO COMPRESI

Forza di pressatura 190 TON

Capacità su tubo 6 spirali 1" 1/4

Capacità su tubo 4 spirali 2"

Tubo industriale 3"

Raccordi 90° 2"

Ø Massimo di pressatura 130 mm*

Apertura morsetti Ø + 35 mm

Voltaggio standard 375V-420V 50HZ 3PH

Potenza del motore 4 KW

Dimensioni l x p x h 760x690x730 mm

Peso con olio 360 KG

Fine corsa elettrico incl.

Cilindro doppio effetto incl.

Olio 97 lt.

Dispenser + cambio rapido ARTICOLO AMA 81172

Morsetti per marcatura OPTIONAL

Morsetti speciali OPTIONAL

Notes: DIES NOT INCLUDED

Swaging force 190 TON
6 Spirals 1"1/4
4 Spirals 2"
Industrial hose 3"
*Maximum crimping Ø 130 mm**
Dies opening Ø + 35 mm
Fittings 90° 2"
Standard voltage 375V-420V 50HZ 3PH
Motor power 4 KW
Dimensions l x d x h 760x690x730 mm
Weight without oil 360 KG
Oil 97 lt
Electric limit switch incl.
Double acting cylinder incl.
Dispenser + quick change AMA CODE 81172
Electric pedal AMA CODE 57393
Marking dies OPTIONAL
Special dies OPTIONAL

Art./Ref.	Descrizione/Description
81171	TUBOMATIC H130EL
81172	BASE E DISPENSER + CAMBIO RAPIDO MORSETTI/ BASE + QUICK CHANGE DIE SYSTEM
57393	PEDALE/ELECTRIC PEDAL
81173	MORSETTI Ø 10/DIES Ø 10
81774	MORSETTI Ø 12/DIES Ø 12
81175	MORSETTI Ø 14/DIES Ø 14
81176	MORSETTI Ø 16/DIES Ø 16
81177	MORSETTI Ø 19/DIES Ø 19
81178	MORSETTI Ø 22/DIES Ø 22
81179	MORSETTI Ø 25/DIES Ø 25
81180	MORSETTI Ø 29/DIES Ø 29
81181	MORSETTI Ø 34/DIES Ø 34
81182	MORSETTI Ø 38/DIES Ø 38
81183	MORSETTI Ø 42/DIES Ø 42
81184	MORSETTI Ø 46/DIES Ø 46
81185	MORSETTI Ø 50/DIES Ø 50
81186	MORSETTI Ø 54/DIES Ø 54
81187	MORSETTI Ø 58/DIES Ø 58
81188	MORSETTI Ø 63/DIES Ø 63
81189	MORSETTI Ø 66/DIES Ø 66
81190	MORSETTI Ø 69/DIES Ø 69
81191	MORSETTI Ø 71/DIES Ø 71

ART.83972
PRESSATUBI AUTOMATICA CON CONTROLLO ELETTRONICO "TUBOMATIC H88ES"

SERTISSEUSE AVEC CONTROLE ELECTRONIQUE "TUBOMATIC H88ES"
 CRIMPING MACHINE WITH ELECTRONIC CONTROL "TUBOMATIC H88ES"
 SCHLAUCHPRESSE MIT ELEKTRONISCHER KONTROLLE "TUBOMATIC H88ES"
 HERRAMIENTAS "TUBOMATIC H88ES"

Note: I MORSETTI NON SONO INCLUSI

Forza di pressatura 135 tons(150 us tons)
 6 Spirali 2 pezzi 1"
 4 Spirali 1" 1/2"
 Ø Massimo 88 mm* (3.464") pressature/ora 680
 Apertura dei morsetti ø + 48 mm (ø + 1.890")
 Raccordi 90° 1" 1/4
 Voltaggio standard 375v-420v-50hz-3ph
 Potenza del motore 4 kw (5 hp)
 Dimensioni l x p x h 700x613x640 mm (31.890"x24.803"x33.386")
 Peso senza olio 161 kg (355 lbs)
 Olio 70 lt.
 Cilindro doppio effetto incl.
 Pinza cambio rapido ARTICOLO AMA 91004
 Dispenser ARTICOLO AMA 91005
 Pedale elettrico ARTICOLO AMA 57393
 Morsetti per marcatura OPTIONAL
 Morsetti speciali OPTIONAL

Notes: DIES NOT INCLUDED

Swaging force 135 tons(150 us tons)
 6 Wire spiral 2 pieces 1"
 4 Wire spiral 1" 1/2"
 Maximum ø 88 mm* (3.464") swaging/hour 680
 Die opening ø + 48 mm (ø + 1.890")
 90° Fittings 1" 1/4
 Standard voltage 375v-420v-50hz-3ph
 Motor power 4 kw (5 hp)
 Dimensions l x w x h 700x613x640 mm (31.890"x24.803"x33.386")
 Weight without oil 161 kg (355 lbs)
 Oil 70 lt.
 Double acting cylinder incl.
 Quick change ama code 91004
 Dispenser ama code 91005
 Marking dies optional
 Special dies optional



ART. 57393

Art./Ref.	Descrizione/Description
83972	TUBOMATIC H88ES
91004	PINZA CAMBIO RAPIDO X H88/QUICK CHANGE TOOL FOR H88
91005	DISPENSER PORTAMORSETTI X H88/DIES HOLDER DISPENSER FOR H88
57393	PEDALE/ELECTRIC PEDAL
83976	MORSETTI ø 10/MORSETTI ø 10/ DIES ø 10
83977	MORSETTI ø 12/DIES ø 12
83978	MORSETTI ø 14/DIES ø 14
83979	MORSETTI ø 16/DIES ø 16
83980	MORSETTI ø 19/DIES ø 19
83981	MORSETTI ø 22/DIES ø 22
83982	MORSETTI ø 25/DIES ø 25
83983	MORSETTI ø 29/DIES ø 29
83984	MORSETTI ø 34/DIES ø 34
83985	MORSETTI ø 38/DIES ø 38
83986	MORSETTI ø 42/DIES ø 42
83987	MORSETTI ø 46/DIES ø 46

ART.83973
PRESSATUBI AUTOMATICA CON CONTROLLO ELETTRONICO "TUBOMATIC H88EL"

SERTISSEUSE ELECTROMECHANIQUE "TUBOMATIC H88EL"
 ELECTROMECHANIC CRIMPING MACHINE "TUBOMATIC H88EL"
 ELEKTROMECHANISCHE SCHLAUCHPRESSE "TUBOMATIC H88EL"
 HERRAMIENTAS "TUBOMATIC H88EL"

Note: I MORSETTI NON SONO INCLUSI

Forza di pressatura 135 TONS(150 US TONS)
 6 Spirali 2 pezzi 1"
 4 Spirali 1" 1/2"
 Ø Massimo 88 mm* (3.464") PRESSATURE/ORO 680
 Apertura dei morsetti Ø + 48 mm (Ø + 1.890")
 Raccordi 90° 1" 1/4
 Voltaggio standard 375V-420V-50HZ-3PH
 Potenza del motore 4 Kw (5 Hp)
 Dimensioni L x P x H 700x613x640 mm (31.890"x24.803"x33.386")
 Peso senza olio 161 Kg (355 lbs)
 Olio 70 lt.
 Cilindro doppio effetto incl.
 Pinza cambio rapido ARTICOLO AMA 91004
 Dispenser ARTICOLO AMA 91005
 Pedale elettrico ARTICOLO AMA 57393
 Morsetti per marcatura OPTIONAL
 Morsetti speciali OPTIONAL

Notes: DIES NOT INCLUDED

Swaging force 135 tons(150 us tons)
 6 Wire spiral 2 pieces 1"
 4 Wire spiral 1" 1/2"
 Maximum ø 88 mm* (3.464") Swaging/hour 680
 Die opening ø + 48 mm (ø + 1.890")
 90° Fittings 1" 1/4
 Standard voltage 375v-420v-50hz-3ph
 Motor power 4 kw (5 hp)
 Dimensions l x w x h 700x613x640 mm (31.890"x24.803"x33.386")
 Weight without oil 161 kg (355 lbs)
 Oil 70 lt.
 Double acting cylinder incl.
 Quick change ama code 91004
 Dispenser ama code 91005
 Marking dies optional
 Special dies optional



ART. 57393

Art./Ref.	Descrizione/Description
83973	TUBOMATIC H88EL
91004	PINZA CAMBIO RAPIDO X H88/QUICK CHANGE TOOL FOR H88
91005	DISPENSER PORTAMORSETTI X H88/DIES HOLDER DISPENSER FOR H88
57393	PEDALE/ELECTRIC PEDAL
83976	MORSETTI ø 10/DIES ø 10
83977	MORSETTI ø 12/DIES ø 12
83978	MORSETTI ø 14/DIES ø 14
83979	MORSETTI ø 16/DIES ø 16
83980	MORSETTI ø 19/DIES ø 19
83981	MORSETTI ø 22/DIES ø 22
83982	MORSETTI ø 25/DIES ø 25
83983	MORSETTI ø 29/DIES ø 29
83984	MORSETTI ø 34/DIES ø 34
83985	MORSETTI ø 38/DIES ø 38
83986	MORSETTI ø 42/DIES ø 42
83987	MORSETTI ø 46/DIES ø 46

ART.80649
PRESSATUBI MANUALE "TUBOMATIC H47PM"
OUTILS "TUBOMATIC H47PM"
TOOLS "TUBOMATIC H47PM"
WERKZEUGE "TUBOMATIC H47PM"
HERRAMIENTAS "TUBOMATIC H47PM"

Note: I MORSETTI NON SONO COMPRESI

Forza di pressatura 100 TON

Capacità su tubo 2 spirali 1"

Raccordi 90° 3/8"

Ø Massimo di pressatura 46 mm*

Apertura morsetti Ø + 20 mm

Dimensioni l x p x h 300x390x280 mm

Peso con olio 32 KG

Cilindro singolo effetto incl.

Sforzo sulla leva 30 KG

Cassetto porta morsetti incl.

Olio incl.

Morsetti speciali OPTIONAL

Utensile cambio morsetti OPTIONAL

Notes: DIES NOT INCLUDED
Swaging force 100 TON
Capacity 1"
90° Fitting 3/8"
*Maximum crimping Ø 46 mm**
Dies opening Ø + 20 mm
Dimensions L x W x H 300x390x280 mm
Weight 32 KG
One acting cylinder incl.
Effort on lever 30 KG
Dies holder drawer incl.
Oil incl
Special dies OPTIONAL
Tool for dies change OPTIONAL

Art./Ref.	Descrizione/Description
80649	TUBOMATIC H47PM
80650	MORSETTI Ø 10/DIES Ø 10
80651	MORSETTI Ø 12/DIES Ø 12
80652	MORSETTI Ø 14/DIES Ø 14
80653	MORSETTI Ø 16/DIES Ø 16
80654	MORSETTI Ø 19/DIES Ø 19
80655	MORSETTI Ø 22/DIES Ø 22
80656	MORSETTI Ø 25/DIES Ø 25
80657	MORSETTI Ø 29/DIES Ø 29

ART. 84667
TAGLIERINA MODELLO TF1 ECO
TRONCONNEUSE TF1
CUTTING MACHINE TF1 ECO
SCHLAUCH-TRENNMASCHINE TF1
MAQUINA DE CORTE TF1

Note: capacità su tubo 4 spirali 1"

Capacità su tubo 2 trecce 1"

Ø Massimo di taglio 45 mm (1.771")

Giri al minuto 2900

Ø Lama 250 mm (9.843")

Peso 28 Kg (62 lbs)

Dimensioni L x P x H 515x580x355 mm (20.275"x22.835"x13.976")

Voltaggio standard 400V 3PH 50HZ

Potenza del motore 0.75 Kw (1 Hp)

Notes: capacity on 4 spirals hose 1"

Capacity on 2 steel braid 1"
Maximum cutting Ø 45 mm (1.771")
Speed / minutes 2900 rpm
Blade Ø 250 mm (9.843")
Weight 28 Kg (62 lbs)
Dimension L x P x H 515x580x355 mm (20.275"x22.835"x13.976")
Standard voltage 400V 3PH 50HZ
Power 0.75 Kw (1 Hp)

Art./Ref.	Descrizione/Description
84667	TAGLIERINA TF1/CUTTING MACHINE TF1

ART.57466
TAGLIERINA "MODELLO TF2"
REGLE DE MESURE
CUTTING MACHINE "TF2"
SCHLAUCH-TRENNMASCHINE "TF2"
MAQUINA DE CORTE "TF2"

Note: capacità su tubo 6 spirali 1" 1/2

Capacità su tubo 2 trecce 2"

Ø Massimo di taglio 75 mm

Giri al minuto 2900

Ø Lama 250 mm

Peso 130 KG

Dimensioni l x p x h 800x550x1150 mm

Voltaggio standard 400V 50HZ3PH

Potenza del motore 3 KW

Raccordo aspirazione incl.

Protezione di sicurezza incl.

Notes: capacity on 6 spirals hose 1" 1/2

Capacity on 2 spirals hose 2"
Maximum cutting Ø 75 mm
Revolutions/minute 2900
Blade Ø 250 mm
Weight 130 KG
Dimensions l x d x h 800x550x1150 mm
Standard voltage 400V 50HZ3PH
Motor power 3 KW
Suction connection incl.
Safety protection incl.

Art./Ref.	Descrizione/Description
57466	TAGLIERINA TF2/CUTTING MACHINE TF2
57467	CANALINA PORTATUBO /MEASURING HOSE HOLDER

ART.57468
SPELLATUBI "MODELLO SPF2/E"

DENUDEUSE "SPF2/E"
SKIVING MACHINE "SPF2/E"
SCHALMASCHINE "SPF2/E"
MAQUINA DE PELADO "SPF2/E"



Note: capacita' Ø esterno 2"
Capacita' Ø interno 2"
Giri al minuto 300
Peso 44 KG
Dimensioni l x p x h 640x520x360 mm
Voltaggio standard 400V 50HZ 3PH
Potenza del motore 0.75 KW
Protezione di sicurezza incl.
Pedale elettrico incl.
Portautensili optional

Notes: external skiving 2"
Internal skiving 2"
Revolutions/minute 300
Weight 44 KG
Dimensions l x d x h 640x520x360 mm
Standard voltage 400V 50HZ 3PH
Motor power 0.75 KW
Safety protection incl.
Electric pedal incl.
Tools holder optional

Art./Ref.	Descrizione/Description
57468	SPELLATUBI SPF2/SKIVING MACHINE SPF2
57470	PERNO PER PELATURA ESTERNA DA 3/16"/EXTERNAL TOOL 3/16"
57471	PERNO PER PELATURA ESTERNA DA 1/4"/EXTERNAL TOOL 1/4"
57472	PERNO PER PELATURA ESTERNA DA 5/16"/EXTERNAL TOOL 5/16"
57473	PERNO PER PELATURA ESTERNA DA 3/8"/EXTERNAL TOOL 3/8"
57474	PERNO PER PELATURA ESTERNA DA 1/2"/EXTERNAL TOOL 1/2"
57475	PERNO PER PELATURA ESTERNA DA 5/8"/EXTERNAL TOOL 5/8"
57476	PERNO PER PELATURA ESTERNA DA 3/4"/EXTERNAL TOOL 3/4"
57477	PERNO PER PELATURA ESTERNA DA 1"/EXTERNAL TOOL 1"
57478	PERNO PER PELATURA ESTERNA DA 1"1/4"/EXTERNAL TOOL 1"1/4"
57479	PERNO PER PELATURA ESTERNA DA 1"1/2"/EXTERNAL TOOL 1"1/2"
57480	PERNO PER PELATURA ESTERNA DA 2"/EXTERNAL TOOL 2"
57482	PERNO PER PELATURA INTERNA DA 1/2"/INTERNAL TOOL 1/2"
57483	PERNO PER PELATURA INTERNA DA 5/8"/INTERNAL TOOL 5/8"
57484	PERNO PER PELATURA INTERNA DA 3/4"/INTERNAL TOOL 3/4"
57485	PERNO PER PELATURA INTERNA DA 1"/INTERNAL TOOL 1"
57620	PERNO PER PELATURA INTERNA DA 1"1/4"/INTERNAL TOOL 1"1/4"
57487	PERNO PER PELATURA INTERNA DA 1"1/2"/INTERNAL TOOL 1"1/2"
57488	PERNO PER PELATURA INTERNA DA 2"/INTERNAL TOOL 2"

CENTRALINA DI COMANDO PER PRESSE OLEODINAMICHE

GRUPE D'ALIMENTATION POUR PRESSES A SERTIR
ELECTRIC POWER PACK FOR HOSE FITTING MACHINE
HYDRO-AGGREGAT FÜR SCHLAUCHPRESSE
CENTRAL ALIMENTACIÓN DE PRESIÓN OLEODINAMICA



Note:
Potenza motore 2,2Kw
Serbatoio 15 lt
Portata pompa 6 litri/minuto
Pressione max 160 bar

Notes:
Engineering power 2,2Kw
Tank 15 liters
Max flow 6 lt/min.
Max pressure 160 bar

Art./Ref.	Volt/Volt	Potenza Motore/Engine power
03878	220V	2.2
03898	380V	2.2

SROTOLATORE 6 POSTI

ENROULEUR
HOSE ROLLER 6 PLACES
SCHLAUCHHASPEL
DEVANADORA DE TUBO



Art./Ref.	Note/Notes
83880	SROTOLATORE A 6 POSTI/HOSE ROLLER 6 PLACES

MINICENTRALINA

MINIGROUPE D'ALIMENTATION
 POWER PACK UNIT
 HYDRO-AGGREGAT
 MINICENTRAL ALIMENTACION

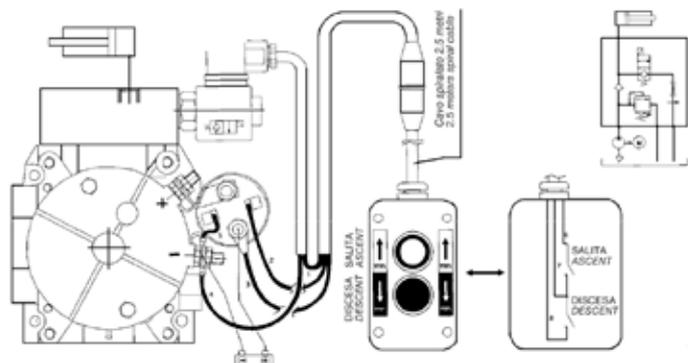
Note:

Motore: 12V/1600W + relè
 Serbatoio 5 lt.
 Portata pompa 3,2 cm³/g
 Pressione max. 250 BAR.
 Solenoide: 12 VDC
 Valvola elettrica normalmente chiusa.

Notes: Features:

Engine: 12V/1600 W
 Tank: 5 liters.
 Pump capacity: 3,2 cm³/g
 Max pressure 250 bar
 Bucking coil 12 VDC
 Electric valve normally closed

Art./Ref.	Descrizione/Description
17081	Minicentralina in corrente continua/DC mini powerpack

PULSANTIERA PER MINICENTRALINA IN CORRENTE CONTINUA

TABLEAUX POUR GROUPE D'ALIMENTATION
 PUSH BOTTON FOR MINI POWERPACK
 KABEL FERNSTEUERUNG FUER HYDRO-AGGREGAT
 PULSADOR PARA CENTRAL D'ALIMENTACION

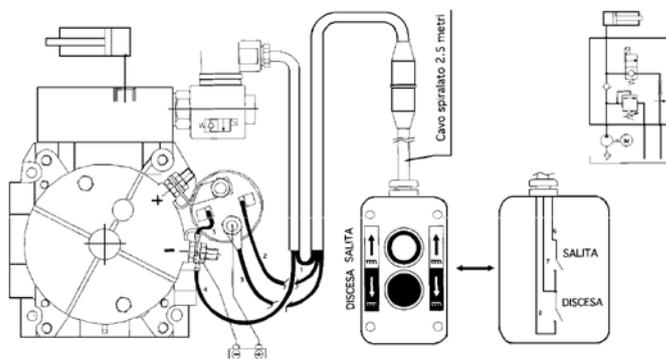

Art./Ref.	Note/Note
75874	17081

1.2.4 Pompe oleodinamiche ad ingranaggi & accessori

Hydraulic gear cuheel & accessories



Ricambi & accessori per macchine agricole

SPARE PARTS & ACCESSORIES FOR AGRICULTURAL MACHINE

Tutti gli articoli della presente sezione, prodotti da AMA SPA e/o da terzi per conto di AMA, sono adattabili ("non originali") alle marche indicate ai sensi di quanto previsto dal REG. CE n. 1400/2002. I diritti sui marchi citati appartengono ai legittimi proprietari ed il loro uso ha l'esclusiva finalità di consentire all'utilizzatore la comparazione dei diversi prodotti. All items of this section, manufactured by AMA SPA and/or any third party on behalf of AMA, are adaptable ("non-original") to the brands listed under the provisions of the REG. CE n. 1400/2002. The rights on the trademarks belong to their respective owners and their usage is only aimed to allow the user to compare different products.

POMPE AD INGRANAGGI GRUPPO 1 MADE IN ITALY

POMPES A ENGRENAGES GROUPE 1 «MADE IN ITALY»

GEAR PUMPS GROUP 1 "MADE IN ITALY"

ZAHNRADPUMPEN GRUPPE 1 „MADE IN ITALY“

BOMBA CON ENGRANAJE GRUPO 1 "MADE IN ITALY"

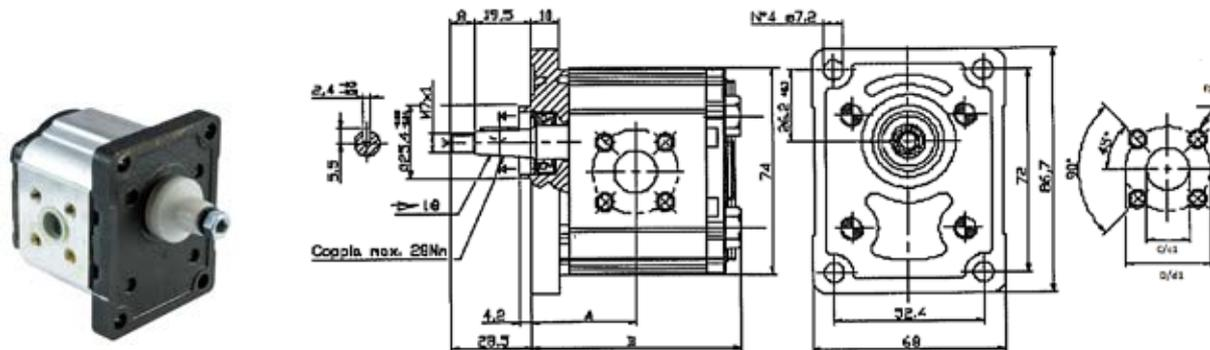
Pompe ad ingranaggi gruppo 1 made in italy con flangia e coperchio in ghisa

Art./Ref.	Cilindrata/ Displacement	Pressione max (bar)/ Pression max (bar)	Rotazione/ Rotation	Velocità rotativa/ Rotative speed	CH mm	A mm	B mm	C mm	D mm	F mm	c1	d1	f1
84768	1,05	250	DX	5000	2,4	31,90	65,60	13	30	M6	13	30	M6
84769	1,45	260	DX	5000	2,4	32,75	67,30	13	30	M6	13	30	M6
84770	2,45	260	DX	5000	2,4	34,50	70,80	13	30	M6	13	30	M6
84771	3,05	260	DX	5000	2,4	35,50	72,80	13	30	M6	13	30	M6
84772	3,80	260	DX	4500	2,4	36,90	75,60	13	30	M6	13	30	M6
84773	4,70	240	DX	4500	2,4	38,45	78,70	13	30	M6	13	30	M6
84774	5,55	200	DX	4000	2,4	40,00	81,80	13	30	M6	13	30	M6
84775	6,25	190	DX	3750	2,4	41,25	84,30	13	30	M6	13	30	M6

POMPE AD INGRANAGGI - GR 1 STANDARD

POMPES A ENGRENAGES - GR 1

GEAR PUMPS - GR 1

ZAHNRADPUMPEN - GR 1

BOMBA CON ENGRANAJE - GR 1

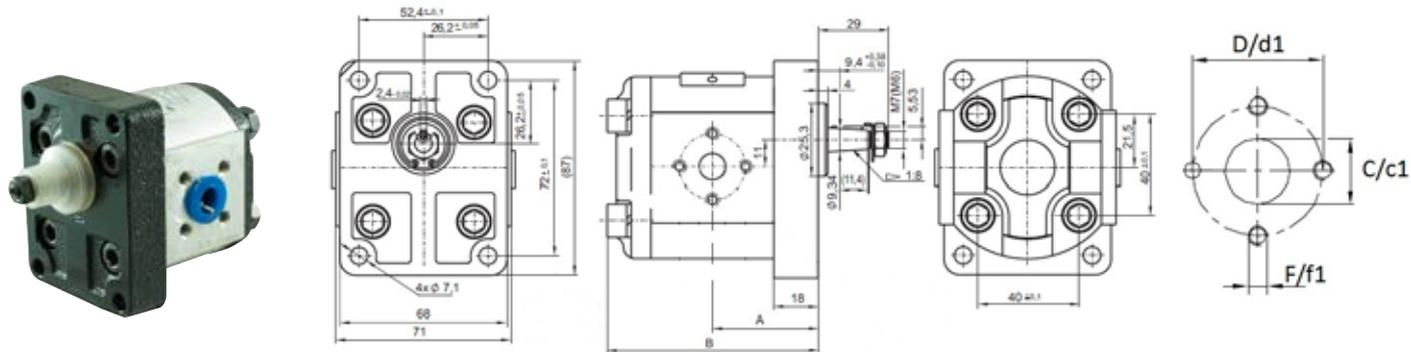

Art./Ref.	Cilindrata/ Displacement	Pressione max (bar)/ Pression max (bar)	Rotazione/ Rotation	Velocità rotativa/ Rotative speed	CH mm	A mm	B mm	C mm	D mm	F mm	c1	d1	f1
16698	1,6	200	DX	3500	2,4	40,3	80	13	30	M6	13	30	M6
16702	2,5	200	DX	3500	2,4	42,1	87,5	13	30	M6	13	30	M6
16594	2,5	200	SX	3500	2,4	42,1	87,5	13	30	M6	13	30	M6
12169	4,2	200	DX	3000	2,4	45,5	94,5	13	30	M6	13	30	M6
12170	4,2	200	SX	3000	2,4	45,5	94,5	13	30	M6	13	30	M6
16700	5,7	180	DX	2500	2,4	48,5	100,5	13	30	M6	13	30	M6
16701	5,7	180	SX	2500	2,4	48,5	100,5	13	30	M6	13	30	M6

POMPE AD INGRANAGGI GRUPPO 2 MADE IN ITALY

POMPES A ENGRENAGES GROUPE 2 MADE IN ITALY

GEAR PUMPS GROUP 2 MADE IN ITALY

ZAHNRADPUMPEN 2 GRUPPE MADE IN ITALY

BOMBA CON ENGRANAJE GRUPPO 2 MADE IN ITALY

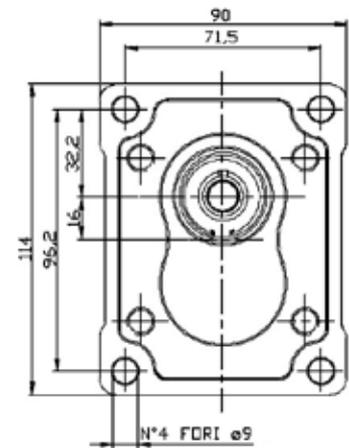
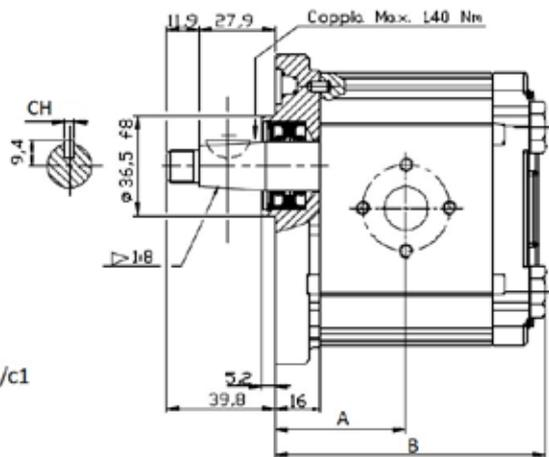
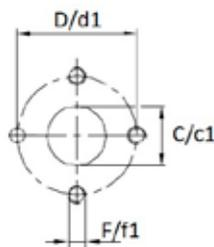

POMPE AD INGRANAGGI GRUPPO 2 MADE IN ITALY

Gear pumps group 2 made in Italy with flanges in cast iron

Art./Ref.	Cilindrata/ Displacement	Pressione max (bar)/ Pression max (bar)	Rotazione/ Rotation	Velocità rotativa/ Rotative speed	CH mm	A mm	B mm	C mm	D mm	F mm	c1	d1	f1	Brand	Rif. Orig./ Orig. Ref.
17000	4,1	250	SX	4000	3,15	40	83,5	13	30	M6	13	30	M6	-	-
17001	4,1	250	DX	4000	3,15	40	83,5	13	30	M6	13	30	M6	PLESSEY	C10
17002	6,2	250	SX	3500	3,15	41,5	86,5	13	30	M6	13	30	M6	PLESSEY	A14
17003	6,2	250	DX	3500	3,15	41,5	86,5	13	30	M6	13	30	M6	PLESSEY	C14
17004	8,2	250	SX	3500	3,15	43	89,5	13	30	M6	13	30	M6	PLESSEY	A18
17005	8,2	250	DX	3500	3,15	43	89,5	13	30	M6	13	30	M6	PLESSEY	C18
17006	11,2	250	SX	3500	3,15	45,15	93,8	13	30	M6	13	30	M6	PLESSEY - FIAT	5179730, A22, A25
17007	11,2	250	DX	3500	3,15	45,15	93,8	13	30	M6	13	30	M6	BOSCH - PLESSEY - FIAT	0.510.525.313, 5129481, 8273385, C22
17008	14	240	SX	3000	3,15	47,15	97,8	20	40	M8	13	30	M6	PLESSEY	A31
17009	14	240	DX	3000	3,15	47,15	97,8	20	40	M8	13	30	M6	PLESSEY	C31
17010	16	240	SX	3000	3,15	48,6	100,7	20	40	M8	13	30	M6	PLESSEY	A33
17011	16	240	DX	3000	3,15	48,6	100,7	20	40	M8	13	30	M6	PLESSEY	C33
17012	20	200	SX	3000	3,15	51,5	106,5	20	40	M8	13	30	M6	PLESSEY	A42
17013	20	200	DX	3000	3,15	51,5	106,5	20	40	M8	13	30	M6	PLESSEY - FIAT	8273977, C42
34421	25,1	170	SX	2500	3,15	59,25	122	20	40	M8	13	30	M6	-	-
34420	25,1	170	DX	2500	3,15	59,25	122	20	40	M8	13	30	M6	-	-
34423	35,2	155	SX	2500	4	69,5	141,5	21	40	M8	19	40	M8	-	-
34422	35,2	155	DX	2500	4	69,5	141,5	21	40	M8	19	40	M8	-	-

POMPE GRUPPO 2

POMPES GR.2 (MOD. STANDARD)

PUMPS GR. 2 (STANDARD TYPE)

PUMPEN GR. 2 (STANDARD AUSFUHRUNG)

BOMBA GR. 2 (MODELLO STANDARD)

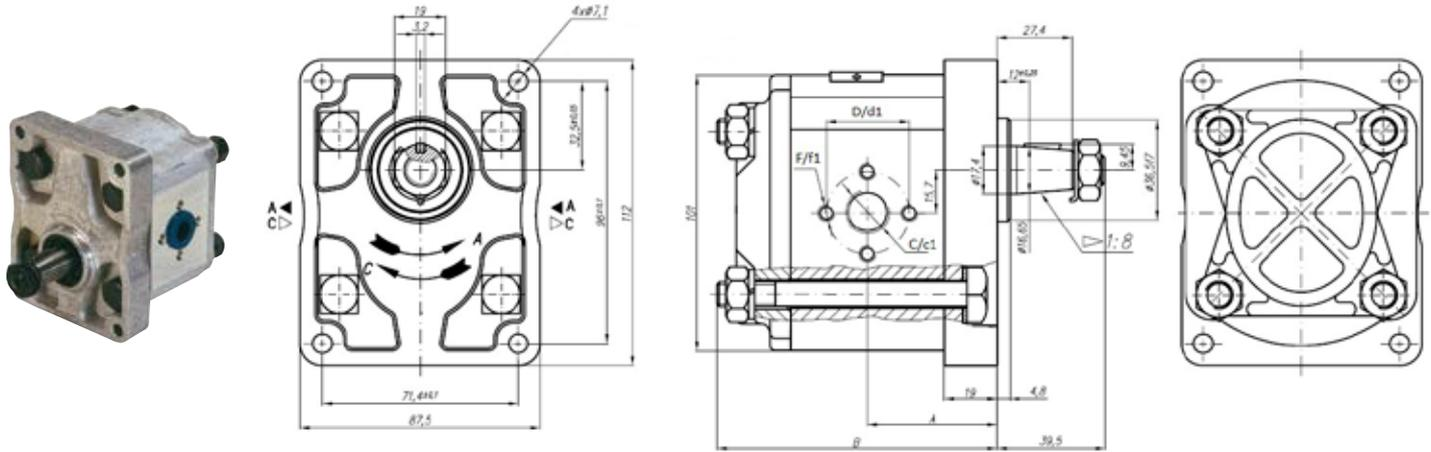
Pompe oleodinamiche gruppo 2. Peso approssimativo Kg. 2,3

Modello standard. Rotazione: C = destra, A = sinistra

Art./ Ref.	Cilindrata/ Displacement	Pressione max (bar)/ Pression max (bar)	Rotazione/ Rotation	Velocità rotativa/ Rotative speed	A mm	B mm	C mm	D mm	F mm	c1	d1	f1	Tipo/ Type	Brand	Applicazione/Application	Rif. Orig./ Orig. Ref.
04400	4,5	175	DX	3500	42,5	92,8	13	30	M6	13	30	M6	C10	PLESSEY - FIAT	300, 640, 650	1901316, C10
04401	6,3	175	SX	3500	42,5	92,8	13	30	M6	13	30	M6	A14	PLESSEY - FIAT	480, 500	8281794, A14
04402	6,3	175	DX	3500	42,5	92,8	13	30	M6	13	30	M6	C14	PLESSEY - FIAT	350, 640, 780	8273970, C14
04403	8,2	175	SX	3500	42,5	92,8	13	30	M6	13	30	M6	A18	PLESSEY - FIAT	350, 440, 446, 460, 470, 480, 500, 60, 60.66, 605, 70, 70.66, 80, 80.66, 80.70	5130127, A18
04404	8,2	175	DX	3500	42,5	92,8	13	30	M6	13	30	M6	C18	PLESSEY - FIAT - FORD	100, 1000, 120, 1300, 1355, 300, 350, 355, 40, 420, 45.66, 455, 466, 470, 474, 50, 505, 55.66, 566, 570, 580, 60.66, 640, 650, 666, 670, 680, 70.66, 750, 766, 780, 80, 850, 880, 90, 980	5130133, 5179724, C18
04407	11,3	175	SX	3500	48	103,9	19	40	M8	13	30	M6	A22/ A25	PLESSEY - FIAT	450, 466, 474, 480, 500, 540, 55, 55.46, 566, 570, 580, 640, 65, 65.46, 65.66, 650, 655, 666, 670, 680, 70.66, 750, 766, 780, 80.46, 80.56, 80.60, 80.66, 80.70, 80.75, 80.76, 80.95, 805, 880, 980	5129478, 5179730, 8280040, A22, A25
04408	11,4	175	DX	3500	48	103,9	19	40	M8	13	30	M6	C22/ C25	PLESSEY - FIAT	440, 446, 450, 466, 480, 500, 55, 55.46, 55.66, 566, 570, 60, 60.66, 65, 65.66, 666, 670, 70, 70.66, 766, 80, 80.60, 80.66, 80.70, 880, 980	5129481, 8273385, C22, C25
04411	15	175	SX	2500	51	109,7	19	40	M8	13	30	M6	A31/ A33	PLESSEY - FIAT - FORD	100, 1000, 110, 115, 1180, 1280, 130, 1355, 140, 45, 465, 466, 480, 50, 500, 55, 566, 580, 60, 640, 65, 655, 666, 680, 70, 765, 766, 780, 80, 80.56, 80.66, 80.76, 850, 880, 90, 955, 980	8280127, 5129483, 5179719, A31, A33
04412	15	175	DX	2500	51	109,7	19	40	M8	13	30	M6	C31/ C33	PLESSEY - FIAT	480, 500, 80.75, 80.95	5129486, 8273975, C31, C33
04413	19	175	SX	2500	54	116,3	19	40	M8	13	30	M6	A42	PLESSEY - FIAT	100, 115, 130, 1380, 140, 1580, 160, 180, 1880, 466, 55, 55.66, 566, 580, 60, 60.66, 666, 680, 766, 780, 80, 85, 855, 880, 90, 95, 980	5129488, A42
04414	19	175	DX	2500	54	116,3	19	40	M8	13	30	M6	C42	PLESSEY - FIAT	F 100, F 110, F 120, F 130	8273977, C42

POMPE GRUPPO 2 (MODELLO ECO)

POMPES GR 2 (MOD. ECO)

PUMPS GR 2 (ECO TYPE)

PUMPEN GR 2 (ECO AUSFUHRUNG)

BOMBAS GR 2 (MODELLO ECO)

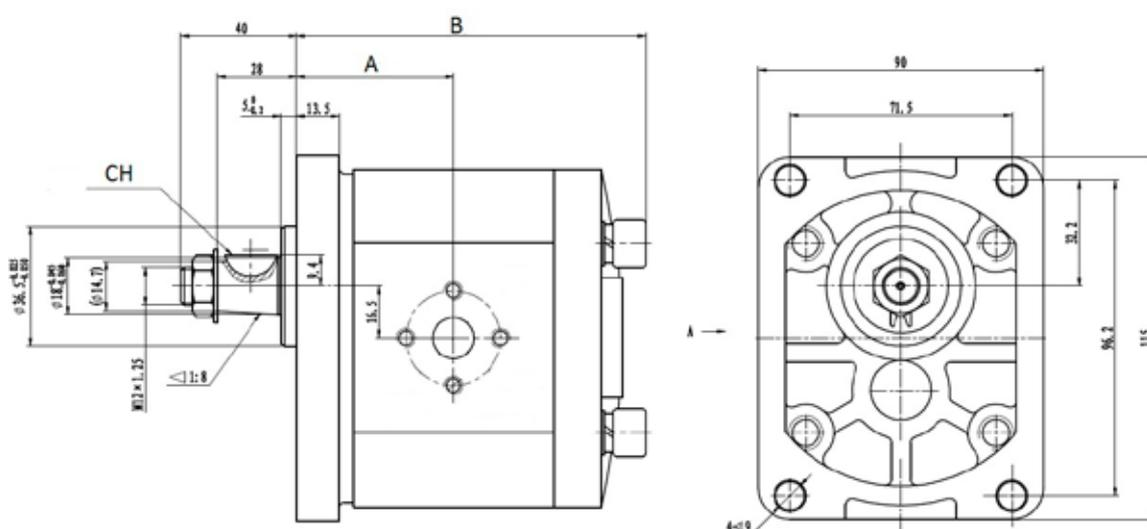

Art./Ref.	Cilindrata/ Displacement	Pressione max (bar)/ Pression max (bar)	Rotazione/ Rotation	Velocità rotativa/ Rotative speed	CH mm	A mm	B mm	C mm	D mm	F mm	c1	d1	f1
61500	4	200	DX	3500	3,15	43,3	95,5	13	30	M6	13	30	M6
61501	6	200	SX	3500	3,15	45	99	13	30	M6	13	30	M6
61502	6	200	DX	3500	3,15	45	99	13	30	M6	13	30	M6
61503	8	200	SX	3500	3,15	46,5	102	13	30	M6	13	30	M6
61504	8	200	DX	3500	3,15	46,5	102	13	30	M6	13	30	M6
61505	12	200	SX	3500	3,15	49,5	108	20	40	M8	13	30	M6
61506	12	200	DX	3500	3,15	49,5	108	20	40	M8	13	30	M6
61507	16	200	SX	3000	3,15	52,5	114	20	40	M8	13	30	M6
61508	16	200	DX	3000	3,15	52,5	114	20	40	M8	13	30	M6
61509	20	200	SX	3000	3,15	56	121	20	40	M8	13	30	M6
61510	20	200	DX	3000	3,15	56	121	20	40	M8	13	30	M6

POMPE AD INGRANAGGI GRUPPO 3 MADE IN ITALY

POMPES A ENGRENAGES GROUPE 3 MADE IN ITALY

GEAR PUMPS GROUP 3 MADE IN ITALY

ZAHNRADPUMPEN 3 GRUPPE MADE IN ITALY

BOMBA CON ENGRANAJE GRUPO 3 MADE IN ITALY

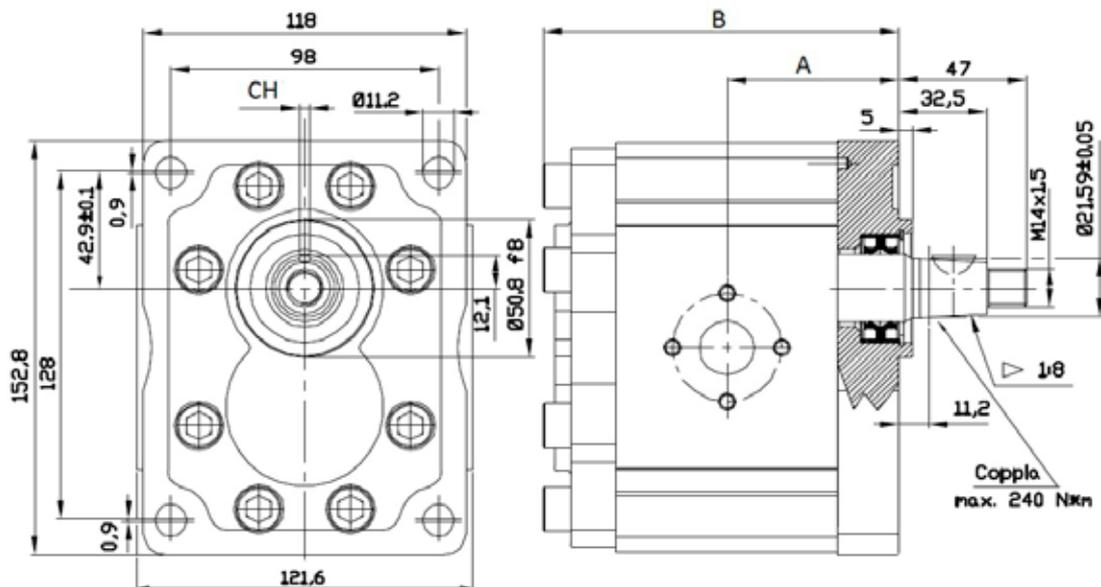
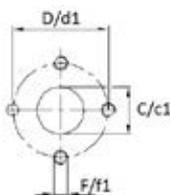

Pompe ad ingranaggi gruppo 3 made in italy con flangia e coperchio in ghisa
 Gear pumps group 3 made in Italy with flanges in cast iron

Art./Ref.	Cilindrata/ Displacement	Pressione max (bar)/ Pression max (bar)	Rotazione/ Rotation	Velocità rotativa/ Rotative speed	CH mm	A mm	B mm	C mm	c1	D mm	d1	F mm	f1
89290	28	260	DX	3000	4	59,70	123,70	27	19	51	40	M10	M8
89291	28	260	SX	3000	4	59,70	123,70	27	19	51	40	M10	M8
89292	32	260	DX	3000	4	61,20	126,90	27	19	51	40	M10	M8
89293	32	260	SX	3000	4	61,20	126,90	27	19	51	40	M10	M8
89294	38	240	DX	3000	4	63,50	131,50	27	19	51	40	M10	M8
89295	38	240	SX	3000	4	63,5	131,50	27	19	51	40	M10	M8
89296	42	240	DX	3000	4	65	134,50	27	19	51	40	M10	M8
89297	42	240	SX	3000	4	65	134,50	27	19	51	40	M10	M8
89298	48	240	DX	3000	4	72,30	149,10	27	19	51	40	M10	M8
89299	48	240	SX	3000	4	72,30	149,10	27	19	51	40	M10	M8
89300	53	220	DX	3000	4	74,20	152,90	27	19	51	40	M10	M8
89301	53	220	SX	3000	4	74,20	152,90	27	19	51	40	M10	M8
89302	63	200	DX	2100	4	78	160,50	27	19	51	40	M10	M8
89303	63	200	SX	2100	4	78	160,50	27	19	51	40	M10	M8

POMPA AD INGRANAGGI GRUPPO 3 STANDARD

POMPES GR.3 (MOD. STANDARD)

PUMP GR.3 (STANDARD TYPE)

PUMPEN GR. 3 (STANDARD AUSFUHRUNG)

BOMBA GR. 3 (MODELLO STANDARD)

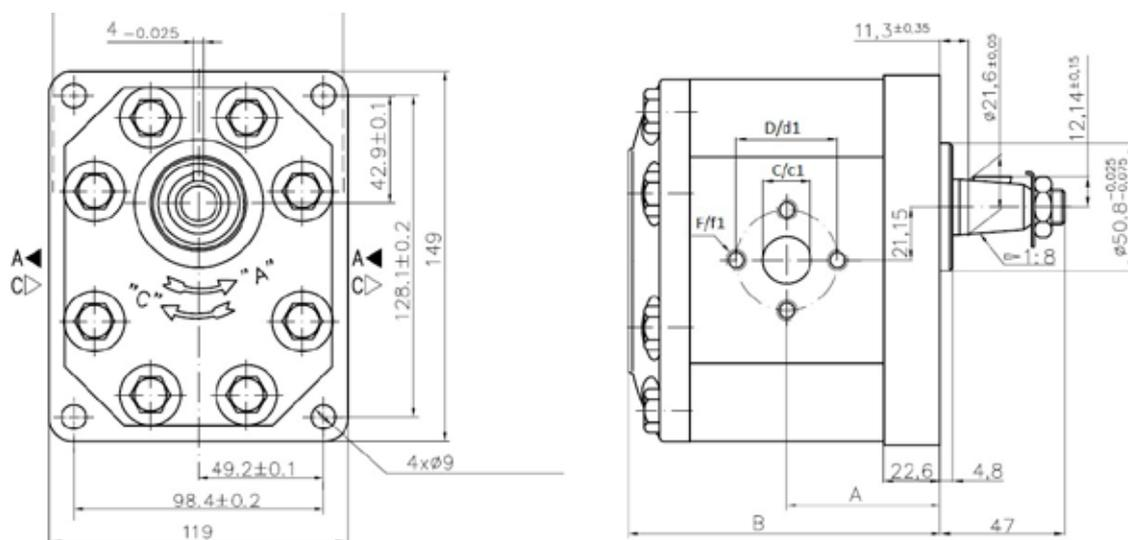
**APPLICAZIONE SU TRATTORI FIAT**

Art./Ref.	Cilindrata/ Displacement	Pressione max (bar)/Pression max (bar)	Rotazione/ Rotation	Velocità rotativa/ Rotative speed	A mm	B mm	C mm	D mm	F mm	c1	d1	f1	Tipo/ Type	Brand	Applicazione/ Application	Rif. Orig./ Orig. Ref.
04416	20	200	SX	3000	56,1	116,7	19	40	M8	19	40	M8	A43X	PLESSEY - FIAT	1000, 1300	8282449, A43X
04419	25	200	SX	3000	58,3	121,1	19	40	M8	19	40	M8	A54X	PLESSEY - FIAT - MASSEY FERGUSON	4, AD4, FL 4, FL4C	8272095, 3301295, A54X
04420	25	200	DX	3000	58,3	121,1	19	40	M8	19	40	M8	C54X	PLESSEY - FIAT	-	8272028, C54X
04424	32	200	SX	2500	62	128,3	27	51	M10	19	40	M8	A72X	PLESSEY - FIAT	TL5	8272814, A72X
04425	32	200	DX	2500	62	128,3	27	51	M10	19	40	m8	C72X	PLESSEY - FIAT - MASSEY FERGUSON	-	8273030, 1425495, C72X
04426	42	190	SX	2300	66,3	137	27	51	M10	19	40	M8	A94X	PLESSEY	-	A94X
04427	42	190	DX	2300	66,3	137	27	51	M10	19	40	M8	C94X	PLESSEY - FIAT	-	8272820, C94X

MOTORI AD INGRANAGGI BIDIREZIONALI GRUPPO 2

MOTEUR A ENGRANAGES GR.2
 GEAR MOTOR GROUP 2 REVERSIBLE
 ZAHNRADMOTOREN GR.2 UMKEHRBAR
 MOTOR CON ENGRANAJE GR.2

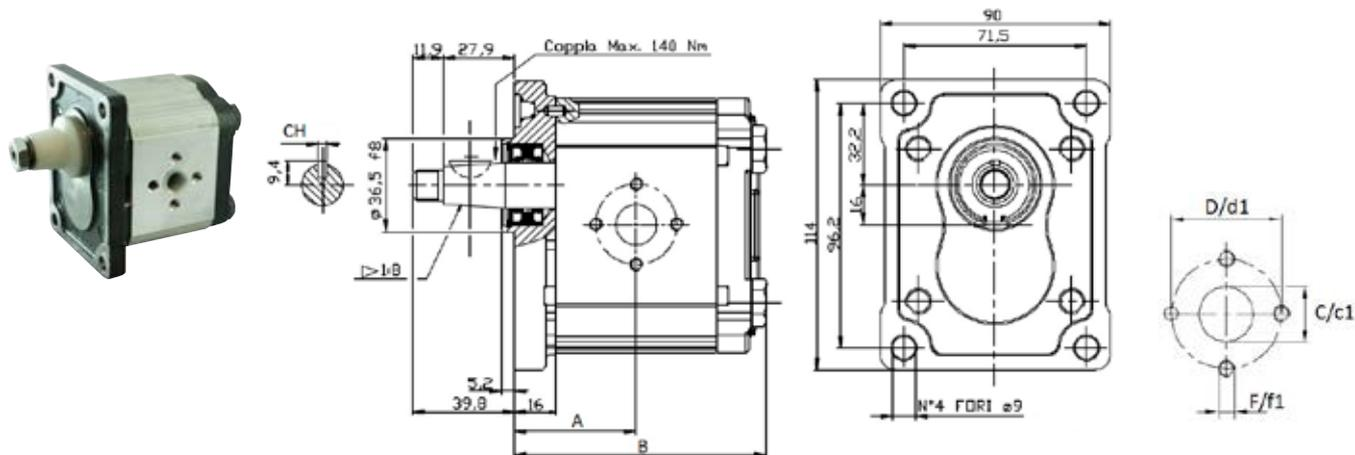

Art./Ref.	Cilindrata/Di- placement	Pressione max (bar)/ Pression max (bar)	Rotazione/Rotation	Velocità rotativa/ Rotative speed	CH mm	A mm	B mm	C mm	D mm	F mm	c1	d1	f1
84701	8,2	250	Reversibile / Reversible	3500	3,15	43	89,5	13	30	M6	13	30	M6
84702	11,2	250	Reversibile / Reversible	3500	3,15	45,15	93,8	13	30	M6	13	30	M6
84703	14	240	Reversibile / Reversible	3000	3,15	47,15	97,8	20	40	M8	20	40	M8
84540	16	240	Reversibile / Reversible	3000	3,15	48,6	100,7	20	40	M8	20	40	M8
84704	20	200	Reversibile / Reversible	3000	3,15	51,5	106,5	20	40	M8	20	40	M8
84705	22,5	170	Reversibile / Reversible	2500	3,15	57,35	118,2	20	40	M8	20	40	M8

FLANGE A 4 FORI PER POMPE GR 1, COMPLETE DI "OR"

FLASQUES TROUS AVEC JOINTS TORIQUES
 4 HOLES FLANGES WITH O - RING
 4 LÖECHER - FLANSCH, MIT O - RINGEN
 BRIDA PARA SALIDA BOMBAS COMPLETE DI "OR"

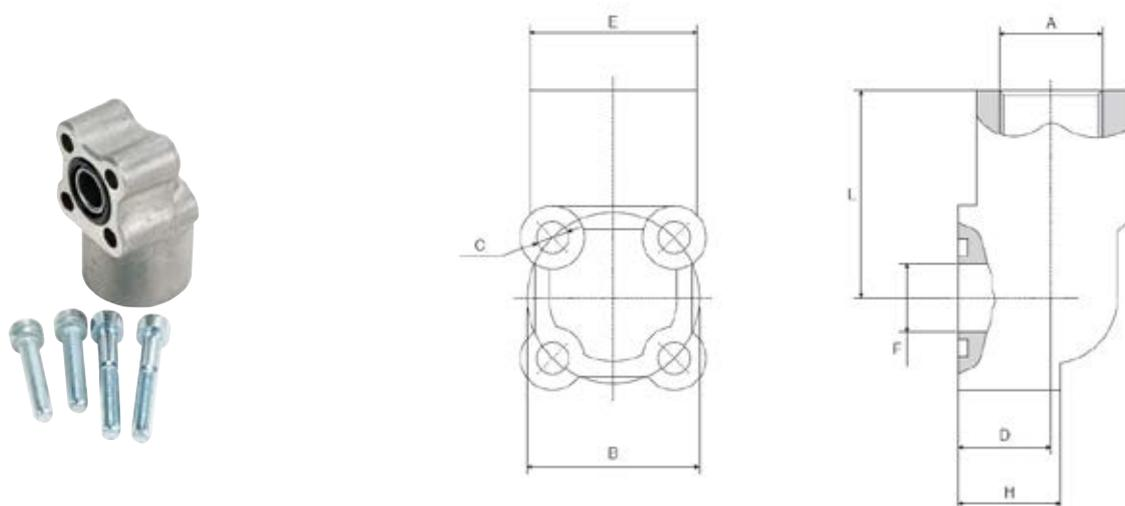

Art./Ref.	A mm	B mm	C mm	D mm	E mm	F mm	H mm	L mm
17490	3/8"	30	6,5	18	33	11,5	20	39
17491	1/2"	30	6,5	18	33	11,5	20	39

FLANGE A 3 FORI PER POMPE, COMPLETE DI "OR" VITI E RONDELLE

FLASQUES TROUS AVEC JOINTS TORIQUES

3 HOLES FLANGES WITH O - RING

3 LÖECHER - FLANSCH, MIT O - RINGEN

BRIDA PARA SALIDA BOMBAS COMPLETE DI "OR"

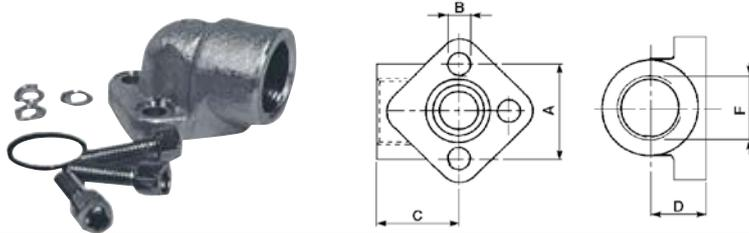

Art./Ref.	A mm	B mm	C mm	D mm	Filettatura/Thread
27253	30	6.5	25	17	3/8"
27254	30	6.5	25	17	1/2"
27255	40	8.5	36	21	3/8"
27256	40	8.5	36	21	1/2"
27257	40	8.5	36	21	3/4"
27258	51	10.5	45	25	3/4"
27259	56	10.5	47	23	3/4"
27260	51	10.5	45	25	1"
27261	56	10.5	47	25	1"
27262	62	10.5	56	33	1"1/4"

VITI PER IL FISSAGGIO DELLE FLANGE

VIS FIXATION FLASQUES

FLANGES SCREWS

FLANSCH SCHRAUBEN

TORNILLOS PARA FIJACIÓN DE BRIDAS



Art./Ref.	Note/Note	Tipo/Type
05498	1/4"-20X20/1/4"-20X20/1/4"-20X20/1/4"-20X20/1/4"-20X20	WITHWORTH
05499	5/16"-18X25/5/16"-18X25/5/16"-18X25/5/16"-18X25/5/16"-18X25	WITHWORTH
05500	3/8"-16X30/3/8"-16X30/3/8"-16X30/3/8"-16X30/3/8"-16X30	WITHWORTH

POMPE OLEODINAMICHE AD INGRANAGGI

POMPES HYDRAULIQUES À ENGRENAGES

HYDRAULIC GEAR PUMPS

HYDRAULISCHE ZAHNRADPUMPEN

BOMBAS OLEODINÁ MICAS DE ENGRANAJE

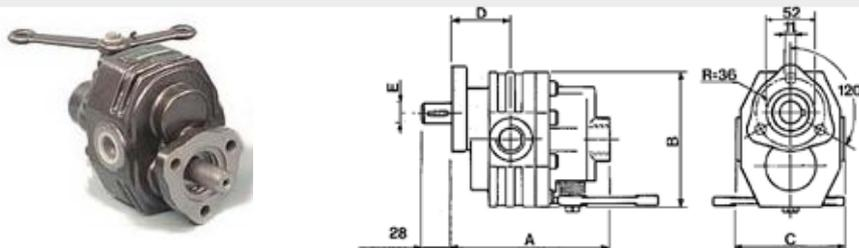

Serie normale con distributore

Art./Ref.	Cilindrata/Di- placement	Pressione max (bar)/Pression max (bar)	Velocità rota- tiva/Rotative speed	Rotazione/ Rotation	Filettatura/ Thread	A mm	B mm	C mm	D mm	E mm
00828	38,4	180	1800	SX	3/4"	169	136	112	64	22
00829	60	150	1800	SX	1" - 3/4"	186	138	112	67	22

POMPE OLEODINAMICHE AD INGRANAGGI A COMPENSAZIONE ASSIALE

POMPES HYDRAULIQUES À ENGRENAGES
 HYDRAULIC GEAR PUMPS AXIAL COMPENSATION
 HYDRAULISCHE ZAHNRADPUMPEN
 BOMBAS OLEODINÁ MICAS DE ENGRANAJE

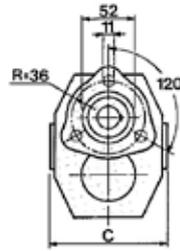
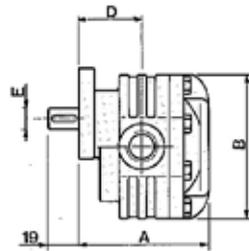
**Pompe oleodinamiche ad ingranaggi a compensazione assiale
 Hydraulic gear pumps axial compensation**

Art./Ref.	Cilindrata/Di- placement	Pressione max (bar)/ Pression max (bar)	Velocità rotativa/ Rotative speed	Rotazione/ Rotation	Filettatura/ Thread	A mm	B mm	C mm	D mm	E mm
01136	38,4	180	1800	SX	3/4"	128	138	112	64	22
02779	60	170	1800	SX	1"	144	138	112	67	22

PRESA DI FORZA 1"3/8 PER POMPA OLEODINAMICA

PRISE DE FORCE 1"3/8 POUR POMPES HYDRAULIQUES
 1" 3/8 SPLINED SHAFT FOR HYDRAULIC PUMPS
 ZAPFWELLE 1"3/8 FÜR HYDRAULISCHE PUMPE
 TOMA DE FUERZA 1" 3/8 PARA BOMBA OLEODINAMICA

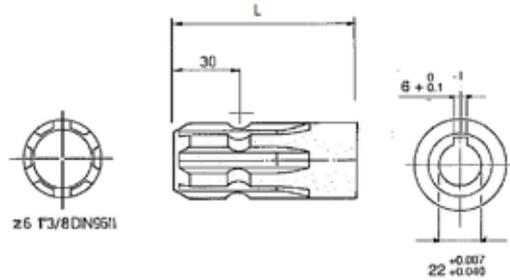

Art./Ref.	Tipo/Type	Lunghezza mm/Lenght mm
00655	1"3/8" Z6	75
08018	1"3/8" Z6	100

BUSSOLA SCANALATA 1" 3/8, Z6 PER POMPA OLEODINAMICA

DOUILLE CANNELÉ 1" 3/8 POUR POMPE HYDRAULIQUE
 Z6 COUPLING FOR 1" 3/8 HYDRAULIC PUMPS
 BUECHSE 1"3/8 Z6 FUER HYDRAULISCHE PUMPE
 CANA ESTRIADA 1"3/8, Z6 PARA BOMBA OLEODINAMICA

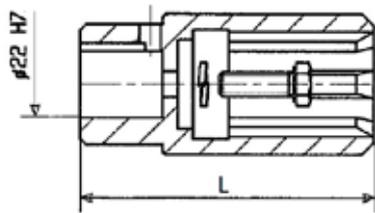

Art./Ref.	Tipo/Type	Tipo/Type	Lunghezza mm/Lenght mm
00653	1"3/8" Z6	1"3/8" Z6	97

TRAIÑO MASCHIO PER POMPE IDRAULICHE

COUPLEUR MÂLE POUR POMPES HYDRAULIQUES
 MALE COUPLING FOR HYDRAULIC PUMPS
 PROFILWELLE MIT LAGERUNG FÜR HYDR. PUMPE
 ACOPLADOR MACHO PARA BOMBA HIDRAÚLICA

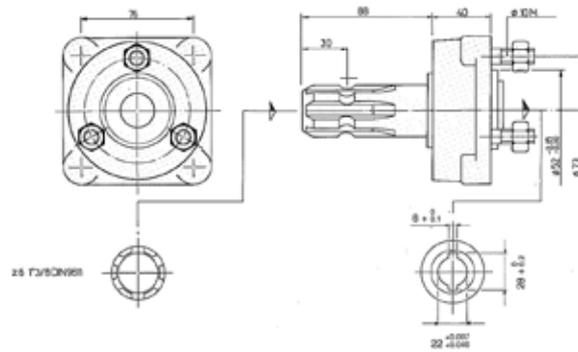

Art./Ref.	Tipo/Type
01253	1"3/8" Z6

TRAIÑO FEMMINA CON GIUNTO A SFERA PER POMPE IDRAULICHE

COUPLEUR FEMELLE AVEC JOINT A BILLES POUR POMPES HYDRAULIQUES
 FEMALE COUPLING WITH QUICK RELEASE
 AUTOMATISCHE PROFILBUCHSE MIT SCHNELLKUPPLUNG FÜR HYDR. PUMPE
 ACOPLADOR HEMBRA PARA BOMBA HIDRAÚLICA

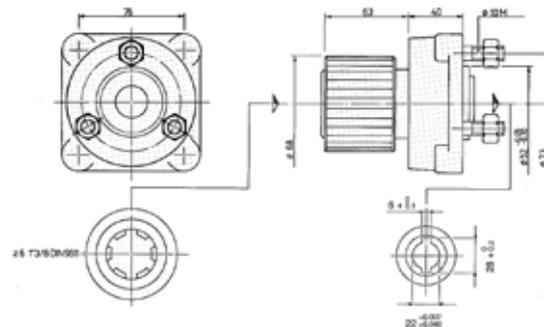

Art./Ref.	Tipo/Type
01210	1"3/8" Z6

POMPA A MANO: A SEMPLICE EFFETTO CON RUBINETTO DI DISCESA INCORPORATO CILINDRATA 50 CM3 ATTACCHI 1/2" GAS.

POMPE A MAIN: SIMPLE EFFET, AVEC ROBINET CHUTE INCORPORÉ. CYLINDRÉE 50 CM3 - COUPLEURS: 1/2" GAS.
 HAND PUMP: SINGLE ACTING, WITH BUILT IN SHUTOFF VALVE DISPLACEMENT: 50 CM3 . COUPLINGS: 1/2" GAS.
 HANDPUMPE: EINFACHWIRKEND, MIT EINGEBAUTEM RÜCKFLUSSHAHN. FÖRDERLEITUNG 50 CM3 ANSCHLÜSSE: 1/2" GAS
 BOMBA DE MANO: SIMPLE EFECTO CON PALANCA DE PRESIÓN INCORPORADA CILINDRADA 50 CM 3 ATAQUE: 1/2" GAS

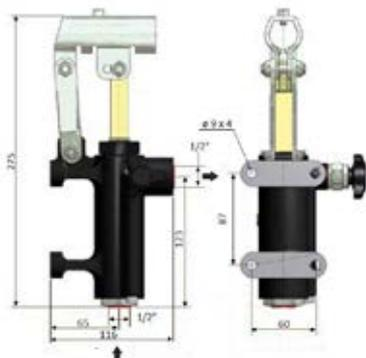

Art./Ref.	Cilindrata/Displacement	Pressione max (bar)/Pression max (bar)
01182	43,825	280

POMPA A MANO 25 CC DOPPIO EFFETTO CON RUBINETTO DI INVERSIONE COMPLETA DI SERBATOIO.
POMPE A MAIN 25 CC DOUBLE EFFET AVEC ROBINET D'INVERSION COMPLETE DE RESERVOIR.
HAND PUMP 25 CC DOUBLE ACTING WITH REVOLER TAP, WITH TANK.
HANDPUMPE 25 CC DOPPELWIRKEND MIT UMKEHRHAHN, MIT TANK.
BOMBA DE MANO 25 CC DOBLE EFECTO CON PALANCA DE INVERSIÓN Y DEPÓSITO

Art./Ref.	Cilindrata/Displacement	Pressione max (bar)/Pression max (bar)	Filettatura/Thread	Note/Note	Tipo/Type
04923	25	350	3/8"	SERBATOIO 3 LT	DOPPIO EFFETTO
04924	25	350	3/8"	SERBATOIO 5 LT	DOPPIO EFFETTO
04925	25	350	3/8"	SERBATOIO 7 LT	DOPPIO EFFETTO

POMPA A MANO 25 CC SEMPLICE EFFETTO CON VOLANTINO DI DISCESA COMPLETA DI SERBATOIO
POMPE A MAIN 25 CC SIMPLE EFFET AVEC VOLANT DE CHUTE AVEC RESERVOIR
HAND PUMP 25 CC SINGLE ACTING WITH LOWERING TAP, WITH TANK
HANDPUMPE 25 CC EINFACHWIRKEND MIT RUCKFLUSSHAHN, MIT TANK.
BOMBA MANO SIMPLE EFECTO CON RULETA DE REGULACIÓN Y DEPÓSITO

Art./Ref.	Cilindrata/Displacement	Pressione max (bar)/Pression max (bar)	Filettatura/Thread	Note/Note	Tipo/Type
03897	25	350	3/8"	SERBATOIO 3 LT	SEMPLICE EFFETTO
04921	25	350	3/8"	SERBATOIO 5 LT	SEMPLICE EFFETTO
04922	25	350	3/8"	SERBATOIO 7 LT	SEMPLICE EFFETTO

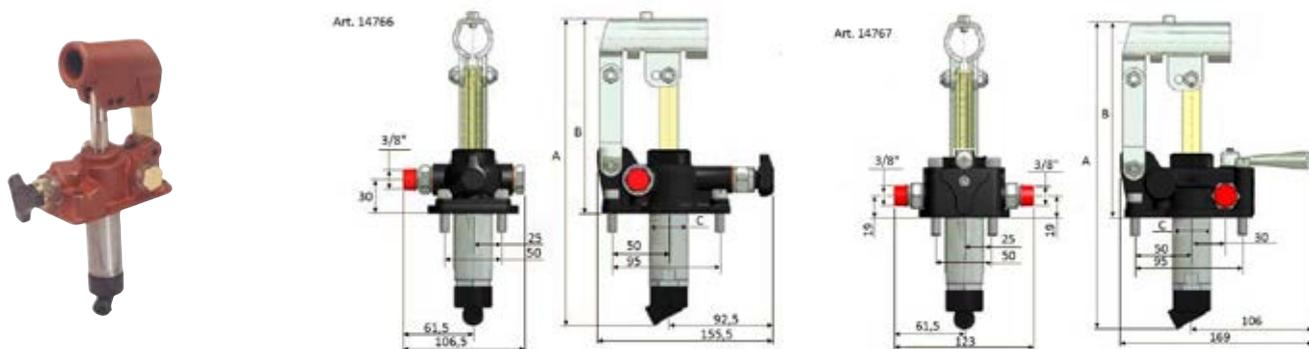
POMPA A MANO 25 CC SENZA SERBATOIO
POMPE A MAIN 25 CC SANS RESERVOIR
HAND PUMP 25 CC WITHOUT TANKS
HANDPUMPE 25 CC OHVE TANK.
BOMBA MANO 25 CC SIN DEPOSITO

Art./Ref.	Cilindrata/Displacement	Pressione max (bar)/Pression max (bar)	A mm	B mm	C mm	Filettatura/Thread	Note/Note	Tipo/Type
14766	25	350	273	172	34	3/8"	SENZA SERBATOIO	SEMPLICE EFFETTO
14767	25	350	273	172	34	3/8"	SENZA SERBATOIO	DOPPIO EFFETTO

KIT GUARNIZIONE PER POMPE A MANO DA 25 CC.

KIT JOINT POUR POMPE A MAIN 25 CC.

GASKET KIT FOR HAND PUMP 25 CC.

DICHTUNGSSATZ FÜR HANDPUMPE 25 CC.

KIT JUNTAS PARA BOMBA MANO 25 CC.



Art./Ref.
16611

SERBATOIO PER POMPA A MANO

TANK FOR HAND PUMPS

RESERVOIR POUR POMPES A MAIN

TANK FUER HANDPUMPEN

DEPOSITO PARA BOMBAS DE MANO



Art./Ref.	Capacità/Capacity	Brand	Applicazione/Application
25998	3	A.M.A.	14766, 14767
19403	5	A.M.A.	14766, 14767

LEVA PER POMPA A MANO

LEVIER POUR POMPE A MAIN

LEVER FOR HAND PUMP

HEBEL FÜR HAND PUMPE

PALANCA PARA BOMBA DE MANO



Art./Ref.	Lunghezza mm/Lenght mm
12088	650

MOLTIPLICATORI PER POMPE IDRAULICHE GRUPPO 2

MULTIPLICATEURS POUR POMPES HYDRAULIQUES DU GROUPE 2

PUMPS OVERDRIVE GR. 2

GETRIEBE HYDR. PUMPEN GR.2

MULTIPLICADORES PARA POMPE HIDRAÚLICO GRUPO 2

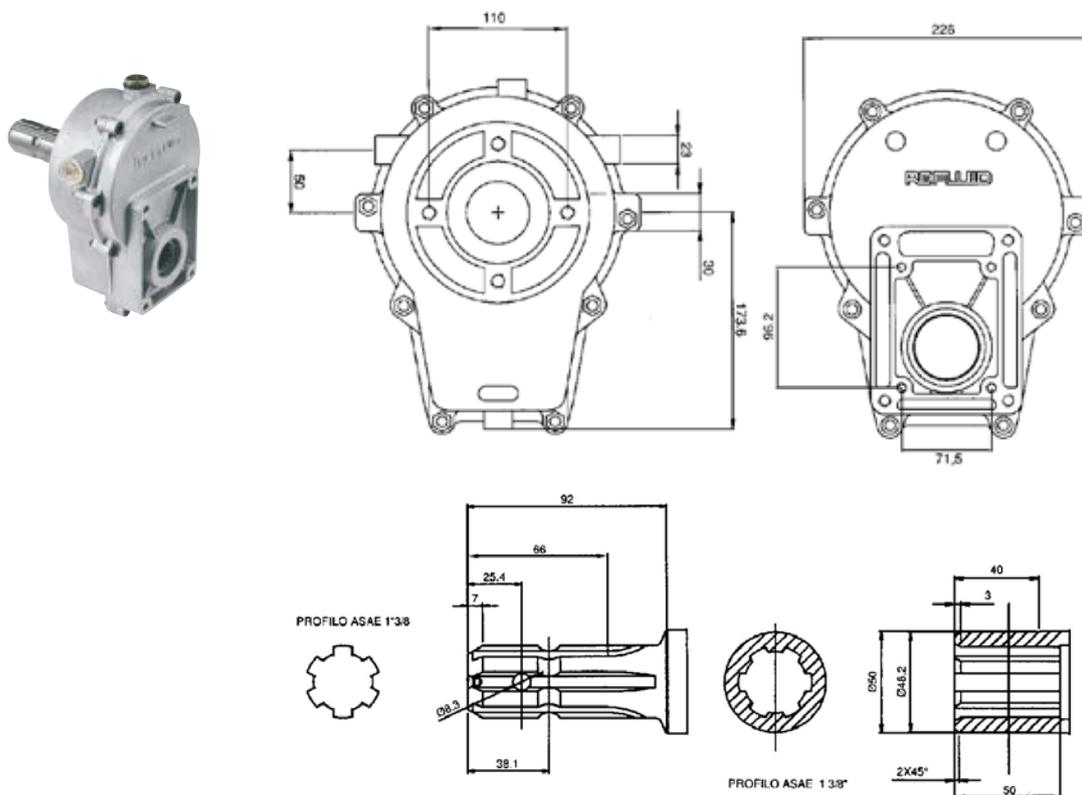
Temperatura di esercizio -20°/ +120° C. Olio CPL/CC 150 - DIN 5157. Rotazione destra massima: 3000 giri/1'.
Working temperature -20 / +180° C. Oil CPL/CC 150 - DIN 5157. Right hand rotation max 3000 RMP 1'.

Art./Ref.	Note/Notes	Tipo/Type	Rapporto/Ratio
16825	ingresso / inlet 540 g/min (rpm) - uscita / outlet 1080 g/min (rpm)	1"3/8" MASCHIO/MALE	1:2
16826	ingresso / inlet 540 g/min (rpm) - uscita / outlet 1080 g/min (rpm)	1"3/8" FEMMINA/FEMALE	1:2
16827	ingresso / inlet 540 g/min (rpm) - uscita / outlet 1080 g/min (rpm)	1"3/8" FEMMINA I.R./FEMALE	1:2
17246	ingresso / inlet 540 g/min (rpm) - uscita / outlet 1620 g/min (rpm)	1"3/8" MASCHIO/MALE	1:3
17249	ingresso / inlet 540 g/min (rpm) - uscita / outlet 1620 g/min (rpm)	1"3/8" FEMMINA/FEMALE	1:3
61245	ingresso / inlet 540 g/min (rpm) - uscita / outlet 1620 g/min (rpm)	1"3/8" FEMMINA I.R./FEMALE	1:3
17247	ingresso / inlet 540 g/min (rpm) - uscita / outlet 1836 g/min (rpm)	1"3/8" MASCHIO/MALE	1:3,5
17250	ingresso / inlet 540 g/min (rpm) - uscita / outlet 1836 g/min (rpm)	1"3/8" FEMMINA/FEMALE	1:3,5
61246	ingresso / inlet 540 g/min (rpm) - uscita / outlet 1836 g/min (rpm)	1"3/8" FEMMINA I.R./FEMALE	1:3,5
17248	ingresso / inlet 540 g/min (rpm) - uscita / outlet 2052 g/min (rpm)	1"3/8" MASCHIO/MALE	1:3,8
17251	ingresso / inlet 540 g/min (rpm) - uscita / outlet 2052 g/min (rpm)	1"3/8" FEMMINA/FEMALE	1:3,8
61247	ingresso / inlet 540 g/min (rpm) - uscita / outlet 2052 g/min (rpm)	1"3/8" FEMMINA I.R./FEMALE	1:3,8

MOLTIPLICATORI PER POMPE IDRAULICHE GRUPPO 3

MULTIPLICATEURS POUR POMPES HYDRAULIQUES DU GROUPE 3

PUMPS OVERDRIVE GROUP 3

GETRIEBE HYDR. PUMPEN GR. 3

MULTIPLICADORES PARA BOMBA HIDRAÚLICA GRUPO 3

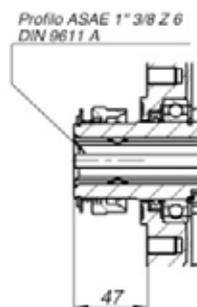
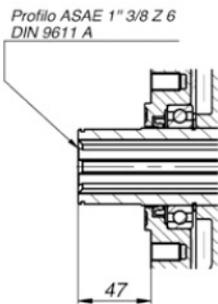
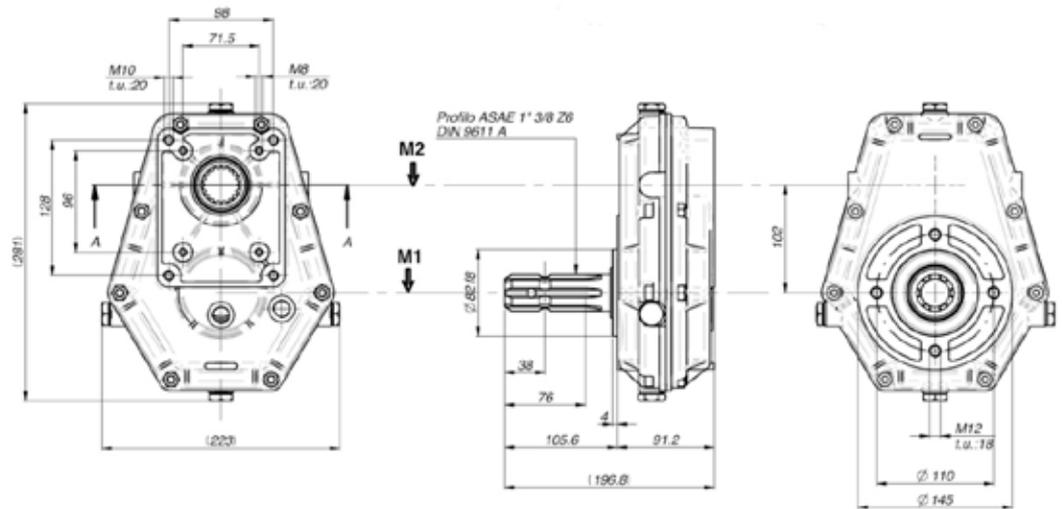

Temperatura di esercizio -20° / +180° C. Olio CPL/CC 150 - DIN 5117. Rotazione destra massima 3000 giri/1'.

1' Working temperature -20 / + 180° C. Oil CPL/CC 150 - DIN 5157. Right hand rotation max 3000 RMP 1'.

Art./Ref.	Note/Notes	Tipo/Type	Rapporto/Ratio
16828	ingresso / inlet 540 g/min (rpm) - uscita / outlet 1080 g/min (rpm)	1"3/8" MASCHIO/MALE	1:2
16829	ingresso / inlet 540 g/min (rpm) - uscita / outlet 1080 g/min (rpm)	1"3/8" FEMMINA/FEMALE	1:2
16830	ingresso / inlet 540 g/min (rpm) - uscita / outlet 1080 g/min (rpm)	1"3/8" FEMMINA I.R./FEMALE	1:2
04639	ingresso / inlet 540 g/min (rpm) - uscita / outlet 1620 g/min (rpm)	1"3/8" MASCHIO/MALE	1:3
04640	ingresso / inlet 540 g/min (rpm) - uscita / outlet 1620 g/min (rpm)	1"3/8" FEMMINA/FEMALE	1:3
12477	ingresso / inlet 540 g/min (rpm) - uscita / outlet 1620 g/min (rpm)	1"3/8" FEMMINA I.R./FEMALE	1:3
04641	ingresso / inlet 540 g/min (rpm) - uscita / outlet 1836 g/min (rpm)	1"3/8" MASCHIO/MALE	1:3,5
19436	ingresso / inlet 540 g/min (rpm) - uscita / outlet 1836 g/min (rpm)	1"3/8" MASCHIO/MALE GR2	1:3,5
04642	ingresso / inlet 540 g/min (rpm) - uscita / outlet 1836 g/min (rpm)	1"3/8" FEMMINA/FEMALE	1:3,5
12478	ingresso / inlet 540 g/min (rpm) - uscita / outlet 1836 g/min (rpm)	1"3/8" FEMMINA I.R./FEMALE	1:3,5
04643	ingresso / inlet 540 g/min (rpm) - uscita / outlet 2052 g/min (rpm)	1"3/8" MASCHIO/MALE	1:3,8
04667	ingresso / inlet 540 g/min (rpm) - uscita / outlet 2052 g/min (rpm)	1"3/8" FEMMINA/FEMALE	1:3,8
12479	ingresso / inlet 540 g/min (rpm) - uscita / outlet 2052 g/min (rpm)	1"3/8" FEMMINA I.R./FEMALE	1:3,8

INNESTO ELETTROMAGNETICO

COUPLEUR ELECTRO MAGNETIQUE
ELECTRO-MAGNETIC COUPLEUR
ELEKTRO MAGNETISCHE KUPPLUNG
EMBRAGUE ELECTROMAGNÉTICO

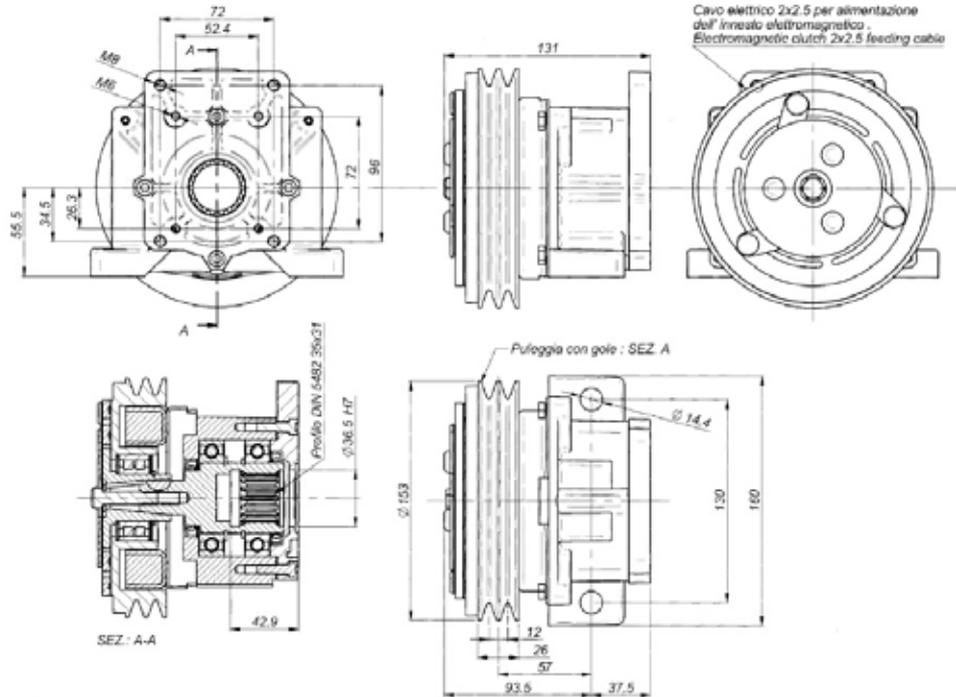

Art./Ref.	Note/Note	Tipo/Type	Volt/Volt
19448	10 daNm/10 daNm/10 daNm/10 daNm/10 daNm	GRUPPO/GROUP 1 - 2	12
12625	10 daNm/10 daNm/10 daNm/10 daNm/10 daNm	GRUPPO/GROUP 1 - 2	24
12626	14 daNm/14 daNm/14 daNm/14 daNm/14 daNm	GRUPPO/GROUP 1 - 2	12
12627	14 daNm/14 daNm/14 daNm/14 daNm/14 daNm	GRUPPO/GROUP 1 - 2	24

SEMIGIUNTI SCANALATI PER POMPA

DEMI-ACCOUPEMENTS CANNELES POUR POMPE
SPLINED HALF-COUPLEINGS FOR PUMP
GENUTETE HALBKUPPLUNGEN FÜR PUMPEN
ATAQUE PARA BOMBA

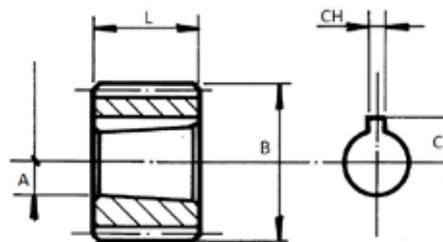

semigiunti scanalati per accoppiamento moltiplicatore - pompa
splined half-couplings between gear box and pump

Art./Ref.	A mm	B mm	C mm	L mm	CH mm	Note/Note	Tipo/Type	Albero/Albero	Brand	Applicazione/Application
12541	8	24,5	5,7	14,5	2,4	POMPA / PUMP GR.1	DIN 25X22 Z14	CONICO 1:8	A.M.A.	12539, 16838
12632	8	34,5	5,7	14,5	2,4	POMPA / PUMP GR.1	DIN 35X31 Z18	CONICO 1:8	A.M.A.	12625, 12626, 12627, 19448
12859	14,2	24,5	9,3	22	3,17	POMPA / PUMP GR.2	DIN 25X22 Z14	CONICO 1:8	A.M.A.	06680, 12540, 16825, 16826, 16827, 17246, 17247, 17248, 17249, 17250, 17251, 61245, 61246, 61247
08016	14,5	24,5	9,1	22,5	4	POMPA / PUMP GR.2	DIN 25X22 Z14	CONICO 1:8	A.M.A.	06680, 12540, 16825, 16826, 16827, 17246, 17247, 17248, 17249, 17250, 17251, 61245, 61246, 61247
08015	14,5	27,5	9,7	22,5	4	POMPA / PUMP GR.2	DIN 28X25 Z15	CONICO 1:8	A.M.A.	06681
08045	14,5	34,5	9,7	22,5	4	POMPA / PUMP GR.2	DIN 35X31 Z18	CONICO 1:8	A.M.A.	08025, 12625, 12626, 12627, 19436, 19448
12633	14,2	34,5	9,7	22	3,17	POMPA / PUMP GR.2	DIN 35X31 Z18	CONICO 1:8	A.M.A.	08025, 12625, 12626, 12627, 19436, 19448
08017	18,7	34,5	12,5	26	4	POMPA / PUMP GR.3	DIN 35X31 Z18	CONICO 1:8	A.M.A.	04639, 04640, 04641, 04642, 04643, 04667, 08025, 12477, 12478, 12479, 16796, 16828, 16829, 16830, 19436

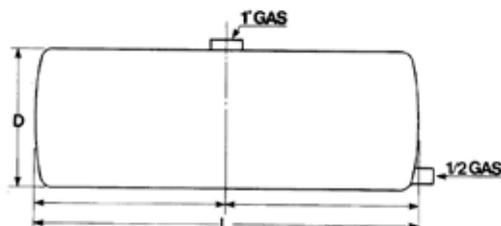
SERBATOIO PER OLIO
RESERVOIRS D'HUILE
OIL TANK
ÖLTANK
DEPÓSITO DE ACEITE

Art./Ref.	Capacità/Capacity	D mm	L mm
03469	11	200	350
01961	16	200	550
01962	20	200	670

TAPPO MANUALE CON DOPPIO SFIATO E ASTA LIVELLO
BOUCHON MANUEL AVEC LEVIER NIVEAU
MANUAL PLUG WITH LEVEL GAUGE
HANDPROPFEN MIT DOPPELNTÜFTTEROHR UND NIVEAU STANGE
TAPÓN MANUAL CON VARILLA DE NIVEL

Art./Ref.	Filettatura/Thread	Lunghezza mm/Lenght mm
01836	3/8"	200
01837	1/2"	200
01801	3/4"	200
01802	1"	200
01803	1"1/4"	200

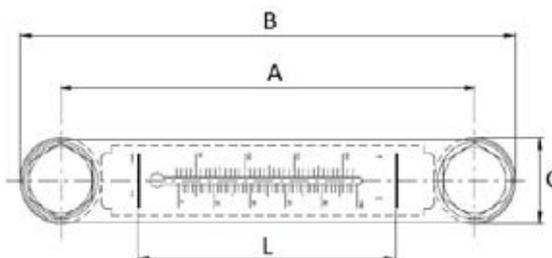
INDICATORE DI LIVELLO CON TERMOMETRO
NIVEAU AVEC THERMOMETRE
LEVEL GAUGE WITH THERMOMETER
ÖLSTANDANZEIGER MIT THERMOMETER
INDICADOR CON TERMÓMETRO

Art./Ref.	A mm	B mm	C mm	Lunghezza mm/Lenght mm	Filettatura/Thread
03233	76	100	27	39	M10
03234	127	150	27	80	M12

INDICATORE OTTICO DI LIVELLO

NIVEAU
LEVEL GAUGE
ÖLSTANDANZEIGER
INDICADOR OPTICO DE NIVEL



Art./Ref.	A mm	B mm	C mm	Lunghezza mm/Lenght mm	Filettatura/Thread
03219	76	100	27	39	M10
03220	127	150	27	80	M12

SPIA FILETTATA LIVELLO OLIO

NIVEAU HUILE
THREADED OIL LEVEL GAUGE
ÖLSTANDSCHAUGLAS
VISOR WEXAGONAL

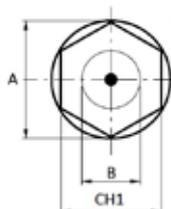

Art./Ref.	Filettatura/Thread	A mm	B mm	CH mm
03228	3/8"	22	12	18
03229	1/2"	28	16	24
03230	3/4"	36	21	30

TAPPO A PRESSIONE CON CESTELLO FILTRANTE

BOUCHON A PRESSION AVEC FILTRE
PRESSURE PLUG WITH FILTRATION BASKET
DRUCKPROPFEN MIT FILTRIERKORB
TAPÓN DE PRESIÓN CON FILTRO

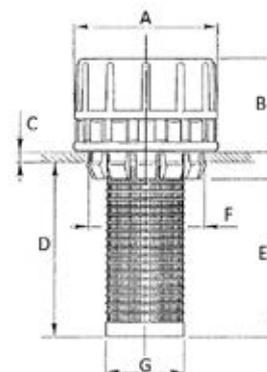

Art./Ref.	A mm	B mm	C mm	D mm	E mm	F mm	G mm
03258	70	46,5	2-8 mm	88	80	55	38

TAPPO MANUALE CON DOPPIO SFIATO

BOUCHON MANUEL
 MANUAL PLUG
 HANDPROPFEN MIT DOPPELNTÜFTTEROHR
 TAPÓN MANUAL



Art./Ref.	Filettatura/Thread
03262	3/8"
03263	1/2"
03259	3/4"
03260	1"
03261	1"1/4"

TAPPO CON FILTRO E CESTELLO

FILTRES HYDRAULIQUES
 CAP WITH FILTER AND BASKET
 STOPFEN MIT FILTER
 TAPÓN CON FILTRO Y CESTITO

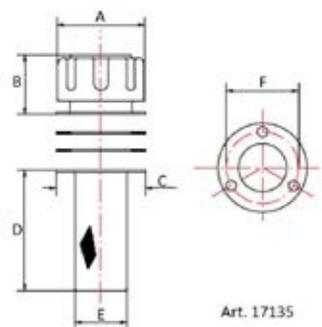

Art. 17135

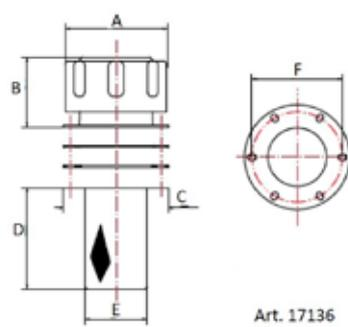

Art. 17136

Art./Ref.	A mm	B mm	C mm	D mm	E mm	F mm	Tipo/Type
17135	48	37	52	65	28	41	3 FORI/HOLES
17136	75	48	83	82	50	73	6 FORI/HOLES

TAPPO CON FILTRO E CESTELLO A SILDARE

BOUCHON AVEC FILTRE
 WELDABLECAP WITH FILTER AND BASKET
 ÖLFILTER
 TAPÓN CON FILTRO Y CESTITO A SOLDAR

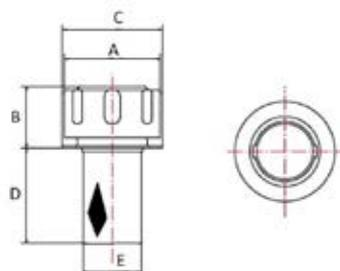

Art./Ref.	A mm	B mm	C mm	D mm	E mm
17137	75	48	84	105	38

SPIA OLIO IN ALLUMINIO

ALUMINIUM OIL LEVEL PLUG

INDICATEUR HUILE EN ALLUMINIUM

ALU - ÖLSCHAUGLAS

INDICADOR NIVEL ACEITE, DE ALUMINIO

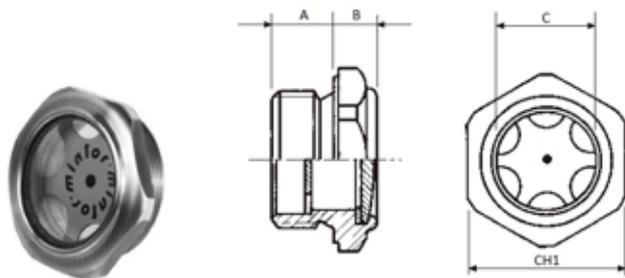

Art./Ref.	A mm	B mm	C mm	CH mm	Filettatura/Thread
31804	8	7	10	17	1/4"
31805	9	7	13	22	3/8"
31806	10	9	16	27	1/2"
31807	11	9	21	32	3/4"

MANOMETRO ALLA GLICERINA PER IMPIANTI OLEODINAMICI

MANOMETRE A BAIN DE GLICERINE

HYDRAULIC GLYCERINE MANOMETER

HYDRAULIK-MANOMETER MIT GLYZERINFÜLLUNG

MANOMETRO A LA GLICERINA PARA INSTRUMENTOS OLEOS



Art./Ref.	Filettatura/Thread	Note/Note	Tipo/Type
02768	1/4"	Ø 60	SCALA 0-160 bar
05289	1/4"	Ø 60	SCALA 0-250 bar
08012	1/4"	Ø 60	SCALA 0-400 bar

ESCLUSORE PER MANOMETRO

ROBINET PROTEGE-MANOMETRE

CUT OUT FOR MANOMETER

AUSSCHALTER FÜR MANOMETER

REGULADOR A DE MANÓMETRO

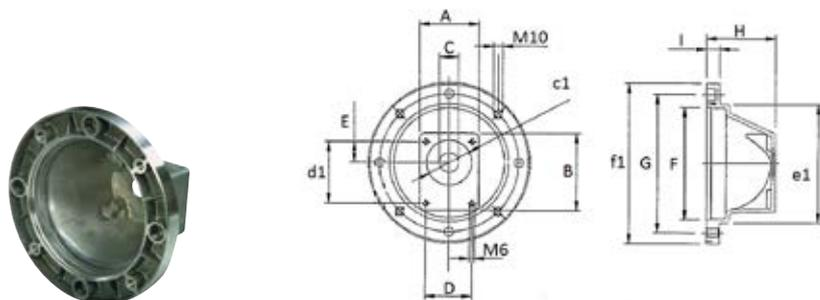

Art./Ref.	Filettatura/Thread	Tipo/Type
03231	1/4"	IN LINEA / LINEAR
03232	1/4"	90°

LANTERNA PER MOTORE ELETTRICO GRANDEZZA 80-90
LANTERNE POUR MOTEUR ÉLECTRIQUE TAILLE 80-90
FLANGE FOR ELECTRIC MOTOR FRAME 80-90
PUMPENTRÄGER FÜR EL. MOTOR BAUGRÖSSE 80-90
CAMPANA PARA MOTOR ELECTRICO TAMANO 80-90

Art./Ref.	A mm	B mm	C mm	c1	D mm	d1	E mm	e1	F mm	f1	G mm	H mm	I mm/l mm	Potenza HP/ HP power	Note/Note	Tipo/Type
09215	90	120	25,4	-	52	72	26,2	135	130	200	165	95	95	80 (0)	ART.09216	GRUPPO 1

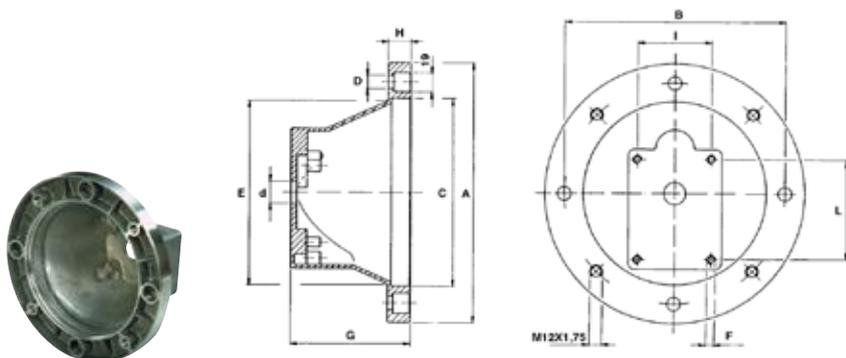
LANTERNA PER MOTORE ELETTRICO GRANDEZZA 100 - 112 - 132
LANTERNE POUR MOTEUR ÉLECTRIQUE TAILLE 100 - 112 - 132
FLANGE FOR ELECTRIC MOTOR FRAME 100-112 - 132
PUMPENTRÄGER FÜR EL. MOTOR BAUGRÖSSE 100-112 - 132
CAMPANA PARA MOTOR ELECTRICO TAMANO 100-112 - 132

Art./Ref.	A mm	B mm	C mm	c1	D mm	d1	E mm	e1	F mm	f1	G mm	H mm	I mm/l mm	Potenza HP/ HP power	Note/Note	Tipo/Type
02512	92	121	25,4	-	52	72	26,2	184	180	250	215	106	20	100 (ART.02489	GRUPPO 1
02498	92	121	36,5	67,5	71,5	96	32,5	184	180	250	215	106	20	100 (ART.02492	GRUPPO 2
17528	120	153	36,5	-	71,5	96	32,5	234	230	300	265	130	21	132 (ART.17526	GRUPPO 2
17527	120	153	50,8	-	98,5	128	42	234	230	300	265	130	21	132 (ART.17524	GRUPPO 3

GIUNTI ELASTICI PER POMPE AD INGRANAGGI E MOTORI ELETTRICI NORMALIZZATI UNEL/IEC

ACCOUPL. ÉLAS. POUR POMPES À ENGRENAGES ET MOTEURS ÉLECTRIQUES SELON NORMES UNEL/IEC

FLEXIBLE COUPLINGS FOR GEAR PUMP AND EL. MOTOR ACCORDING TO UNEL/IEC NORM

DREHELASTISCHE KUPPLUNGEN FÜR ZAHNRADPUMPEN UND E. MOTOREN NACH UNEL/IEC NORMEN

ACOPLAMENTO PARA BOMBA MECANIZADO CON JUNTA ELASTICA

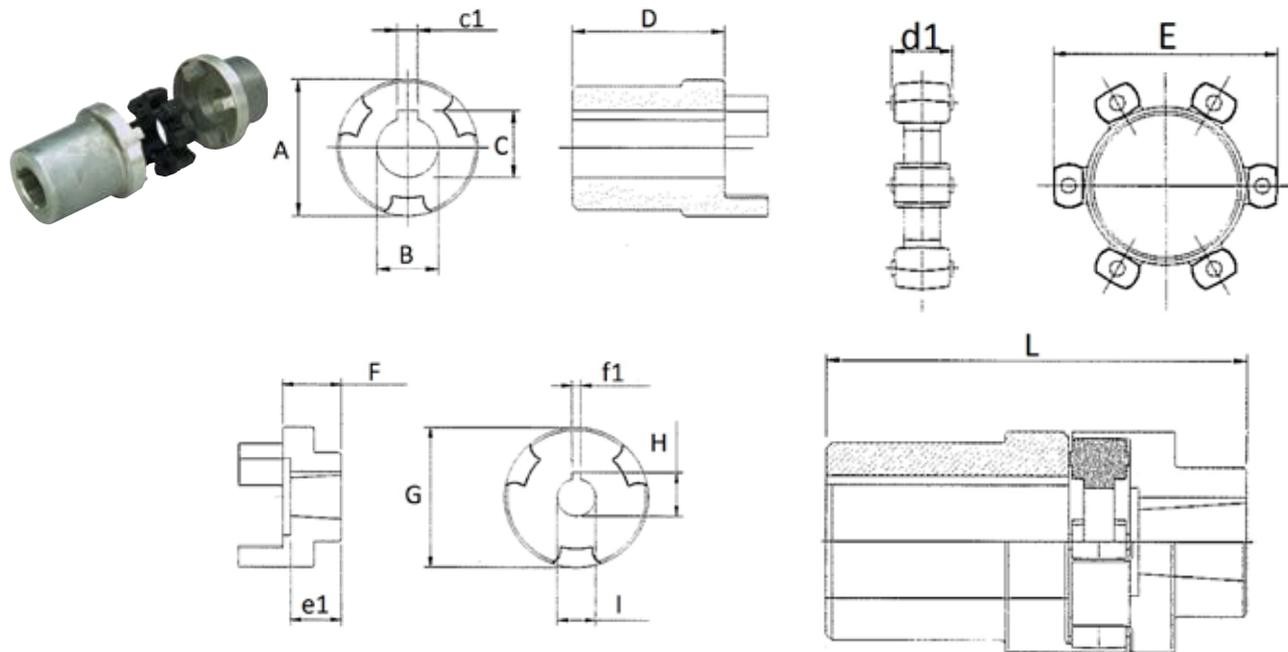

Art./Ref.	A mm	B mm	C mm	c1	D mm	d1	E mm	e1	F mm	f1	G mm	H mm	I mm/l mm	L mm	Tipo/Type
09216	45	24	27	8	50	16	45	14,8	23,3	2,4	45	10,5	9,7	89,3	GRUPPO 1
02489	55	28	31,3	8	60	18	55	14,5	21,5	2,4	55	10,5	9,7	99,5	GRUPPO 1
02492	55	28	31,3	8	60	18	55	22,5	21,5	3,2	55	18,5	17,36	99,5	GRUPPO 2
17526	74	38	41,3	10	80	20	74	22	22	3,2	74	18,5	17,36	122	GRUPPO 2
17524	74	38	41,4	10	80	20	74	28	23,5	4	74	23,6	22,2	123,5	GRUPPO 3

INSERTO ELASTICO

ELEMENT ELASTIQUE

FLEXIBLE INSERT

ELASTISCHES DRUCKELEMENT

JUNTA ELÁSTICA



Art./Ref.	Note/Note	Brand	Applicazione/Application
02502	ART. 09216/ART. 09216/ART. 09216/ART. 09216/ART. 09216	-	-
02500	ART. 02489 - 02492 - 09216/ART. 02489 - 02492 - 09216/ART. 02489 - 02492 - 09216/ART. 02489 - 02492 - 09216/ART. 02489 - 02492 - 09216	A.M.A.	02489, 02492
37213	ART. 17524 - 17526/ART. 17524 - 17526/ART. 17524 - 17526/ART. 17524 - 17526/ART. 17524 - 17526	A.M.A.	17524, 17526

FILTRI OLEODINAMICI IN ASPIRAZIONE CON ATTACCO FILETTATO
FILTRES HYDRAULIQUES EN ADMISSION AVEC FIXATION FILETÉE
SUCK-UP OIL FILTERS WITH THREADED CONNECTOR
ÖLFILTER AUF SAUGLEITUNG MIT GEWINDEANSCHLUSS
FILTRO ASPIRACIÓN

Art./Ref.	B mm	C mm	D mm	Filettatura/ Thread	Tipo/Type
02570	36	69	93	3/4"	30μ
17120	36	69	143	3/4"	30μ
17123	46	69	143	1"	30μ
02568	30	50	90	1/2"	60 μ
17118	30	69	93	1/2"	60μ
02579	36	69	93	3/4"	60 μ
17116	22	50	90	3/8"	-
02863	30	50	90	1/2"	90μ
17122	36	69	143	3/4"	90μ
17125	46	69	143	1"	90μ

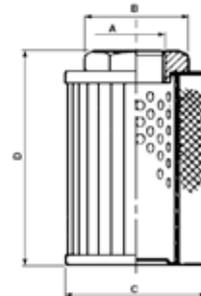
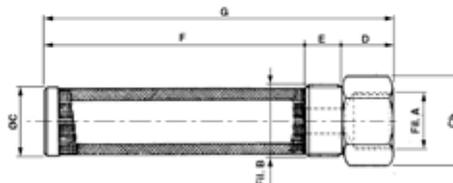
FILTRI ASPIRAZIONE AVVITABILI PER SPACCALEGNA
FILTRE ASPIRATIONE A VISSER
SCREWING SUSTION FILTERS FOR WOOD CUTTER
ANSAUG FILTER ZUM ANSCHRAUBEN FÜR HOLZSPALTER
FILTRO ASPIRACIÓN PARA MAQUINAS SERRADORAS

Art./Ref.	A mm	B mm	C mm	D mm	E mm	F mm	G mm	CH mm	Tipo/Type
03235	1/2"	3/4"	21	23	14	112	149	30	230/250μ
03236	1/2"	1"	30	29	16	100	145	40	250/270μ
03237	1/2"	1"	30	29	16	160	205	40	250/270μ
03238	3/4"	1"	30	29	16	120	165	40	250/270μ
03239	3/4"	1"	30	29	16	120	165	40	90/110μ

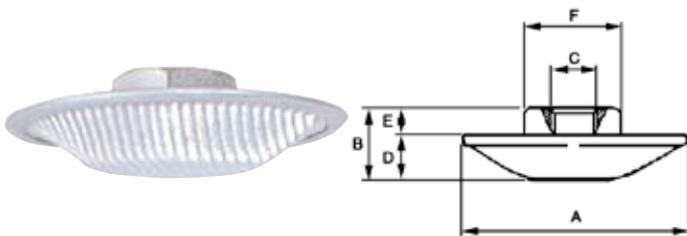
FILTRI OLEODINAMICI IN ASPIRAZIONE CON ATTACCO FILETTATO
FILTRES HYDRAULIQUES EN ADMISSION AVEC FIXATION FILETÉE
SUCK-UP OIL FILTERS WITH THREADED CONNECTOR
ÖLFILTER AUF SAUGLEITUNG MIT GEWINDEANSCHLUSS
FILTRO DE ASPIRACIÓN SUMERCIDO ROSCADO

Art./Ref.	A mm	B mm	C mm	D mm	E mm	F mm	Note/Note	Tipo/Type
17127	63	18	3/8"	10	8	22	10 LITRI/MIN.	90μ
17128	63	18	3/8"	10	8	22	12 LITRI/MIN./12 LITRI	250μ

FILTRI OLEODINAMICI SEMI IMMERSI DA MONTARE SUL RITORNO IN BASSA PRESSIONE

FILTRES HYDRAULIQUES SEMI PLONGÉS A MONTER SUR LA LIGNE DE RETOUR

HYDRAULIC SEMI-SUBMERGED OIL FILTERS TO BE FITTED ON A LOW PRESSURE

ÖLFILTER, HALBEINGETAUCHT IM TANK MONTIERT, AUF RUCKFLUSSLINIE MIT NIEDERDRUCK

FILTROS OLEODINAMICOS SEMISUMERGIDOS PARA RETORNOS DE BASA PRESIÓN

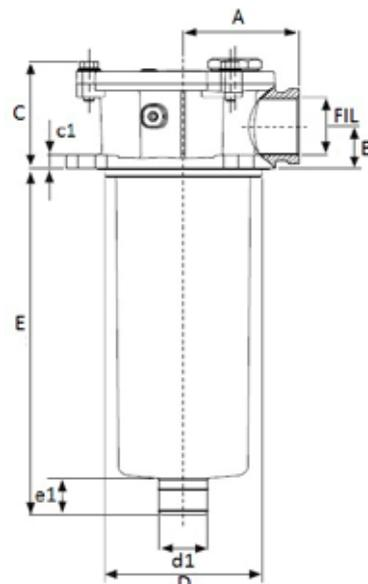
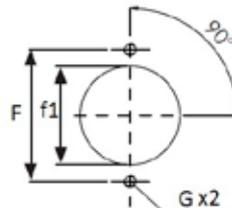
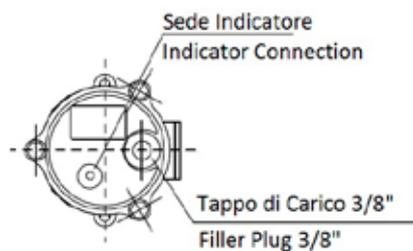

Art./Ref.	Filettatura/ Thread	A mm	B mm	C mm	c1	D mm	d1	E mm	e1	F mm	f1	G mm	Note/Note	Tipo/Type
02538	1/2"	51	25	60	8	67	24	82	22	89	67,5	M6	25 LITRI/MIN.	30μ
02539	1/2"	67	28,5	73	11	87	28	106	24	115	88,5	M8	42 LITRI/MIN.	30μ
17140	3/4"	67	28,5	73	11	87	28	106	24	115	88,5	M8	48 LITRI/MIN.	30μ
02540	3/4"	67	28,5	73	11	87	28	151	24	115	88,5	M8	62 LITRI/MIN.	30μ
02541	1"	67	28,5	73	11	87	28	151	24	115	88,5	M8	72 LITRI/MIN.	30μ
02542	1/2"	51	25	60	8	67	24	82	22	89	67,5	M6	30 LITRI/MIN.	60μ
02543	1/2"	67	28,5	73	11	87	24	106	24	115	88,5	M8	50 LITRI/MIN.	60μ
17141	3/4"	67	28,5	73	11	87	28	106	24	115	88,5	M8	60 LITRI/MIN.	60μ
02544	3/4"	67	28,5	73	11	87	28	151	24	115	88,5	M8	80 LITRI/MIN.	60μ
02545	1"	67	28,5	73	11	87	28	151	24	115	88,5	M8	100 LITRI/MIN.	60μ
17143	1/2"	51	25	60	11	67	24	82	22	89	67,5	M6	35 LITRI/MIN.	90μ
17144	1/2"	67	28,5	73	11	87	28	106	24	115	88,5	M8	60 LITRI/MIN.	90μ
17142	3/4"	67	28,5	73	11	87	28	106	24	115	88,5	M8	70 LITRI/MIN.	90μ
17145	3/4"	67	28,5	73	11	87	28	151	24	115	88,5	M8	90 LITRI/MIN.	90μ
17146	1"	67	28,5	73	11	87	28	151	24	115	88,5	M8	110 LITRI/MIN.	90μ

CARTUCCIA A RICAMBIO 30 M

CARTOUCHE A RECHANGE 30 M

SPARE CARTRIDGE 30 M

ERSATZ - EINSATZ 30 M

CARTUCHO DE RECAMBIO 30 M



Art./Ref.	Note/Note	Tipo/Type
02560	ART. 02538	30μ
02561	ART. 02539	30μ
02562	ART. 02540	30μ

CARTUCCIA A RICAMBIO 60 M

CARTOUCHE A RECHANGE 60 M
 SPARE CARTRIDGE 60 M
 ERSATZ - EINSATZ 60 M
 CARTUCHO DE RECAMBIO 60 M

Art./Ref.	Note/Note	Tipo/Type
02564	ART. 02542	60 μ
02565	ART. 02543	60 μ
02566	ART. 02544	60 μ



CARTUCCIA A RICAMBIO 90 M

CARTOUCHE A RECHANGE 90 M
 SPARE CARTRIDGE 90 M
 ERSATZ - EINSATZ 90 M
 CARTUCHO DE RECAMBIO 90 M

Art./Ref.	Note/Note
17147	ART. 17143
17148	ART. 17144
17149	ART. 17145

FILTRI OLEODINAMICI IN LINEA "SPIN-ON" CON CARTUCCIA AVVITABILE A PERDERE

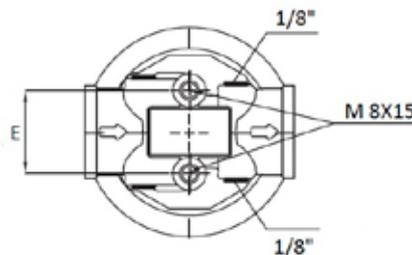
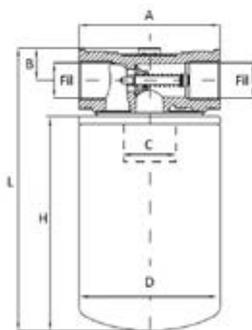
FILTRES HYDRAULIQUES "SPIN-ON" AVEC CARTOUCHE
 OIL FILTERS "SPIN-ON" WITH THROW AWAY CARTRIDGE
 FILTER "SPIN-ON" IN DER SAUG-UND RÜCKLAUFLEITUNG EINZUBAUEN
 FILTRO EN LINEA "SPIN - ON" CON CARTUCHO DE RECAMBIO



Art./Ref.	A mm	B mm	C mm	D mm	E mm	Filettatura/ Thread	H mm	L mm	Note/Note	Tipo/Type
03240	95	22	3/4"	96	38	3/4"	148	192	ASPIRAZIONE / SUCTION	10μ
03241	95	22	3/4"	96	38	3/4"	148	192	ASPIRAZIONE / SUCTION	25μ
03242	95	22	3/4"	96	38	3/4"	148	192	ASPIRAZIONE / SUCTION	60μ
03243	95	22	3/4"	96	38	3/4"	148	192	ASPIRAZIONE / SUCTION	125μ
03244	133	30	1"1/4"	128	50	1"1/4"	182	249	ASPIRAZIONE / SUCTION	10μ
03245	133	30	1"1/4"	128	50	1"1/4"	182	249	ASPIRAZIONE / SUCTION	25μ
03246	133	30	1"1/4"	128	50	1"1/4"	182	249	ASPIRAZIONE / SUCTION	60μ
03247	133	30	1"1/4"	128	50	1"1/4"	182	249	ASPIRAZIONE / SUCTION	125μ
03264	95	22	3/4"	96	38	3/4"	148	192	RITORNO / RETURN	10μ
03265	95	22	3/4"	96	38	3/4"	148	192	RITORNO / RETURN	25μ
03266	95	22	3/4"	96	38	3/4"	148	192	RITORNO / RETURN	60μ
03267	95	22	3/4"	96	38	3/4"	148	192	RITORNO / RETURN	125μ
03269	133	30	1"1/4"	128	50	1"1/4"	182	249	RITORNO / RETURN	10μ
03270	133	30	1"1/4"	128	50	1"1/4"	182	249	RITORNO / RETURN	25μ
03271	133	30	1"1/4"	128	50	1"1/4"	182	249	RITORNO / RETURN	60μ
03272	133	30	1"1/4"	128	50	1"1/4"	182	249	RITORNO / RETURN	125μ

CARTUCCIA A RICAMBIO

CARTOUCHE A RECHANGE
 SPARE CARTRIDGE
 ERSATZ - EINSATZ
 CARTUCHO DE RECAMBIO



Caratteristiche:

Scala: da 1 a 12 BAR
 Attacco: posteriore
 Filetto: 1/8"

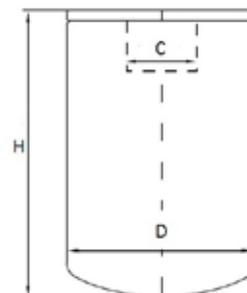

Art./Ref.	C mm	D mm	H mm	Note/Note	Tipo/Type
03248	3/4"	96	148	ART. 03240-03264	10μ
03249	3/4"	96	148	ART. 03241-03265	25μ
03250	3/4"	96	148	ART. 03242-03266	60μ
03251	3/4"	96	148	ART. 03243-03267	125μ
03252	1"1/4"	128	182	ART. 03244-03269	10μ
03253	1"1/4"	128	182	ART. 03245-03270	25μ
03254	1"1/4"	128	182	ART. 03246-03271	60μ
03255	1"1/4"	128	182	ART. 03247-03272	125μ

MANOMETRO PER "SPIN - ON"

MANOMETRE POUR "SPIN - ON"
 MANOMETER FOR "SPIN - ON" FILTER
 GLYCERIN MANOMETER FEUR "SPIN - ON" FILTER
 MANÓMETRO

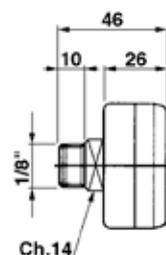
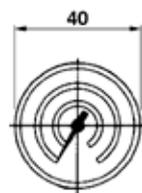

Art./Ref.
03256

TERMOSTATO PER SCAMBIATORE DI CALORE

THERMOSTAT POUR ECHANGEUR DE CHALEUR
 THERMAL SWITCH HEAT EXCHANGERS
 THERMOSTATE FUER WÄRMETAUSCHER
 TERMÓSTATO PARA INTERCAMBIADOR DE CALOR



Termostato per scambiatori di calore
Termal switch for heat exchangers

Art./Ref.	Volt/Volt	Brand	Applicazione/Application
84779	12VDC	A.M.A.	18375, 18376, 18378
84780	24VDC	A.M.A.	18374, 18377, 18379

SCAMBIATORI DI CALORE IN ALLUMINIO DA 10 A 80 LITRI

ECHANGEUR DE CHALEUR EN ALUMINIUM
ALUMINIUM HEAT EXCHANGERS
ALUMINIUM WÄRMETAUSCHER
INTERCAMBIADOR TÉRMICO DE ALUMINIO

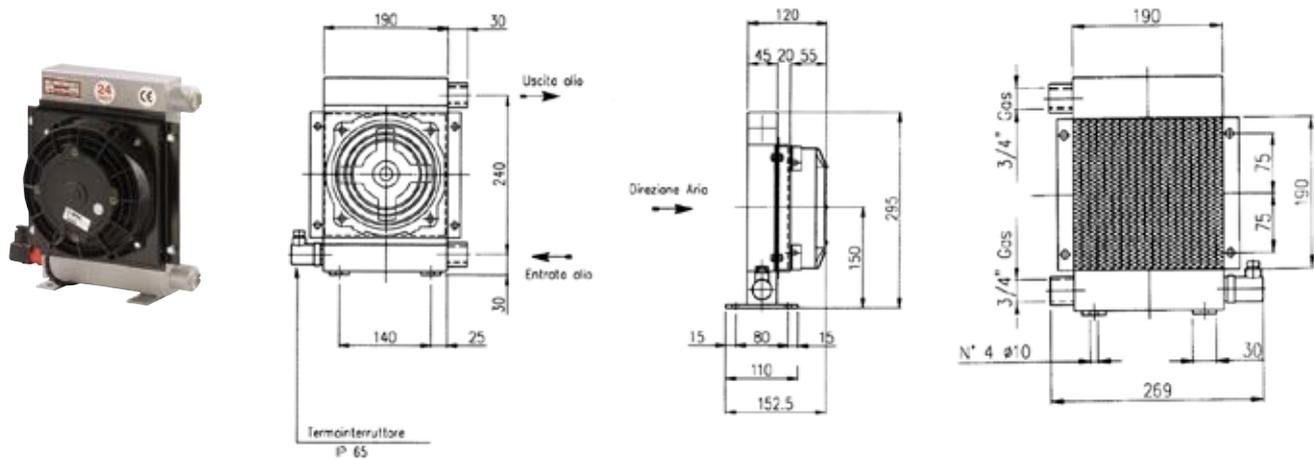
scambiatore di calore in alluminio da 10 a 80 litri (TERMOSTATO NON INCLUSO)

Art./Ref.	Pressione max (bar)/Pression max (bar)	Rotazione/Rotation	Note/Note	Volt/Volt
18374	27	SX/DX	PORTATA/FLOW 10/80 LITRI	24
18375	27	SX/DX	Termostato non incluso PORTATA/FLOW 10/80 LITRI	12

SCAMBIATORI DI CALORE IN ALLUMINIO DA 25 A 150 LITRI

ECHANGEUR DE CHALEUR EN ALUMINIUM
ALUMINIUM HEAT EXCHANGERS
WÄRMEAUSTAUSCHER AUS ALUMINIUM VON 25 BIS 150 LT
RADIADOR ALUMINIO LTS 25-250

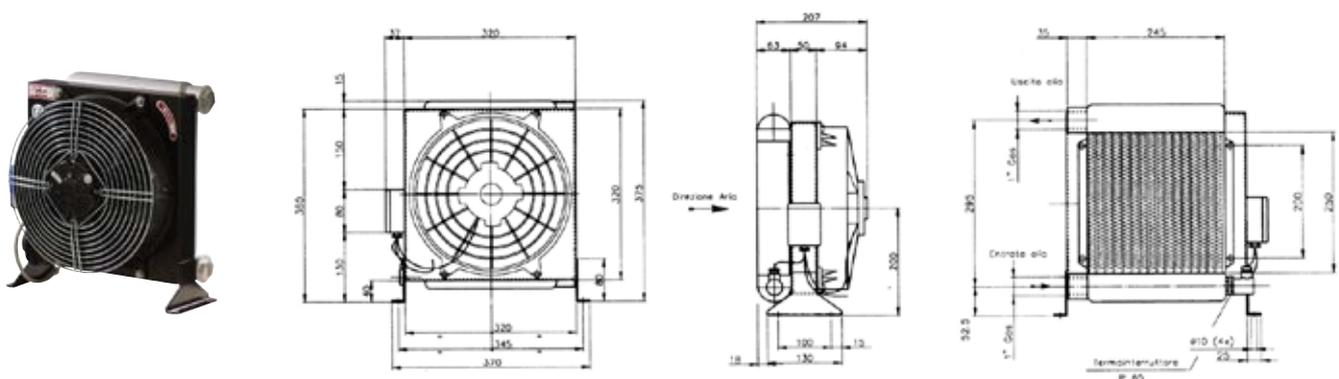
scambiatore di calore in alluminio da 25 a 150 litri (TERMOSTATO NON INCLUSO)

Art./Ref.	Pressione max (bar)/Pression max (bar)	Rotazione/Rotation	Note/Note	Volt/Volt
18377	27	SX/DX	PORTATA/FLOW 25/150 LITRI	24
18376	27	SX/DX	PORTATA/FLOW 25/150 LITRI	12

SCAMBIATORI DI CALORE IN ALLUMINIO DA 30 A 210 LITRI

ECHANGEUR DE CHALEUR EN ALUMINIUM

ALUMINIUM HEAT EXCHANGERS

ALUMINIUM WÄRMETAUSCHER

INTERCAMBIADOR TÉRMICO DE ALUMINIO

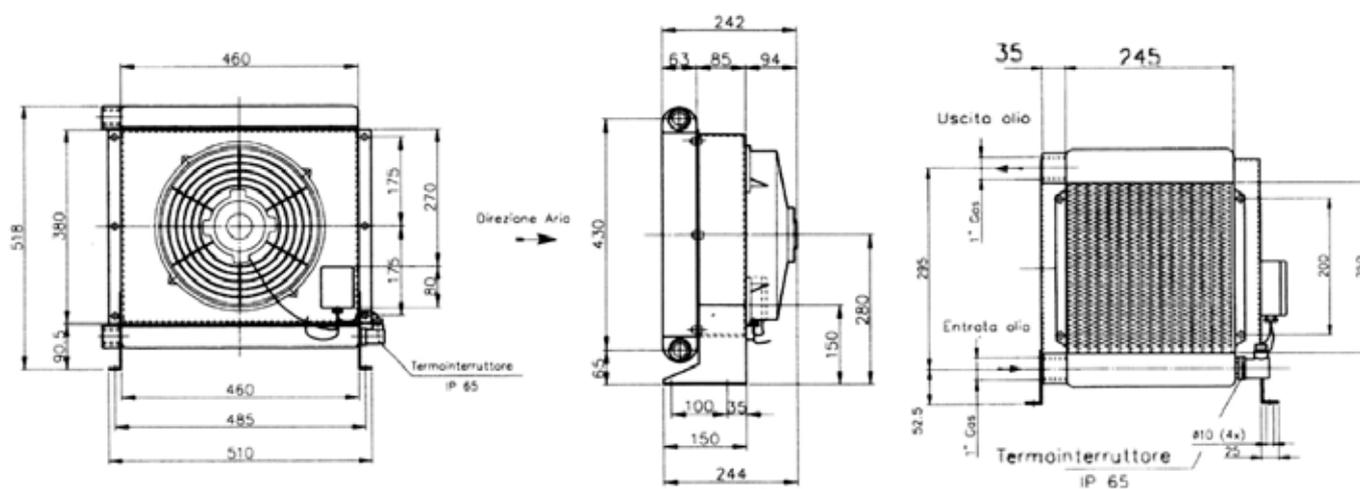

HEAT EXCHANGING EXCELLENCE SINCE 1919

scambiatore di calore in alluminio da 30 a 210 litri (THERMOSTATO NON INCLUSO)

Art./Ref.	Pressione max (bar)/Pression max (bar)	Rotazione/Rotation	Note/Note	Volt/Volt
18379	27	SX/DX	PORTATA/FLOW 30/210 LITRI	24
18378	27	SX/DX	PORTATA/FLOW 30/210 LITRI	12

1.2.5 Distributori, deviatori, elettrovalvole & valvole

Spool valves, diverters, electric valves & valves



Ricambi & accessori per macchine agricole

SPARE PARTS & ACCESSORIES FOR AGRICULTURAL MACHINE

Tutti gli articoli della presente sezione, prodotti da AMA SPA e/o da terzi per conto di AMA, sono adattabili ("non originali") alle marche indicate ai sensi di quanto previsto dal REG. CE n. 1400/2002. I diritti sui marchi citati appartengono ai legittimi proprietari ed il loro uso ha l'esclusiva finalità di consentire all'utilizzatore la comparazione dei diversi prodotti. All items of this section, manufactured by AMA SPA and/or any third party on behalf of AMA, are adaptable ("non-original") to the brands listed under the provisions of the REG. CE n. 1400/2002. The rights on the trademarks belong to their respective owners and their usage is only aimed to allow the user to compare different products.

DISTRIBUTORI

DISTRIBUTEURS
SPOOL VALVES
STEUERGERÄT
DISTRIBUIDORES

CARATTERISTICHE:

Sono distributori monoblocco in ghisa speciale concepiti in dimensioni ridotte al minimo per garantire una più facile applicazione senza per questo ridurre la resistenza alle elevate pressioni di esercizio.

Sono disponibili 6 modelli di produzione standard:

Tipo C - Distributore da 1 a 4 leve 70 litri da 1/2" con carry over (modello SD11)

Tipo D - Distributore ad una leva 40 litri da 3/8" con deviatore per modifica circuito da semplice a doppio effetto e viceversa

Tipo F - Distributore ad una leva 40 litri da 3/8" senza carry over 40 litri da 3/8" (modello SD4)

Tipo G - Distributore da 1 a 6 leve 40 litri da 3/8" con carry over (modello SD5)

Tipo H - Distributore da 1 a 5 leve 40 litri da 3/8" con carry over (modello BASIC)

Tipo I - Distributore da 1 a 4 leve 70 litri da 1/2" con carry over (modello BASIC)

PROPERTIES :

Monobloc valves in special cast iron made, studied in smaller dimension, to give best performances at high working pressure.

6 models available

Item C - distributor with 1 to 4 levers 70 liters of 1/2" with carry over (modell SD11)

Item D - distributor with one lever 40 liters of 3/8" with deviator for circuit changing from single to double effect and reverse

Item F - distributor with 1 lever 40 liters of 3/8" without carry over and electric distributor 40 liters of 3/8" (modell SD4)

Item G - distributor with 1 to 6 lever of 40 liters of 3/8" with carry over (modell SD5)

Item H - distributor with 1 to 6 lever of 40 liters of 3/8" with carry over (BASIC modell)

Item I - distributor with 1 to 4 levers 70 liters of 1/2" with carry over (BASIC model)

Tipo Type	Portata (lt/min) Flow (ft./min.)	Filetto (A-B) Thread (A-B)	Filetto (P-T) Thread (P-T)	Marca Brand	Modello Model
C	70	1/2"	1/2"- 3/4"	WALVOIL	SD11
D	40	3/8"	3/8"	WALVOIL	SD5
F	40	3/8"	3/8"	WALVOIL	SD4
G	40	3/8"	3/8"	WALVOIL	SD5
H	40	3/8"	3/8"	-	BASIC
I	70	1/2"	1/2"-3/4"	-	BASIC

DISTRIBUTORE MONOBLOCCO DA 1 A 6 LEVE DA 3/8" TIPO G

DISTRIBUTEUR MONOBLOC DE 1 A 6 ELEM. 3/8 TYPE G
 MONOBLOC SPOOL VALVE FROM 1 TO 6 LEVERS TYPE G
 MONOBLOCK-STEUERGERAET 1 - 6 HEBEL 3/8" TYP G
 DISTRIBUIDOR MONOBLOQUE 1-6 PALANCAS 3/8" TIPO G

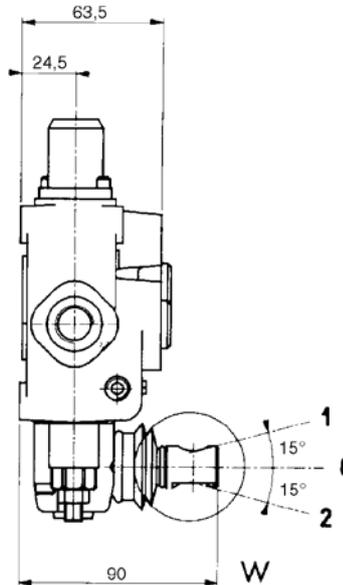
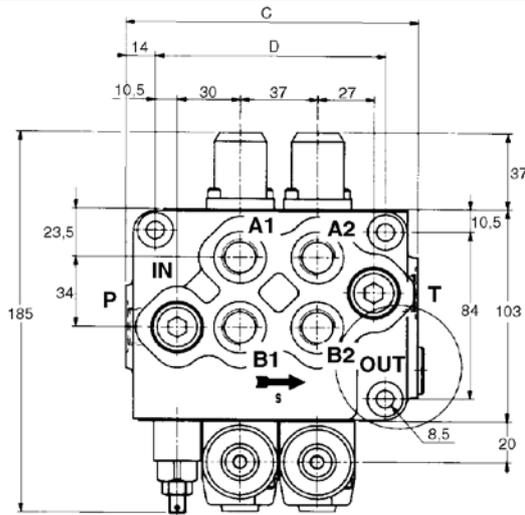

TIPO / TYPE	C (mm)	D (mm)
1 LEVA / 1 LEVER	100,5	73
2 LEVE / 2 LEVERS	137,5	110
3 LEVE / 3 LEVERS	174,5	147
4 LEVE / 4 LEVERS	211,5	184
5 LEVE / 5 LEVERS	248,5	221
6 LEVE / 6 LEVERS	285,5	258

DISTRIBUTORE MONOBLOCCO DA 1 A 6 LEVE DA 3/8" TIPO H (BASIC)

DISTRIBUTEUR MONOBLOC DE 1 A 4 ELEM. 1/2' TYPE C
 MONOBLOC SPOOL VALVE FROM 1 TO 6 LEVERS TYPE H (BASIC LINE)
 MONOBLOCK-STEUERGERAET 1 - 6 HEBEL 3/8" TYP H (BASIC)
 DISTRIBUIDOR MONOBLOQUE 1-6 PALANCAS 3/8" TIPO H (BÁSICO)

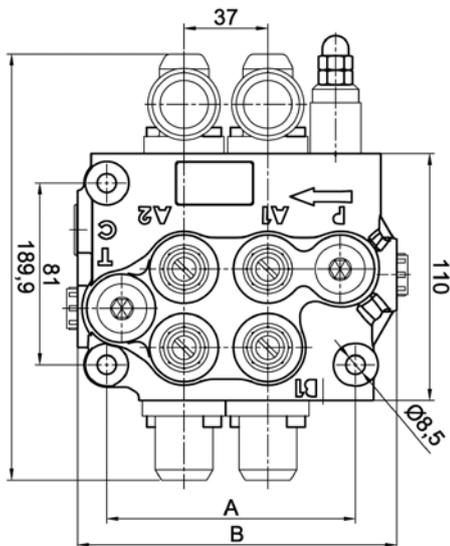

Tipo/Type	A (mm)	B (mm)
1 LEVA / 1 LEVER	73	104
2 LEVE / 2 LEVERS	110	141
3 LEVE / 3 LEVERS	147	178
4 LEVE / 4 LEVERS	184	215
5 LEVE / 5 LEVERS	221	252
6 LEVE / 6 LEVERS	258	289

DISTRIBUTORE MONOBLOCCO DA 1 A 4 LEVE DA 1/2" TIPO C

DISTRIBUTEUR MONOBLOC DE 1 A 4 ELEM. 1/2" TYPE C
 MONOBLOC SPOOL VALVE FROM 1 TO 4 LEVERS 1/2" TYPE C
 MONOBLOCK-STEUERGERAET 1 - 4 HEBEL 1/2" TYP C
 DISTRIBUIDOR MONOBLOQUE 1-4 PALANCAS 1/2" TIPO C

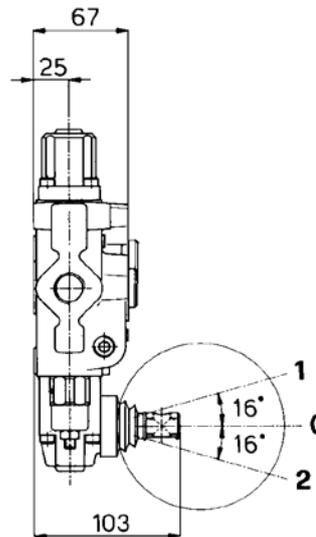
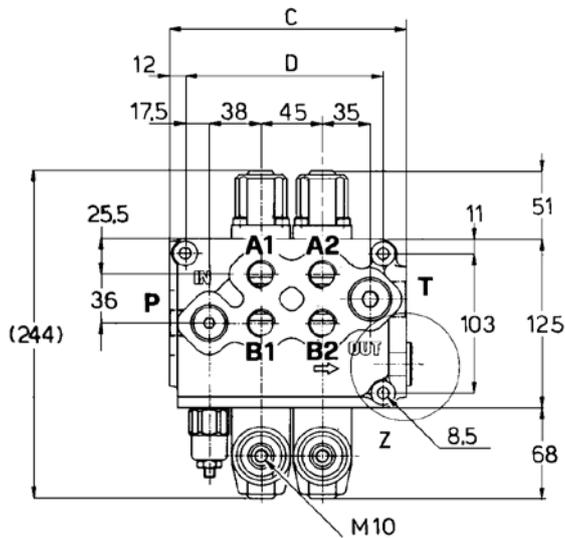

Tipo/Type	C (mm)	D (mm)
1 LEVA / 1 LEVER	130	100
2 LEVE / 2 LEVERS	174,5	145
3 LEVE / 3 LEVERS	219,5	190
4 LEVE / 4 LEVERS	264,5	235

DISTRIBUTORE MONOBLOCCO DA 1 A 3 LEVE DA 1/2" TIPO I (BASIC)

DISTRIBUTEUR MONOBLOC DE 1 A 3 ELEM. 1/2" TYPE I (BASIC)
 MONOBLOC SPOOL VALVE FROM 1 TO 3 LEVERS 1/2" TYPE I (BASIC LINE)
 MONOBLOCK-STEUERGERAET 1 - 3 HEBEL 1/2" TYP I (BASIC)
 DISTRIBUIDOR MONOBLOQUE 1-3 PALANCAS 1/2" TIPO I (BÁSICO)

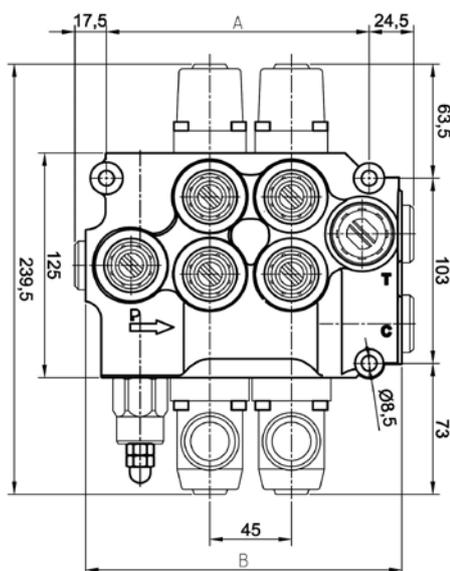

Tipo/Type	A (mm)	B (mm)
1 LEVA / 1 LEVER	100	129,5
2 LEVE / 2 LEVERS	145	174,5
3 LEVE / 3 LEVERS	190	219,5

DISTRIBUTORI A 1 LEVA
DISTRIBUTEURS A 1 ELEMENTS
1 LEVERS DISTRIBUTORS
1 HEBEL STEUERGERÄT
DISTRIBUIDORES DE 1 PALANCAS

Art./ Ref.	Modello/ Model	Tipo/ Type	Circuito/ Circuit	Pressione max (bar)/ Pression max (bar)	Capacità LT/ Capacity LT	Filettatura interna/ Inner Thread	Schema Circuito/ Schema Circuito	Schema Posizione/ Thickness	Note/Note
05735	SD4	F	SEMPLICE EFFETTO / SINGLE ACTING	180	40	3/8"			STANDARD
75981	SD4	F	SEMPLICE EFFETTO / SINGLE ACTING	180	40	3/8"			RITENUTA POS.1/DEDUCTION POS.1
05736	SD4	F	DOPPIO EFFETTO / DOUBLE ACTING	180	40	3/8"			STANDARD
75982	SD4	F	DOPPIO EFFETTO / DOUBLE ACTING	180	40	3/8"			RITENUTA POS.1/DEDUCTION POS.1
75983	SD4	F	DOPPIO EFFETTO / DOUBLE ACTING	180	40	3/8"			RITENUTA POS.1-2/DEDUCTION POS.1-2
76077	SD4	F	DOPPIO EFFETTO / DOUBLE ACTING	180	40	3/8"			RITORNO POS.1 PER SPACCALEGNA/DEDUCTION POS.1 WOODSPLITTER
83970	BASIC	H	DOPPIO EFFETTO / DOUBLE ACTING	180	40	3/8"			RITORNO POS.1 PER SPACCALEGNA CON TASTATORE/DEDUCTION POS.1 WOODSPLITTER WITH BALL
76078	SD4	F	DOPPIO EFFETTO / DOUBLE ACTING	180	40	3/8"			MOTORI ORBITALI/ORBITROL MOTORS
05738	SD5	G	SEMPLICE EFFETTO / SINGLE ACTING	180	45	3/8"			STANDARD
05739	SD5	G	DOPPIO EFFETTO / DOUBLE ACTING	180	45	3/8"			STANDARD
76079	SD5	G	DOPPIO EFFETTO / DOUBLE ACTING	180	45	3/8"			FLOTTANTE / FLOATING
80790	SD5	-	DOPPIO EFFETTO / DOUBLE ACTING	180	45	3/8"		-	ROTATIVO GRUPPO LEVA ARTICOLO 84749 ROTATIVE LEVER CODE 84749
03548	SD5	D	SEMPLICE EFFETTO / SINGLE ACTING DOPPIO EFFETTO / DOUBLE ACTING	180	45	3/8"	 	 	STANDARD
61402	BASIC	H	SEMPLICE EFFETTO / SINGLE ACTING	180	40	3/8"			STANDARD
58270	Basic	H	DOPPIO EFFETTO / DOUBLE ACTING	180	40	3/8"			STANDARD

Art./ Ref.	Modello/ Model	Tipo/ Type	Circuito/ Circuit	Pressione max (bar)/ Pression max (bar)	Capacità LT/ Capacity LT	Filettatura interna/ Inner Thread	Schema Circuito/ Schema Circuito	Schema Posizione/ Thickness	Note/Note
05181	SD11	C	DOPPIO EFFETTO / DOUBLE ACTING	180	70	1/2"-3/4"			STANDARD
05182	SD11	C	SEMPLICE EFFETTO / SINGLE ACTING	180	70	1/2"-3/4"			STANDARD
17492	SD11	C	DOPPIO EFFETTO / DOUBLE ACTING	180	70	1/2"-3/4"			RITORNO POS.1 PER SPAC-CALEGNA/DEDUCTION POS.1 WOODSPLITTER
80791	SD11		DOPPIO EFFETTO / DOUBLE ACTING	180	70	1/2"-3/4"		-	ROTATIVO GRUPPO LEVA ARTICOLO 84749 ROTATIVE LEVER CODE 84749
58276	Basic	I	DOPPIO EFFETTO / DOUBLE ACTING	180	80	1/2"-3/4"			STANDARD

DISTRIBUTORI A 2 LEVE

DISTRIBUTEURS A 2 ELEMENTS
TWO LEVERS DISTRIBUTORS
2 HEBEL STEUERGERÄT
DISTRIBUIDORES DE 2 PALANCAS



Art./ Ref.	Modello/ Model	Tipo/ Type	Circuito/Circuit	Pressione max (bar)/ Pression max (bar)	Capacità LT/ Capacity LT	Filettatura interna/ Inner Thread	Schema Circuito/ Schema Circuito	Schema Posizione/ Thickness	Note/Note
05743	SD5	G	1ª SEMPLICE EFFETTO / SINGLE ACTING 2ª DOPPIO EFFETTO / DOUBLE ACTING	180	45	3/8"			STANDARD
05744	SD5	G	1ª / 2ª DOPPIO EFFETTO / DOUBLE ACTING	180	45	3/8"			STANDARD
58503	SD5	G	1ª DOPPIO EFFETTO / DOUBLE ACTING 2ª DOPPIO EFFETTO FLOTTANTE / DOUBLE ACTING FLOATING	180	45	3/8"			2ª FLOTTANTE / 2ª FLOATING
61403	BASIC	H	1ª SEMPLICE EFFETTO / SINGLE ACTING 2ª DOPPIO EFFETTO / DOUBLE ACTING	180	40	3/8"			STANDARD
58271	BASIC	H	1ª / 2ª DOPPIO EFFETTO / DOUBLE ACTING	180	40	3/8"			STANDARD
02467	SD11	C	1ª SEMPLICE EFFETTO / SINGLE ACTING 2ª DOPPIO EFFETTO / DOUBLE ACTING	180	70	1/2"-3/4"			STANDARD
01975	SD11	C	1ª / 2ª DOPPIO EFFETTO / DOUBLE ACTING	180	70	1/2"-3/4"			STANDARD
58277	BASIC	I	1ª / 2ª DOPPIO EFFETTO / DOUBLE ACTING	180	80	1/2"-3/4"			STANDARD

DISTRIBUTORI A 3 LEVE
DISTRIBUTEURS A 3 ELEMENTS
THREE LEVERS DISTRIBUTORS
3 HEBEL STEUERGERÄT
DESTRIBUIDORES DE 3 PALANCAS

Art./ Ref.	Modello/ Model	Tipo/ Type	Circuito/ Circuit	Pressione max (bar)/ Pression max (bar)	Capacità LT/ Capacity LT	Filettatura interna/ Inner Thread	Schema Circuito/ Schema Circuito	Schema Posizione/ Thickness	Note/Note
05745	SD5	G	1ª / 2ª / 3ª DOPPIO EFFETTO / DOUBLE ACTING	180	45	3/8"			STANDARD
76087	SD5	G	1ª / 2ª DOPPIO EFFETTO / DOUBLE ACTING 3ª SEMPLICE EFFETTO / SINGLE ACTING	180	45	3/8"			STANDARD
58504	SD5	G	1ª / 2ª DOPPIO EFFETTO / DOUBLE ACTING 3ª DOPPIO EFFETTO FLOTTANTE / DOUBLE ACTING FLOATING	180	45	3/8"			3ª FLOTTANTE / 3ª FLOATING
61404	BASIC	H	1ª / 2ª DOPPIO EFFETTO / DOUBLE ACTING 3ª SEMPLICE EFFETTO / SINGLE ACTING	180	40	3/8"			STANDARD
58272	BASIC	H	1ª / 2ª / 3ª DOPPIO EFFETTO / DOUBLE ACTING	180	40	3/8"			STANDARD
08013	SD11	C	1ª / 2ª / 3ª DOPPIO EFFETTO / DOUBLE ACTING	180	70	1/2"-3/4"			STANDARD
58278	BASIC	I	1ª / 2ª / 3ª DOPPIO EFFETTO / DOUBLE ACTING	180	80	1/2"-3/4"			STANDARD

DISTRIBUTORI A 4 LEVE

DISTRIBUTEURS A 4 ELEMENTS

FOUR LEVERS DISTRIBUTORS

4 HEBEL STEUERGERÄT

DESTRIBUIDORES DE 4 PALANCAS



Art./Ref.	Modello/Model	Tipo/Type	Circuito/Circuit	Pressione max (bar)/Pression max (bar)	Capacità LT/Capacity LT	Filettatura interna/Inner Thread	Schema Circuito/Schema Circuito	Schema Posizione/Thickness	Note/Note
05746	SD5	G	1 ^a / 2 ^a / 3 ^a / 4 ^a DOPPIO EFFETTO / DOUBLE ACTING	180	45	3/8"			STANDARD
58505	SD5	G	1 ^a / 2 ^a / 3 ^a DOPPIO EFFETTO / DOUBLE ACTING 4 ^a DOPPIO EFFETTO FLOTTANTE / DOUBLE ACTING FLOATING	180	45	3/8"			4 ^a FLOTTANTE / 4 ^a FLOATING
58273	BASIC	H	1 ^a / 2 ^a / 3 ^a / 4 ^a DOPPIO EFFETTO / DOUBLE ACTING	180	40	3/8"			STANDARD
08122	SD11	C	1 ^a / 2 ^a / 3 ^a / 4 ^a DOPPIO EFFETTO / DOUBLE ACTING	180	70	1/2"-3/4"			STANDARD

DISTRIBUTORE A 5 LEVE

DISTRIBUTEURS A 5 ELEMENTS

FIVE LEVERS DISTRIBUTORS

5 HEBEL STEUERGERÄT

DISTRIBUIDORES DE 5 PALANCAS



Art./Ref.	Modello/Model	Tipo/Type	Circuito/Circuit	Pressione max (bar)/Pression max (bar)	Capacità LT/Capacity LT	Filettatura interna/Inner Thread	Schema Circuito/Schema Circuito	Schema Posizione/Thickness	Note/Note
12533	SD5	G	1 ^a / 2 ^a / 3 ^a / 4 ^a / 5 ^a DOPPIO EFFETTO / DOUBLE ACTING	180	45	3/8"			STANDARD
58274	BASIC	H	1 ^a / 2 ^a / 3 ^a / 4 ^a / 5 ^a DOPPIO EFFETTO / DOUBLE ACTING	180	40	3/8"			STANDARD

DISTRIBUTORE A 6 LEVE

DISTRIBUTEURS A 6 ELEMENTS
SIX LEVERS DISTRIBUTORS
6 HEBEL STEUERGERÄT
DISTRIBUIDORES DE 6 PALANCAS



Art./Ref.	Modello/Model	Tipo/Type	Circuito/Circuit	Pressione max (bar)/ Pression max (bar)	Capacità LT/ Capacity LT	Filettatura interna/ Inner Thread	Schema Circuito/Sche- ma Circuito	Schema Posizione/ Thickness	Note/Note
12534	SD5	G	1ª / 2ª / 3ª / 4ª / 5ª / 6ª DOPPIO EFFETTO / DOUBLE ACTING	180	45	3/8"			STANDARD
58275	BASIC	H	1ª / 2ª / 3ª / 4ª / 5ª / 6ª DOPPIO EFFETTO / DOUBLE ACTING	180	40	3/8"			STANDARD

DISTRIBUTORI COMPLETI DI LEVA CLOCHE

DISTRIBUTEURS AVEC LEVIER CLOCHE
DISTRIBUTORS COMPLETE WITH CLOCHE LEVER
STEUERGERÄTE KOMPLETT MIT CLOCHEHEBEL
DISTRIBUIDORES CON PALANCA TIPO JOISTIC

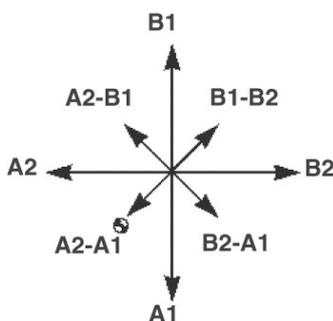

Art./Ref.	Modello/Model	Circuito/Circuit	Pressione max (bar)/ Pression max (bar)	Capacità LT/ Capacity LT	Filettatura interna/ Inner Thread	Schema Circuito/ Schema Circuito	Schema Posizione/ Thickness
03780	SD5	1ª SEMPLICE EFFETTO / SINGLE ACTING 2ª DOPPIO EFFETTO DOUBLE ACTING	180	45	3/8"		
03748	SD5	1ª / 2ª DOPPIO EFFETTO / DOUBLE ACTING	180	45	3/8"		
03749	SD5	1ª DOPPIO EFFETTO / DOUBLE ACTING / 2ª DOPPIO EFFETTO FLOTTANTE / DOUBLE ACTING FLOATING	180	45	3/8"		
03781	SD11	1ª SEMPLICE EFFETTO / SINGLE ACTING 2ª DOPPIO EFFETTO DOUBLE ACTING	180	70	1/2"-3/4"		
03750	SD11	1ª / 2ª DOPPIO EFFETTO / DOUBLE ACTING	180	70	1/2"-3/4"		
03751	SD11	1ª DOPPIO EFFETTO / DOUBLE ACTING 2ª DOPPIO EFFETTO FLOTTANTE / DOUBLE ACTING FLOATING	180	70	1/2"-3/4"		

DISTRIBUTORI COMPLETI DI LEVA CLOCHE CON TELECOMANDO

DISTRIBUTEUR AVEC LEVIER CLOCHE AVEC COMMANDE A DISTANCE
 SPOOL VALVE COMPLETE OF CLOCHE LEVER WITH REMOTE CONTROL
 STEUERGERÄTE KOMPLETT MIT CLOCHEHEBEL MIT FERNBEDIENUNG
 DISTRIBUITORES CON PALANCA JOISTIC CON TELECOMANDO

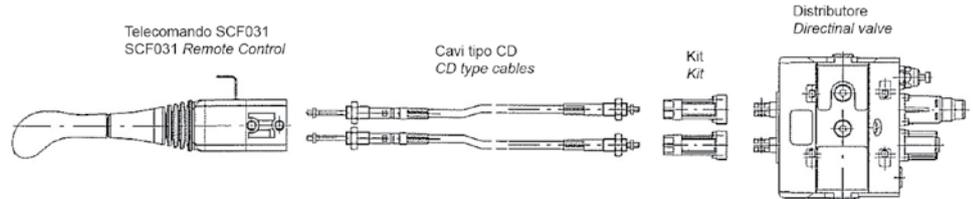

Art./ Ref.	Modello/ Model	Tipo/ Type	Circuito/Circuit	Pressione max (bar)/ Pression max (bar)	Capacità LT/ Capacity LT	Filettatura interna/ Inner Thread	Lunghezza mm/ Length mm	Schema Circuito/ Schema Circuito	Schema Posizione/ Thickness
78600	SD5	G	1ª / 2ª DOPPIO EFFETTO / DOUBLE ACTING	180	45	3/8"	1500		
78601	SD5	G	1ª SEMPLICE EFFETTO / SINGLE ACTING 2ª DOPPIO EFFETTO DOUBLE ACTING	180	45	3/8"	1500		
78602	SD5	G	1ª DOPPIO EFFETTO / DOUBLE ACTING / 2ª DOPPIO EFFETTO FLOTTANTE / DOUBLE ACTING FLOATING	180	45	3/8"	1500		
78603	SD11	C	1ª / 2ª DOPPIO EFFETTO / DOUBLE ACTING	180	70	1/2"-3/4"	1500		
78604	SD11	C	1ª DOPPIO EFFETTO / DOUBLE ACTING 2ª DOPPIO EFFETTO FLOTTANTE / DOUBLE ACTING FLOATING	180	70	1/2"-3/4"	1500		

LEVA TELECOMANDO

GROUPE DE COMMANDE
 PILOT RELAYING LEVER
 STEUERGRUPPE
 LEVA TELEMANDO

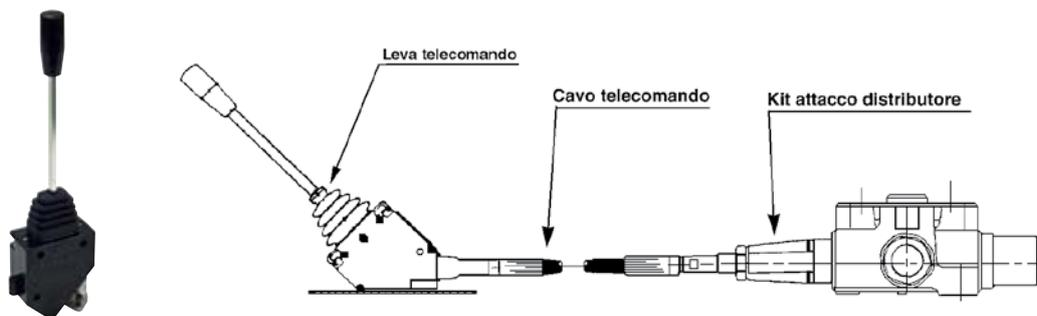

Art./Ref.	Brand	Applicazione/Application
37464	A.M.A.	18949, 18950, 18951, 18952, 18953, 18954, 18955

CAVO TELECOMANDO

CABLE TELECOMMANDE
PILOT RELAYING CABLE
KABEL
CABLE DEL TELEMANDO

Art./Ref.	Lunghezza mm/Lenght mm
18950	1500
18951	2000
18952	2500
18953	3000
18954	3500
18955	4000

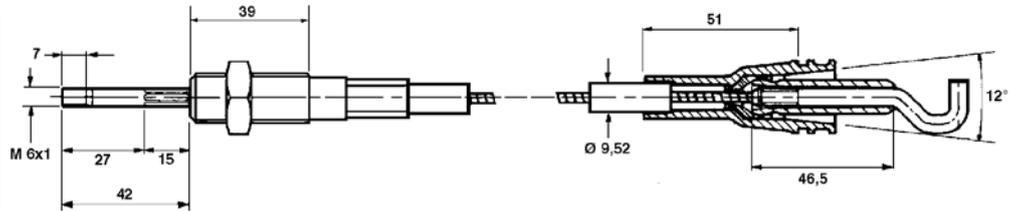

KIT APPLICAZIONE PER DISTRIBUTORE

KIT JONCTION POUR DISTRIBUTEUR
LINKAGE KIT
KUPPLUNGSSATZ
KIT DE APLICACIÓN PARA DISTRIBUIDOR

Art./Ref.	Modello/Model	Tipo/Type	Note/Note
08136	BM30-40-70 SD4-SD5 MD-ML BASIC	A,B,F,G,H	BLB WALVOIL DINOIL
08138	SD11 BASIC	C,I	WALVOIL
19432	AMI 300 M6	-	AMI

LEVA TELECOMANDO A CLOCHE

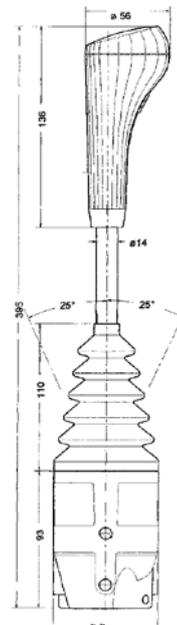
GROUPE DE COMMANDE A CLOCHE
CLOCHE PILOT RELAYING LEVER
CLOCHE STEUERGRUPPE
LEVA TELEMANDO TIPO JOYSTICK



Art./Ref.	Brand	Applicazione/Application
34236	A.M.A.	31758, 31759, 31760, 31761

LEVA TELECOMANDO CON BLOCCO

LEVE DE COMMANDE AVEC BLOQUE
 REMOTE CONTROL LEVER WITH BLOCK
 BLOCK STEUERGRUPPE
 LEVA TELEMANDO CON BLOQUEO

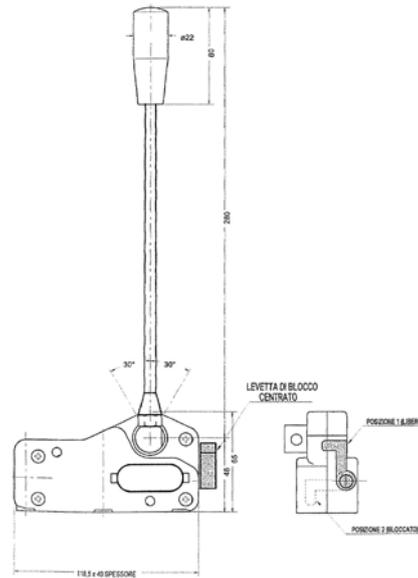

Art./Ref.	Brand	Applicazione/Application
31756	A.M.A.	31758, 31759, 31760, 31761

CAVO TELECOMANDO

CABLE TELECOMMANDE
 PILOT RELAYING CABLE
 KABEL
 CABLE DEL TELEMANDO

Art./Ref.	Lunghezza mm/Lenght mm
31758	1500
31759	2000
31760	2500
31761	3000

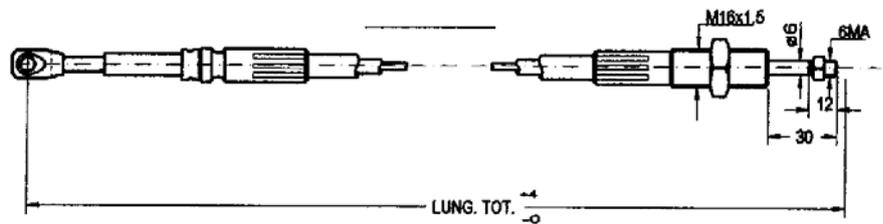

CAVO TELECOMANDO PER ROTOPRESSE

CABLE TELECOMMANDE POUR PRESSE A BALLEES RONDES
 PILOT RELAYING CABLE FOR VARIABLE CHAMBER BALERS
 KABEL FUER RUNDBALLNPRESSE
 CABLE DEL TELECOMANDO PARA ROTOEMPACADORAS



Art./Ref.	Lunghezza mm/Lenght mm
82623	3000
82624	3500

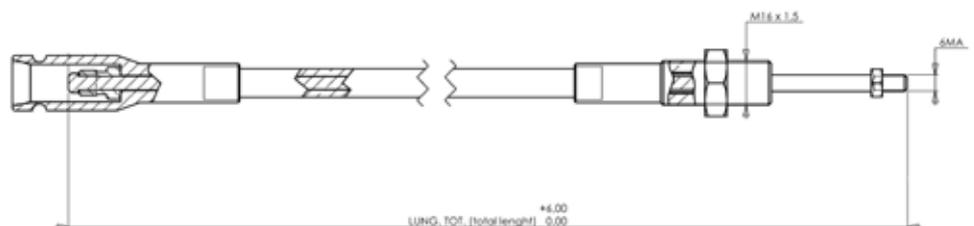

KIT TELECOMANDO A CLOCHE WALVOIL

KIT TELECOMMANDE A CLOCHE
 REMOTE CONTROL KIT (CLOCHE TYPE)
 "CLOCHE" FERNBEDIENUNGSATZ
 KIT TELEMANDO TIPO JOYSTICK



Art./Ref.	Note/Note	Brand	Applicazione/Application
16819	SD5	WALVOIL	TIPO/TYPE G (SD5)
16822	SD11	WALVOIL	TIPO/TYPE C. (SD11)

KIT TERMINALE AL TELECOMANDO WALVOIL

KIT TERMINAL TELECOMMANDE
 REMOTE CONTROL CONNECTION KIT
 KUPPLUNGSSATZ FÜR FERNBEDIENUNG
 KIT DE APLICATION PARA TELEMANDO



Art./Ref.	Note/Note	Brand	Applicazione/Application
16820	SD5	WALVOIL	TIPO/TYPE G (SD5)
16823	SD11	WALVOIL	TIPO/TYPE C. (SD11)

KIT TERMINALE AL DISTRIBUTORE WALVOIL

KIT TERMINAL DISTRIBUTEUR
 SPOOL VALVE CONNECTION KIT
 KUPPLUNGSSATZ FÜR FERNBEDIENUNG
 KIT APLICATION PARA DISTRIBUIDOR



Art./Ref.	Note/Note	Brand	Applicazione/Application
16821	SD5	WALVOIL	TIPO/TYPE G (SD5)
16824	SD11	WALVOIL	TIPO/TYPE C. (SD11)

CAVO TELECOMANDO WALVOIL

CABLE TELECOMMANDE
 PILOT RELAYING CABLE
 KABEL
 CABLE DEL TELEMANDO



Art./Ref.	Lunghezza mm/Lenght mm
03903	1000
12238	1250
03904	1500
89304	1750
03905	2000
03906	2500
03899	3000
19451	3500

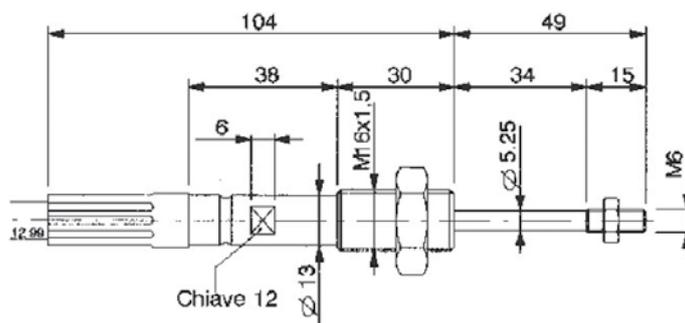

KIT LEVA A CLOCHE SENZA ASTA LEVA

CLOCHE LEVER KIT WITHOUT LEVER

CLOCHE LEVER KIT SANS LEVIER

KREUZ-SCHALTUNG OHNE HEBEL

PALANCA TIPO JOISTIC



Art./Ref.	Tipo/Type
16084	WALVOIL SD5 (3/8")
16085	WALVOIL SD11 (1/2")
73007	BASIC (3/8")

BUSSOLA PER LA CONTINUAZIONE DELLA LINEA DI PRESSIONE

DOUILLE POUR LA CONTINUATION DE LA LIGNE DE PRESSION

CARRY OVER BUSHING

DRUCKWEITERFÜHRUNGSBUCHSE

VALVULA PARA CONTINUACIÓN DE PRESIÓN



Art./Ref.	Tipo/Type
05200	WALVOIL SD5 (3/8")
63532	BASIC (3/8")
05201	WALVOIL SD11 (1/2")
76408	BASIC (1/2")
05198	DINOIL ML (3/8")

ASTA LEVA CON MICRO

LEVIER AVEC MICROCONTACT

LEVER SHAFT WITH MICRO

HEBEL MIT SCHALTER

PALANCA CON MICRO

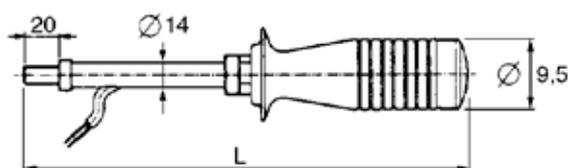
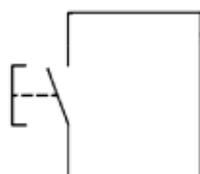

Art./Ref.	Filettatura esterna/External Thread	Lunghezza mm/Lenght mm	Note/Note
05881	M10	250	1 MICRO CON PULSANTE. 2 POS.IN CHIUSURA TENENDO PREMUTO (INSTABILE)/ 1 MICROSWITCH WITH PUSH-BUTTON (UNSTABLE)
05882	M12	250	1 MICRO CON PULSANTE. 2 POS.IN CHIUSURA TENENDO PREMUTO (INSTABILE)/ 1 MICROSWITCH WITH PUSH-BUTTON (UNSTABLE)

ASTA LEVA CON MICRO

LEVIER MICRO M10
HANDLE WITH MICROSWITCH
HEBEL MIT MIKROSCHALTER
PALANCA CON MICRO

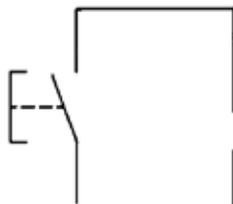
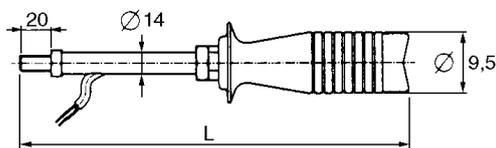

Art./Ref.	Filettatura esterna/External Thread	Lunghezza mm/Lenght mm	Note/Note
05883	M10	250	1 MICRO CON PULSANTE. 2 POS. CON AGGANCIO IN CHIUSURA PREMENDO IL PULSANTE (STABILE) / 1 MICROSWITCH WITH ROCKER SWITCH
05884	M12	250	1 MICRO CON PULSANTE. 2 POS. CON AGGANCIO IN CHIUSURA PREMENDO IL PULSANTE (STABILE) / 1 MICROSWITCH WITH ROCKER SWITCH

DISTRIBUTORI ELETTRICI (SD5)

DISTRIBUTEURS ELECTRIQUES
ELECTRIC DISTRIBUTORS
ELEKTRISCHES STEUERGERÄT
DISTRIBUIDORES ELECTRICOS



Art./Ref.	Modello/Model	Tipo/Type	Circuito/Circuit	Pressione max (bar)/Pression max (bar)	Capacità LT/Capacity LT	Filettatura interna/Inner Thread	Volt/Volt	Schema Circuito/Schema Circuito	Schema Posizione/Thickness
76081	SD5	G	DOPPIO EFFETTO / DOUBLE ACTING	150	45	3/8"	10,5 VDC (12VDC)		
76082	SD5	G	1 ^a / 2 ^a DOPPIO EFFETTO / DOUBLE ACTING	150	45	3/8"	10,5 VDC (12VDC)		
76083	SD5	G	1 ^a / 2 ^a / 3 ^a DOPPIO EFFETTO / DOUBLE ACTING	150	45	3/8"	10,5 VDC (12VDC)		
76084	SD5	G	1 ^a / 2 ^a / 3 ^a / 4 ^a DOPPIO EFFETTO / DOUBLE ACTING	150	45	3/8"	10,5 VDC (12VDC)		
76085	SD5	G	1 ^a / 2 ^a / 3 ^a / 4 ^a / 5 ^a DOPPIO EFFETTO / DOUBLE ACTING	150	45	3/8"	10,5 VDC (12VDC)		
76086	SD5	G	1 ^a / 2 ^a / 3 ^a / 4 ^a / 5 ^a / 6 ^a DOPPIO EFFETTO / DOUBLE ACTING	150	45	3/8"	10,5 VDC (12VDC)		

PULSANTIERE CON JOYSTICK PER DISTRIBUTORI ELETTRICI

TABLEAUX AVEC JOYSTICK POUR DISTRIBUTEURS

PUSH - BUTTON WITH JOYSTICK FOR ELECTRICAL VALVES

KABEL FERNSTEUERUNG MIT JOYSTICK FÜR EL STEUERGERÄTE

PULSADOR CON JOISTIC PARA DISTRIBUIDORES ELECTRICOS



Art./Ref.	Tipo/Type	Volt/Volt	Brand	Applicazione/Application
10983	1 JOYSTICH - 4 FUNZIONI/FUNCTION	12	A.M.A.	76082
10984	2 JOYSTICH - 4+2 FUNZIONI/FUNCTION	12	A.M.A.	76083
10985	2 JOYSTICH - 4 FUNZIONI/FUNCTION	12	A.M.A.	76084
10986	1 JOYSTICH - 2 FUNZIONI/FUNCTION	12	A.M.A.	76081
12171	3 JOYSTICH - 4+4+2 FUNZIONI/FUNCTION	12	A.M.A.	76085
12172	3 JOYSTICH - 4+4+4 FUNZIONI/FUNCTION	12	A.M.A.	76086

MANIPOLATORI A 2 E 4 FUNZIONI A RICAMBIO

MANIPOLATEURS 2 ET 4 FONCTIONS À RECHANGE

2 - 4 FUNCTIONS MANIPULATOR

KREUZSCHALTUNG 2 FNCH - 4 FANCH

MANIPULADOR REPUESTO CON 2 Y 4



Art./Ref.	Tipo/Type	Volt/Volt	Note/Note
12315	2 FUNZIONI/FUNCTION	12	MOLLA / SPRING
12316	2 FUNZIONI/FUNCTION	12	MANTENUTE / MOLD
12317	4 FUNZIONI/FUNCTION	12	MANTENUTE / MOLD
12318	4 FUNZIONI/FUNCTION	12	MOLLA / SPRING
12319	4 FUNZIONI/FUNCTION	12	1 MATENUTA/MOLD - 3 MOLLA/SPRING

CONNETTORE PER ELETTROVALVOLE

CONNECTEUR POUR CONTRÔLE DIRECTION

CONNECTOR FOR ELECTRIC VALVES

STECKER FÜR ELECTROVENTILEN

CONECTOR PARA ELECTROVÁLVULA



Art./Ref.	Volt/Volt	Note/Note
02939	12	SENZA/WITHOUT LED
19731	12	CON / WITH LED

IMPUGNATURE ERGONOMICHE

POIGNEE ERGONOMIQUE
 ERGONOMIC HANDLE
 ERGONOMISCHERGRUFF
 EMPUNADURA ERGONOMICA

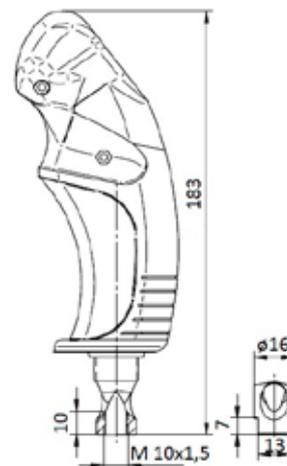

Art./Ref.	Modello/Model	Tipo/Type	Brand	Applicazione/Application
15866	2 PULSANTI / BUTTON	-	A.M.A.	27780, 27784, 27789, 76081
15867	3 PULSANTI / BUTTON	-	A.M.A.	27781, 27785
15868	4 PULSANTI / BUTTON	-	A.M.A.	27782, 27786, 76082
17082	2 PULSANTI / BUTTON	PULSANTE DI SICUREZZA/ SECURITY BUTTON	A.M.A.	27780, 27784, 27789, 76081
17083	4 PULSANTI / BUTTON	PULSANTE DI SICUREZZA/ SECURITY BUTTON	A.M.A.	27782, 27786, 76082
17084	6 PULSANTI / BUTTON	PULSANTE DI SICUREZZA/ SECURITY BUTTON	A.M.A.	76083

POSIZIONATORI PER DISTRIBUTORE

POSITIONNEURS POUR DISTRIBUTEURS
 DISTRIBUTORS SPOOLS CONTROL
 RASTUNGEN FÜR STEUERGERÄT
 POSICIONADORES PARA DISTRIBUIDORES



Art./Ref.	Tipo/Type	Note/Note
76088	RITORNO A MOLLA IN POS.0/ SPRING RETURN IN POS.0	WALVOIL TIPO/TYPER F (SD4)
05848	RITORNO A MOLLA IN POS.0/ SPRING RETURN IN POS.0	WALVOIL TIPO/TYPER G (SD5)
63531	RITORNO A MOLLA IN POS.0/ SPRING RETURN IN POS.0	BASIC TIPO/TYPER H (3/8")
05857	RITORNO A MOLLA IN POS.0/ SPRING RETURN IN POS.0	WALVOIL TIPO/TYPER C (SD11)
76096	RITENUTA POS.1/DEDUCTION POS.1	WALVOIL TIPO/TYPER F (SD4)
05849	RITENUTA POS.1/DEDUCTION POS.1	WALVOIL TIPO/TYPER G (SD5)
62177	RITENUTA POS.1/DEDUCTION POS.1	BASIC TIPO/TYPER H (3/8")
05859	RITENUTA POS.1/DEDUCTION POS.1 & RITENUTA POS.2/DEDUCTION POS.2	WALVOIL TIPO/TYPER C (SD11)
76409	RITENUTA POS.1/DEDUCTION POS.1	BASIC TIPO/TYPER I (1/2")
76089	RITENUTA POS.1e2/DEDUCTION POS.1&2	WALVOIL TIPO/TYPER F (SD4)
05850	RITENUTA POS.1e2/DEDUCTION POS.1&2	WALVOIL TIPO/TYPER G (SD5)
63530	RITENUTA POS.1e2/DEDUCTION POS.1&2	BASIC TIPO/TYPER H (3/8")
05861	RITENUTA POS.1e2/DEDUCTION POS.1&2	WALVOIL TIPO/TYPER C (SD11)
76410	RITENUTA POS.1e2/DEDUCTION POS.1&2	BASIC TIPO/TYPER I (1/2")
76097	RITENUTA POS.2/DEDUCTION POS.2	WALVOIL TIPO/TYPER F (SD4)
05851	RITENUTA POS.2/DEDUCTION POS.2	WALVOIL TIPO/TYPER G (SD5)
62178	RITENUTA POS.2/DEDUCTION POS.2	BASIC TIPO/TYPER H (3/8")

BOBINA PER DISTRIBUTORI ELETTRICI "WALVOIL SD5"

BOBINE POUR COMMANDES ELECTRIQUES
 ELECTRIC DRIVE COIL
 SPULE FUER ELEKTRISCHE STEUERUNGEN
 BOBINA DE MANDOS ELECTRICOS



Art./Ref.	Note/Notes
84537	10,5VDC
84538	24VDC

CURSORI PER DISTRIBUTORE

TIROIRS POUR DISTRIBUTEURS
 DISTRIBUTORS SPOOLS
 SCHIEBER FÜR STEUERGERÄT
 CURSORES PARA DISTRIBUIDORES



Art./Ref.	Tipo/Type	Schema Circuito/Schema Circuito	Note/Note
76098	SPOLA DE /SPOOL DE		WALVOIL TIPO/TYPE F (SD4)
76001	SPOLA DE x MOTORI ORBITALI /SPOOL DE FOR ORBITROL MOTORS		WALVOIL TIPO/TYPE F (SD4)
05855	SPOLA DE /SPOOL DE		WALVOIL TIPO/TYPE G (SD5)
17488	SPOLA DE x MOTORI ORBITALI /SPOOL DE FOR ORBITROL MOTORS		WALVOIL TIPO/TYPE G (SD5)
84750	SPOLA DE /SPOOL DE		BASIC 1°L TIPO/TYPE H (3/8")
63528	SPOLA DE /SPOOL DE		BASIC TIPO/TYPE H (3/8")
05864	SPOLA DE /SPOOL DE		WALVOIL TIPO/TYPE C (SD11)
76412	SPOLA DE /SPOOL DE		BASIC TIPO/TYPE I (1/2")
76099	SPOLA SE /SPOOL SE		WALVOIL TIPO/TYPE F (SD4)
05853	SPOLA SE /SPOOL SE		WALVOIL TIPO/TYPE G (SD5)
84751	SPOLA SE /SPOOL SE		BASIC 1°L TIPO/TYPE H (3/8")
63529	SPOLA DE /SPOOL DE		BASIC TIPO/TYPE H (3/8")
05867	SPOLA SE /SPOOL SE		WALVOIL TIPO/TYPE C (SD11)
76411	SPOLA SE /SPOOL SE		BASIC TIPO/TYPE I (1/2")

CUFFIA PORTALEVA PER DISTRIBUTORE
BOITE PORTE LEVIER
LEVER PIVOT BOX
ALU-DECKEL HEBELSEITIG
CARCASA PORTAPALANCA

Art./Ref.	Tipo/Type	Filettatura esterna/External Thread	Note/Note
05871	WALVOIL SD4/SD5 (3/8")	M8	INTERASSE FORI 35
05870	WALVOIL SD11 (1/2")	M10	INTERASSE FORI 42
62175	BASIC (3/8")	M8	INTERASSE FORI 35
76415	BASIC (1/2")	M10	INTERASSE FORI 42
05868	DINOIL MD (3/8")	M10	INTERASSE FORI 37
05869	DINOIL ML (3/8")	M10	INTERASSE FORI 37

SOFFIETTO DI PROTEZIONE PER LEVE (DISTR. DIN-OIL)
SOUFFLET DE PROTECTION POUR LEVIER (DISTR. DIN-OIL)
PROTECTION BLOWER FOR LEVERS (DIN-OIL DISTRIBUTORS)
SCHUTZBALG FUER HEBELN (STEUERGERAETE DIN-OIL)
FUELLE DE PROTECCIÓN PARA PALANCAS

Art./Ref.
19441

CUFFIA PORTAPOSIZIONATORE STANDARD
BOITE PORTE POSITIONNEUR STANDARD
STANDARD END CAP
ALU-DECKEL
CARCASA PORTA POSICIONES STANDARD

Art./Ref.	Tipo/Type
05879	WALVOIL SD4/SD5 (3/8")
05878	WALVOIL SD11 (1/2")
62176	BASIC (3/8")
76414	BASIC (1/2")
05877	DINOIL MD/ML (3/8")

LEVE PER DISTRIBUTORI

LEVIER POUR DISTRIBUTEUR
 DISTRIBUTOR HANDLEVERS
 HEBEL FÜR STEUERGERÄTE
 PALANCA PARA DISTRIBUIDORES



Art./Ref.	Tipo/Type	Filettatura esterna/External Thread	Lunghezza mm/Lenght mm	Brand	Applicazione/Application
05872	F&G	M8	120	WALVOIL	TIPO/TYPE F&G (SD4/SD5)
05880	-	M8	200	-	-
05873	-	M8	300	-	-
05874	A&B&C	M10	200	DINOIL - WALVOIL	TIPO A, TIPO/TYPE B (ML), TIPO A, TIPO/TYPE C (SD11)
05875	A&B&C	M10	350	DINOIL - WALVOIL	TIPO A, TIPO/TYPE B (ML), TIPO A, TIPO/TYPE C (SD11)
05876	CLOCHE	M12	200	DINOIL - WALVOIL	CLOCHE, CLOCHE

DEVIATORI DI FINE CORSA PER RIMORCHI CON PRESA DI FORZA IDRAULICA

VALVE D'ARRÊT POUR REMORQUES AVEC PRISE DE FORCE HYDRAULIQUE
 STOP VALVE FOR TRAILERS WITH HYDRAULIC P.T.O.
 ENDLAUFVENTIL FÜR ANHÄNGER MIT HYDRAULISCHER ZAPFWELLE
 DESUIDOR DE FINAL DE CARRERA PARA RAMOLQUES CON TOMA DE FUERZA HIDRAULICA

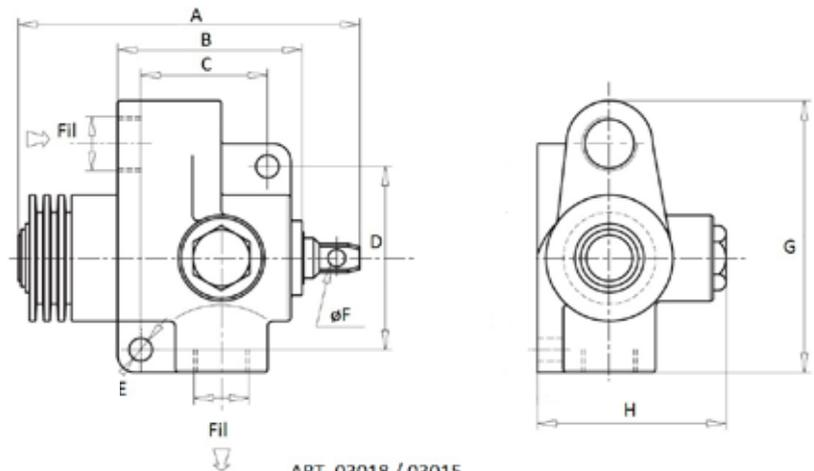

ART. 03018 / 03015

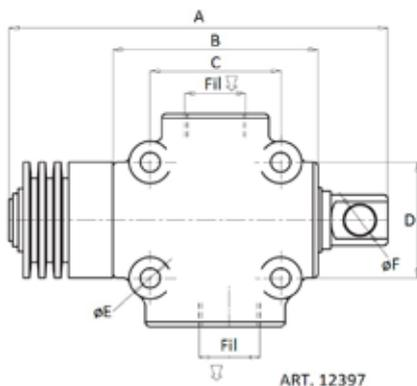

ART. 12397

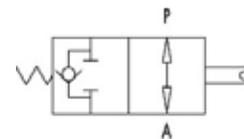

Art./Ref.	Capacità LT/ Capacity LT	Pressione max (bar)/ Pression max (bar)	Filettatura interna/ Inner Thread	A mm	B mm	C mm	D mm	E mm	F mm	G mm	H mm	Note/Note
03018	60	350	3/8"	130	69	45	66	8,5	6,5	103	68	NORMALMENTE APERTO NORMALLY OPENED
03015	80	350	1/2"	130	69	45	66	8,5	6,5	103	68	NORMALMENTE APERTO NORMALLY OPENED
12397	120	350	3/4"	173	88	56	50	8,5	13	92	50	NORMALMENTE APERTO NORMALLY OPENED

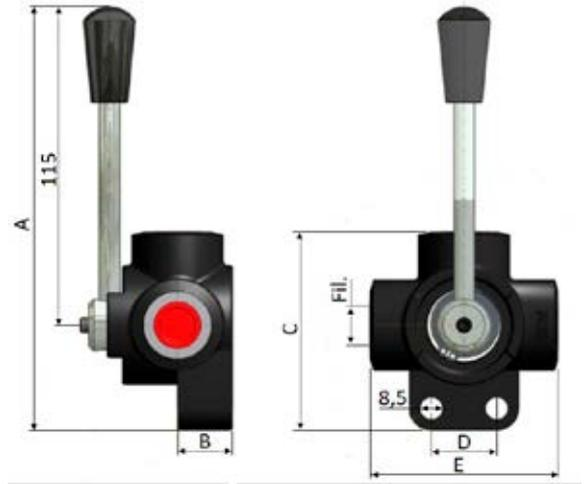
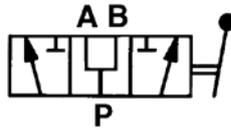
DEVIATORI DI FLUSSO A 3 VIE
ROBINETS A TROIS VOIES: A COMANDE MANUELLE
3 WAYS FLOW DIVIDERS
3-WEGE-HÄHNNE: HANDBETÄTIGUNG, DAUERDURCHFLUSS: SPEISST ZWEI VERSCHIEDEN LEITUNGEN.
DESVIADOR A 3 VIAS

Art./Ref.	Pressione max (bar)/ Pression max (bar)	Capacità LT/ Capacity LT	Filettatura interna/ Inner Thread	A mm	B mm	C mm	D mm	E mm
01056	350	60	3/8"	155,5	21	75,5	25	70
01094	350	90	1/2"	161	24	86	32	80
01096	350	120	3/4"	168,5	26	98,5	32	90

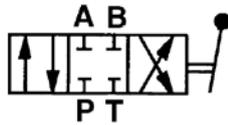
DEVIATORI DI FLUSSO A 4 VIE
ROBINETS A QUATRE VOIES: A COMANDE MANUELLE
4 WAYS FLOW DIVIDERS
4 WEGE-HÄHNNE: ERMOGLICHEN DIE STROMUMKEHRUNG MIT DERSELBEN NÜTZUNG
DESVIADOR A 4 VIAS

Art./Ref.	Pressione max (bar)/ Pression max (bar)	Capacità LT/ Capacity LT	Filettatura interna/ Inner Thread	A mm	B mm	C mm	D mm	E mm
01042	350	60	3/8"	155	24	80	54	80
01043	350	90	1/2"	155	24	80	54	80

DEVIATORI DI FLUSSO A 6 VIE
ROBINETS A SIX VOIES: A COMANDE MANUELLE
6 WAYS FLOW DIVIDERS
6 WEGE HÄHNNE - DAUERDURCHFLUSS: SPEISST 2 LEITUNGEN BEIM ANSAUGEN UND BEI DRUCK.
DESVIADOR A 6 VIAS

Art./Ref.	Pressione max (bar)/ Pression max (bar)	Capacità LT/ Capacity LT	Filettatura interna/ Inner Thread	A mm	B mm	C mm	D mm	E mm
04819	350	60+60	3/8"	155,5	21	75,5	25	70
03941	350	90+90	1/2"	161	24	86	32	80

DEVIATORI A 3 VIE A COMANDO ELETTRICI

DIVISEUR A 3 VOIES A COMMANDE ELECTRIQUE
FLOW SELECTOR 3 WAYS ELECTRIC CONTROL
UMSCHALVENTIL 3-WEG
DEVIDOR DE 3 VIAS CON COMANDO ELETRICO

Rexroth
 Bosch Group

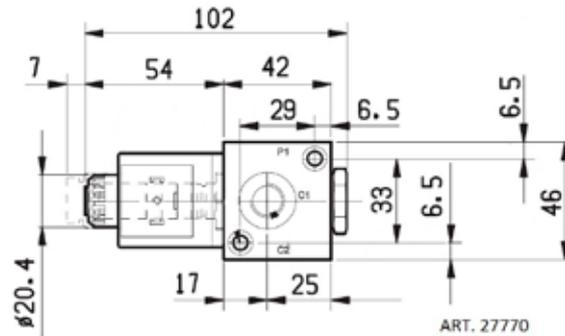

ART. 27770

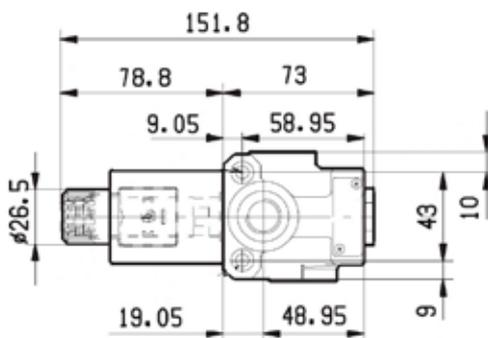

ART. 27771

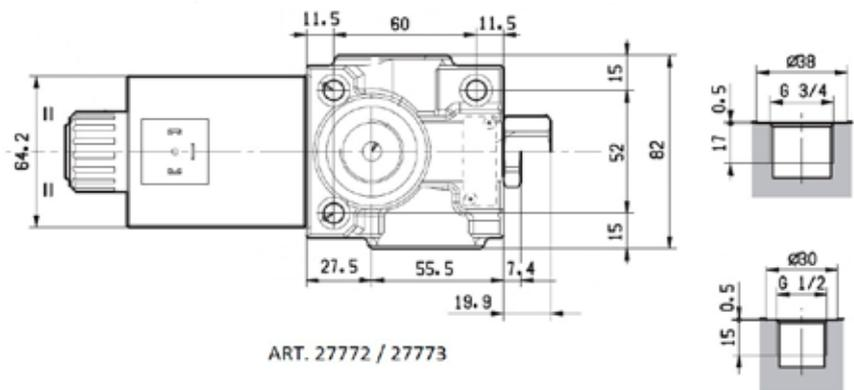

ART. 27772 / 27773

Art./Ref.	Pressione max (bar)/ Pression max (bar)	Capacità LT/ Capacity LT	Filettatura interna/ Inner Thread	Volt/Volt	Schema Circuito/Schema Circuito	Note/Notes
27770	250	20	1/4"	12VDC		26 Watt - 2,15 Ampere/26 Watt - 2,15 Ampere/26 Watt - 2,15 Ampere/26 Watt - 2,15 Ampere
27771	250	60	3/8"	12VDC		36 Watt - 3 Ampere/36 Watt - 3 Ampere/36 Watt - 3 Ampere/36 Watt - 3 Ampere
27772	250	120	1/2"	12VDC		44 Watt - 3,6 Ampere/44 Watt - 3,6 Ampere/44 Watt - 3,6 Ampere/44 Watt - 3,6 Ampere
27773	250	120	3/4"	12VDC		44 Watt - 3,6 Ampere/44 Watt - 3,6 Ampere/44 Watt - 3,6 Ampere/44 Watt - 3,6 Ampere

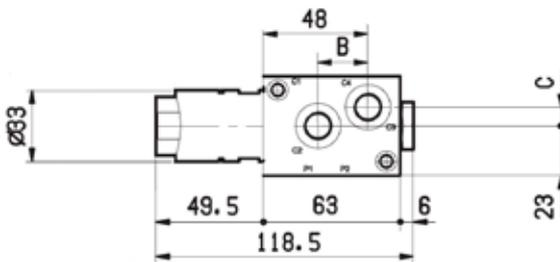
DEVIATORI A 6 VIE A COMANDO ELETTRICI
DIVISEUR A 6 VOIES A COMMANDE ELECTRIQUE
FLOW SELECTOR 6 WAYS ELECTRIC CONTROL
UMSCHALVENTIL 6 WEG
DEVIDOR DE 6 VIAS CON COMANDO ELETRICO

ART. 27774

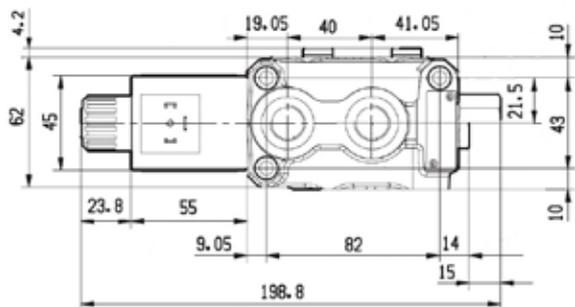

ART. 27775

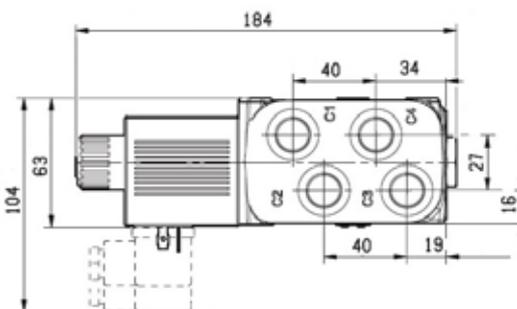

ART. 27776

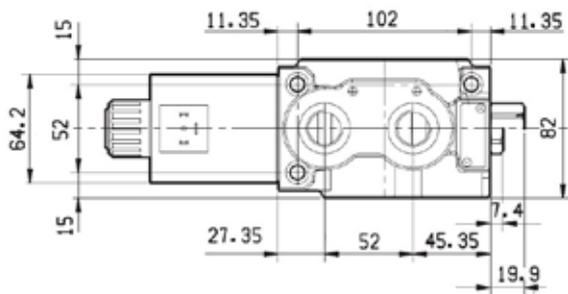

ART. 27777 / 27778

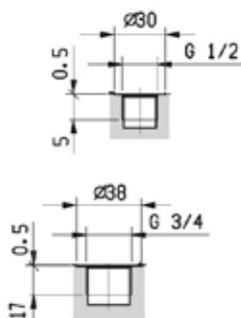

Art./Ref.	Pressione max (bar)/ Pression max (bar)	Capacità LT/ Capacity LT	Filettatura interna/ Inner Thread	Volt/Volt	Schema Circuito/ Schema Circuito	Note/Notes
27774	250	25	1/4"	12VDC		26 Watt - 2,15 Ampere/26 Watt - 2,15 Ampere/26 Watt - 2,15 Ampere/26 Watt - 2,15 Ampere/26 Watt - 2,15 Ampere/26 Watt - 2,15 Ampere
27775	250	60	3/8"	12VDC		36 Watt - 3 Ampere/36 Watt - 3 Ampere/36 Watt - 3 Ampere/36 Watt - 3 Ampere/36 Watt - 3 Ampere/36 Watt - 3 Ampere
27776	250	60	3/8"	12VDC		36 Watt - 3 Ampere/36 Watt - 3 Ampere/36 Watt - 3 Ampere/36 Watt - 3 Ampere/36 Watt - 3 Ampere
27777	250	120	1/2"	12VDC		44 Watt - 3,6 Ampere/44 Watt - 3,6 Ampere/44 Watt - 3,6 Ampere/44 Watt - 3,6 Ampere/44 Watt - 3,6 Ampere
27778	250	120	3/4"	12VDC		44 Watt - 3,6 Ampere/44 Watt - 3,6 Ampere/44 Watt - 3,6 Ampere/44 Watt - 3,6 Ampere/44 Watt - 3,6 Ampere

DEVIATORI ELETTRICI MODULARI DA 1/4"

DEVIATEURS ELECTRIQUES MODULAR
ELECTRIC MODULAR FLOW SELECTOR
EL ABLEN KER
DEVIADORES ELECTRICOS MODLARES

Rexroth
Bosch Group

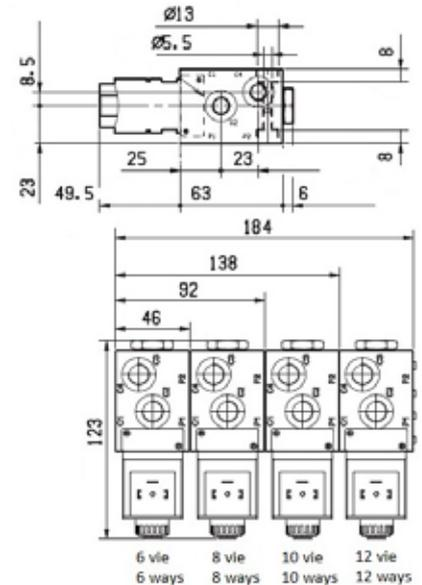
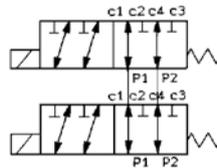

Art./Ref.	Pressione max (bar)/ Pression max (bar)	Capacità LT/ Capacity LT	Filettatura interna/ Inner Thread	Tipo/Type	Volt/Volt	Note/Note
27779	250	20	1/4"	6 VIE / WAYS	12VDC	26 Watt - 2,15 Ampere
27780	250	20	1/4"	8 VIE / WAYS	12VDC	26 Watt - 2,15 Ampere
27781	250	20	1/4"	10 VIE / WAYS	12VDC	26 Watt - 2,15 Ampere
27782	250	20	1/4"	12 VIE / WAYS	12VDC	26 Watt - 2,15 Ampere

DEVIATORI ELETTRICI MODULARI DA 3/8"

DEVIATEURS ELECTRIQUES MODULAR
ELECTRIC MODULAR FLOW SELECTOR
EL ABLEN KER
DEVIADORES ELECTRICOS MODLARES

Rexroth
Bosch Group

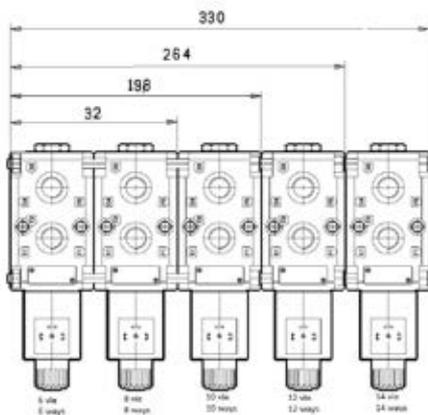
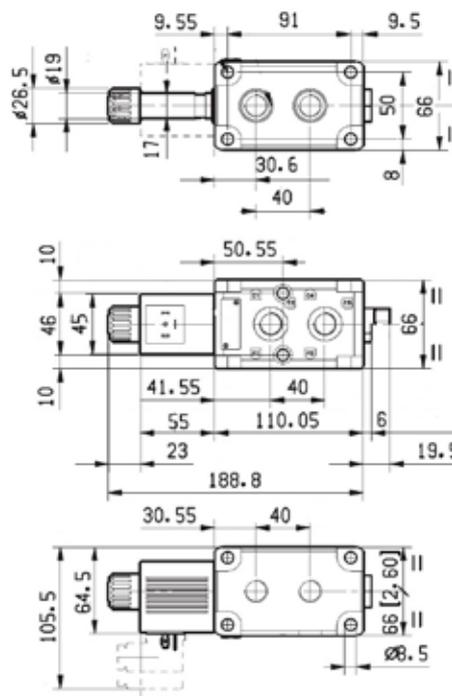
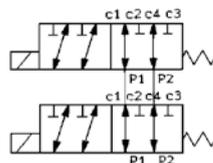

Art./Ref.	Pressione max (bar)/ Pression max (bar)	Capacità LT/ Capacity LT	Filettatura interna/ Inner Thread	Tipo/Type	Volt/Volt	Note/Note
27783	250	50	3/8"	6 VIE / WAYS	12VDC	36 Watt - 3 Ampere
34227	250	50	3/8"	6 VIE / WAYS	24VDC	36 Watt - 1,53 Ampere
27784	250	50	3/8"	8 VIE / WAYS	12VDC	36 Watt - 3 Ampere
27785	250	50	3/8"	10 VIE / WAYS	12VDC	36 Watt - 3 Ampere
27786	250	50	3/8"	12 VIE / WAYS	12VDC	36 Watt - 3 Ampere
27787	250	50	3/8"	14 VIE / WAYS	12VDC	36 Watt - 3 Ampere

DEVIATORI ELETTRICI MODULARI DA 1/2"

DEVIATEURS ELECTRIQUES MODULAR
ELECTRIC MODULAR FLOW SELECTOR
EL ABLEN KER
DEVIADORES ELECTRICOS MODLARES

Rexroth
Bosch Group

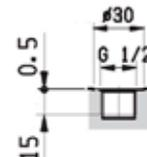
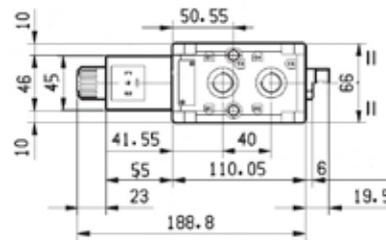
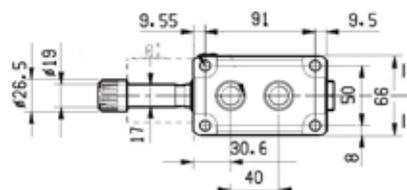
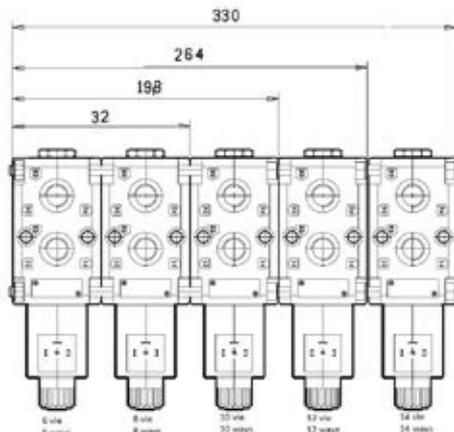
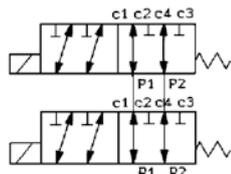

Art./Ref.	Pressione max (bar)/ Pression max (bar)	Capacità LT/ Capacity LT	Filettatura interna/ Inner Thread	Tipo/Type	Volt/Volt	Note/Note
27788	250	90	1/2"	6 VIE / WAYS	12VDC	44 Watt - 3,6 Ampere
34228	250	90	1/2"	6 VIE / WAYS	24VDC	44 Watt - 1,8 Ampere
27789	250	90	1/2"	8 VIE / WAYS	12VDC	44 Watt - 3,6 Ampere

ELETTRIVALVOLE CETOP 3 12VDC

CONTROLE DIRECTION CETOP 3
ELECTRIC VALVES CETOP 3
ELECTROVENTILEN CETOP 3
ELECTROVÁLVULA CETOP 3

Art./Ref.	Pressione max (bar)/ Pression max (bar)	Capacità LT/ Capacity LT	Volt/Volt	Note/Note	Immagine/Image
17061	250	50	12VDC	N° 2 BOBINE / COIL	
17062	250	50	12VDC	N° 2 BOBINE / COIL	
17063	250	50	12VDC	N° 2 BOBINE / COIL	
17064	250	50	12VDC	N° 2 BOBINE / COIL	
17065	250	50	12VDC	N° 1 Bobine	
17066	250	50	12VDC	N° 1 BOBINE / COIL	

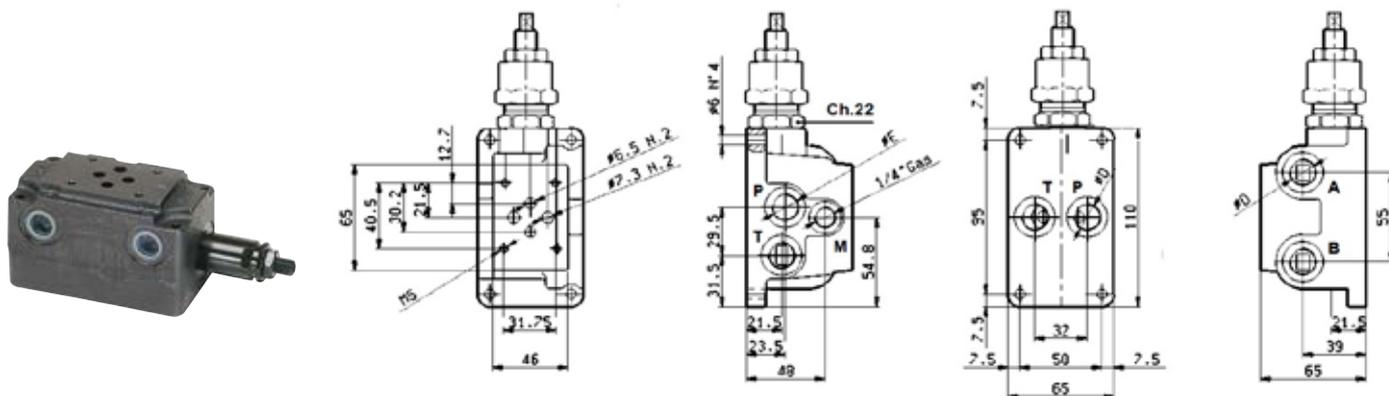

BASE SINGOLA PER ELETTROVALVOLA CETOP 3
BASE SINGLE
SINGLE STATION SUBPLATES WITH RELIEF VALVE
EINZELNAN SCHLUSSPLATTE MIT DRUCKBEGRENZUNGSVENTIL
BASE SIMPLE PARA ELECTROVÁLVULA CETOP 3

Art./Ref.	Filettatura interna/Inner Thread
17071	3/8"

ROTATORE DA 3,5 T
PIVOTANT POUR PINCE 3,5 TON
3,5 T SWIVELLING JOINT
3,5 T DREH MOTOR
ROTATOR 3,5 T

Note:

ROTAZIONE: 360°

PRESSIONE MAX: 250 bar

PORTATA: 20 LT/MIN.

PESO: 17 KG

Notes:

ROTATION: 360°

MAX PRESSURE: 250 bar

FLOW RATE: 20 LT/MIN.

WEIGHT: 17 KG

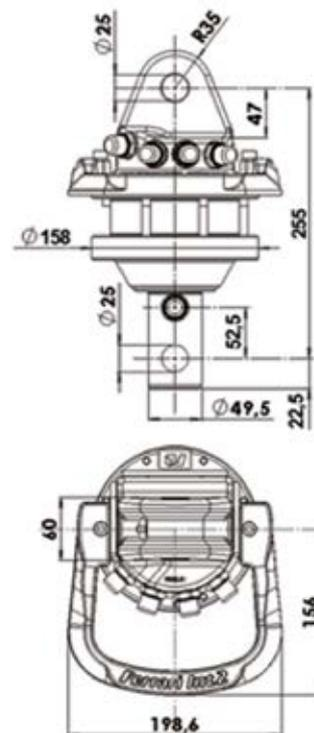

Art./Ref.	Capacità LT/ Capacity LT	Pressione max (bar)/ Pression max (bar)	Note/Notes
16816	20	250	Carico Statico / Static Load 3500 Kg. Carico Dinamico / Dinamic Load 1750 Kg. Peso / Weight 17 Kg/

ROTATORE DA 5 T

PIVOTANT POUR PINCE 5 TON
 5 T SWIVELLING JOINT
 5 T DREH MOTOR
 ROTATOR 5 T

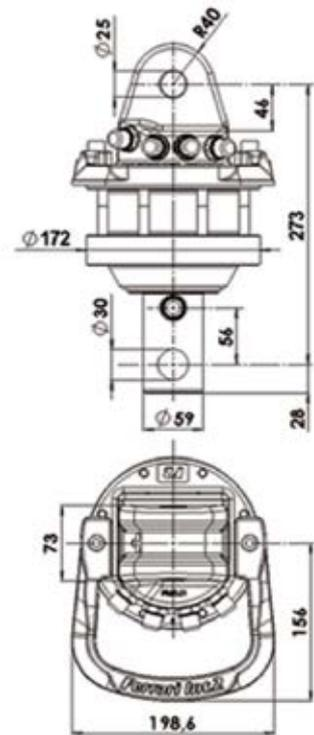

Note:
 ROTAZIONE: 360°
 PRESSIONE MAX: 250 bar
 PORTATA: 20 LT/MIN.
 PESO: 25 KG

Notes:
 ROTATION: 360°
 MAX PRESSURE: 250 bar
 FLOW RATE: 20 LT/MIN.
 WEIGHT: 25 KG

Art./Ref.	Capacità LT/Capacity LT	Pressione max (bar)/ Pression max (bar)	Note/Notes
16817	20	250	Carico Statico / Static Load 5000 Kg. Carico Dinamico / Dinamic Load 2500 Kg. Peso / Weight 25 Kg

ROTATORE DA 7,5 T

PIVOTANT POUR PINCE 7,5 TON
 7,5 T SWIVELLING JOINT
 7,5 T DREH MOTOR
 ROTATOR 7,5 T

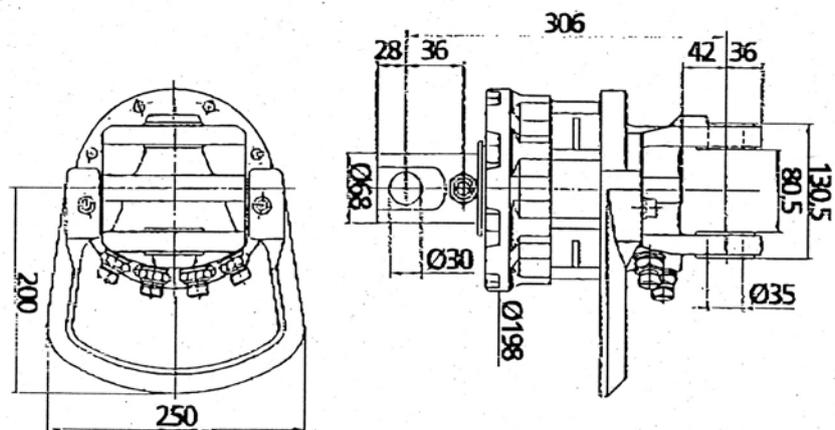

Note:
 ROTAZIONE: 360°
 PRESSIONE MAX: 250 bar
 PORTATA: 25 LT/MIN.
 PESO: 36 KG

Notes:
 ROTATION: 360°
 MAX PRESSURE: 250 bar
 FLOW RATE: 25 LT/MIN.
 WEIGHT: 36 KG

Art./Ref.	Capacità LT/Capacity LT	Pressione max (bar)/ Pression max (bar)	Note/Notes
16818	25	250	Carico Statico / Static Load 7000 Kg. Carico Dinamico / Dinamic Load 3500 Kg. Peso / Weight 36Kg

ROTATORE CON FLANGIA DA 3,5 T

ROTATEUR AVEC FLASQUE
 ROTATOR WITH RH FLANGE
 DREHMOTOR MIT FLANSCH
 ROTATOR CON BRIDA

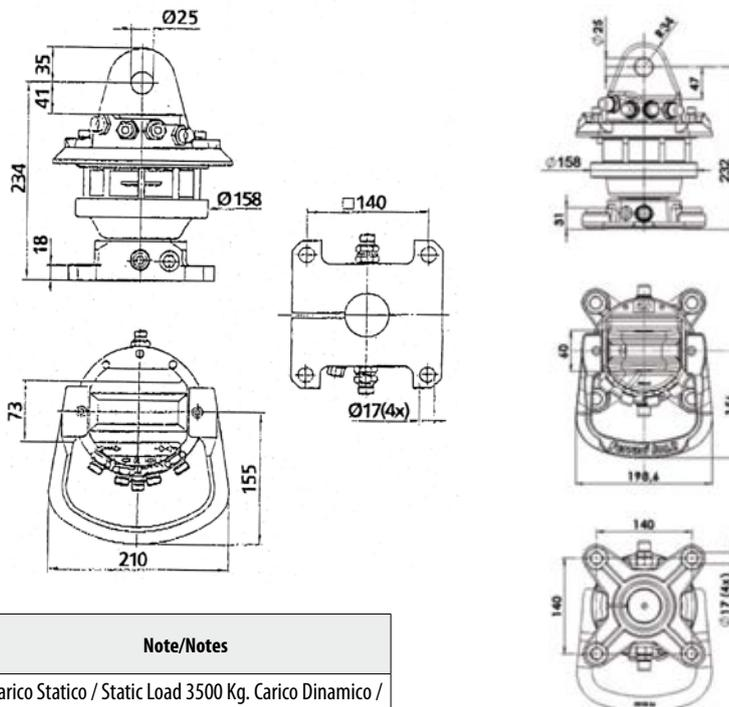

Note:
 ROTAZIONE: 360°
 PRESSIONE MAX: 250 bar
 PORTATA: 20 LT/MIN.
 PESO: 22 KG

Notes:
 ROTATION: 360°
 MAX PRESSURE: 250 bar
 FLOW RATE: 20 LT/MIN.
 WEIGHT: 22 KG

Art./Ref.	Capacità LT/ Capacity LT	Pressione max (bar)/ Pression max (bar)	Note/Notes
31766	20	250	Carico Statico / Static Load 3500 Kg. Carico Dinamico / Dinamic Load 1750 Kg. Peso / Weight 22 Kg

ROTATORE CON FLANGIA DA 5 T

ROTATEUR AVEC FLASQUE
 ROTATOR WITH RH FLANGE
 DREHMOTOR MIT FLANSCH
 ROTATOR CON BRIDA

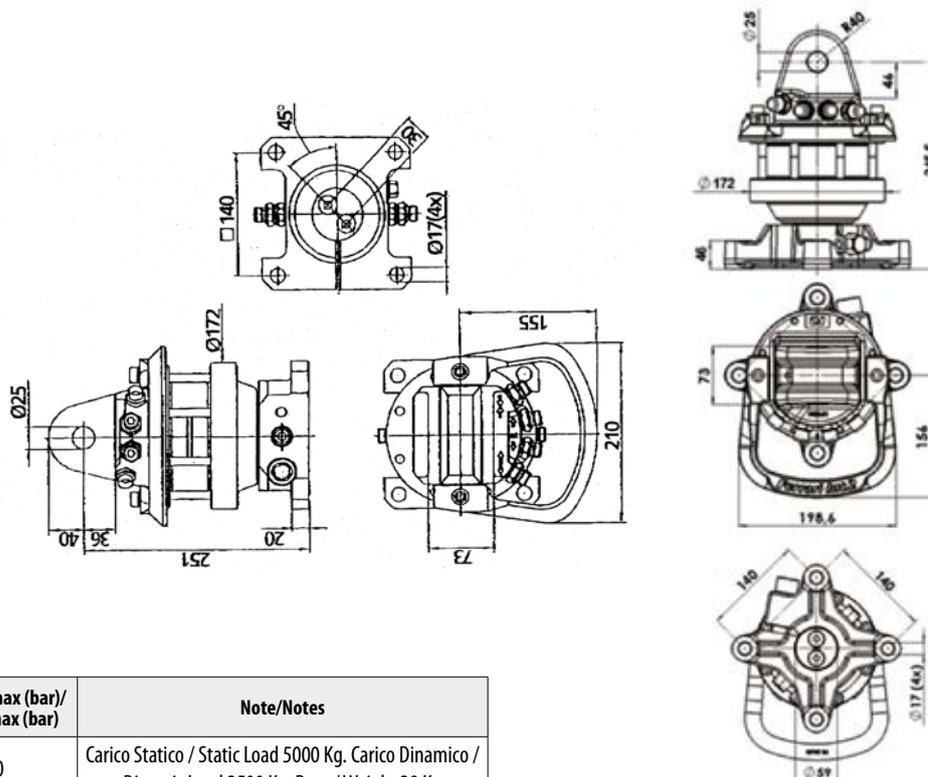

Note:
 ROTAZIONE: 360°
 PRESSIONE MAX: 250 bar
 PORTATA: 20 LT/MIN.
 PESO: 28 KG

Notes:
 ROTATION: 360°
 MAX PRESSURE: 250 bar
 FLOW RATE: 20 LT/MIN.
 WEIGHT: 28 KG

Art./Ref.	Capacità LT/ Capacity LT	Pressione max (bar)/ Pression max (bar)	Note/Notes
31767	20	250	Carico Statico / Static Load 5000 Kg. Carico Dinamico / Dinamic Load 2500 Kg. Peso / Weight 28 Kg

VALVOLE DI MASSIMA PRESSIONE DIRETTA

LIMITEUR DE PRESSION DIRECTE

MAX. PRESSURE VALVE

ÜBERDRUCKVENTIL

VALVULAS LIMITADORA DE PRESIÓN

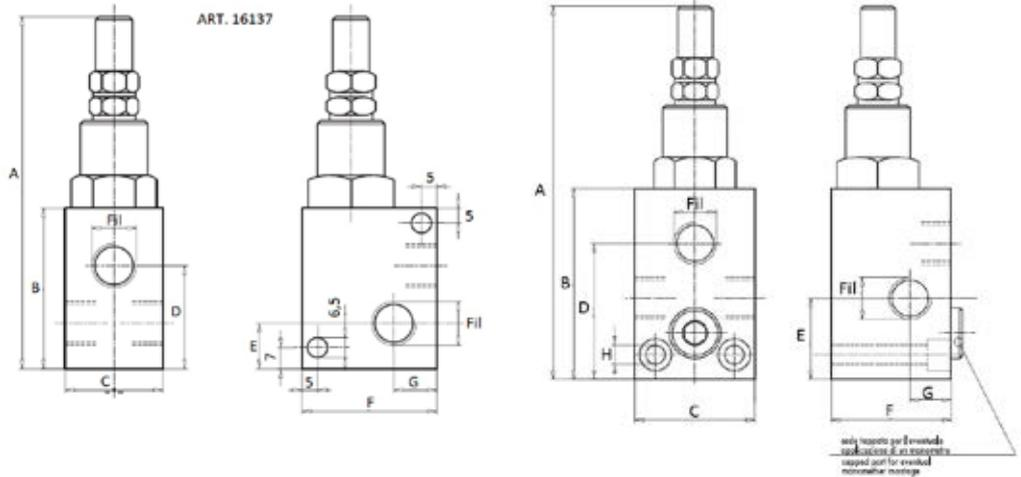
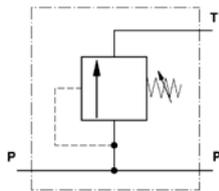

Art./Ref.	Pressione max (bar)/ Pression max (bar)	Capacità LT/ Capacity LT	Filettatura interna/ Inner Thread	A mm	B mm	C mm	D mm	E mm	F mm	G mm	H mm	Note/Note
16137	180	30	1/4"	114	52	30	34	13	40	12		GRANO / SCREW
04203	180	45	3/8"	134	72	40	49,5	26	40	15	6,5	GRANO
12568	180	45	3/8"	134	72	40	49,5	26	40	15	6,5	VOLANTINO / MALE KNOB
04204	180	70	1/2"	139	77	45	54	29,5	45	17,5	6,5	GRANO
12569	180	70	1/2"	139	77	45	54	29,5	45	17,5	6,5	VOLANTINO / MALE KNOB
31783	180	90	3/4"	154	92	50	68	35	50	17,5	8,5	GRANO / SCREW

VALVOLA DI MASSIMA PRESSIONE INCROCIATA

CLAPET PRESSION MAXIMA ENCROISEE

MAX PRESSURE VALVE WITH CROSS CONNECTION

ÜBERDRUCKVENTIL MIT ABWECHSELNEN DRUCK-FLUSS

VALVULA DE MAX PRESSION CRUZADA

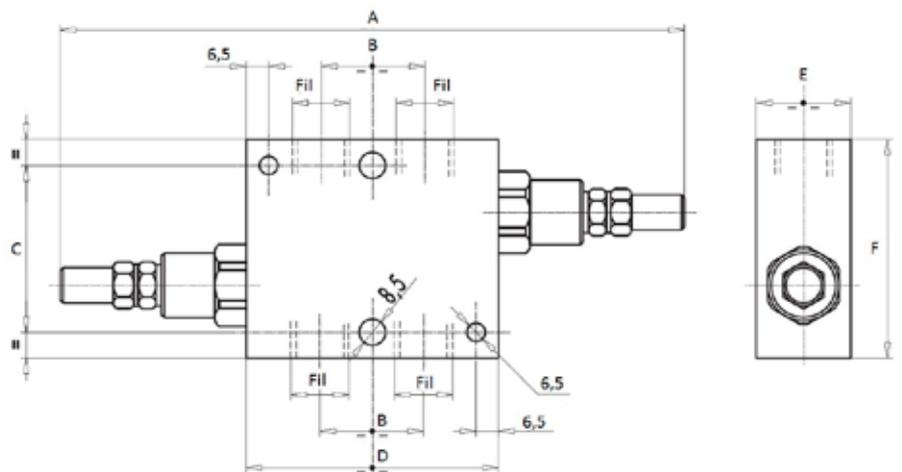

Valvole incrociate:

sono valvole di massima pressione con scarico incrociato proteggono il cilindro da aumenti di pressione che derivano dal funzionamento intermittente del cilindro stesso.

Notes: Max pressure valve whit cross connection:

Maximum pressure cross connection valves used to the cylinder

from sudden increase of pressure caused by the cylinder intermittent working.

Art./Ref.	Pressione max (bar)/ Pression max (bar)	Capacità LT/ Capacity LT	Filettatura interna/ Inner Thread	A mm	B mm	C mm	D mm	E mm	F mm
16753	180	45	3/8"	176	33	54	80	30	70
16086	180	70	1/2"	200	38	54	80	30	70

VALVOLE ANTIURTO PER MOTORI ORBITALI OMP/OMR

CLAPET ANTI-CHOC POUR MOTEUR ORBITAL SERIE OMP/OMR
 STABILIZING ANTISHIP VALVE HYDRAULIC MOTORS
 DRUCKAUSGLEICHVENTIL VENTILMOTOREN
 VALVULA ANTISALTOS MOTOR IDRAULICO

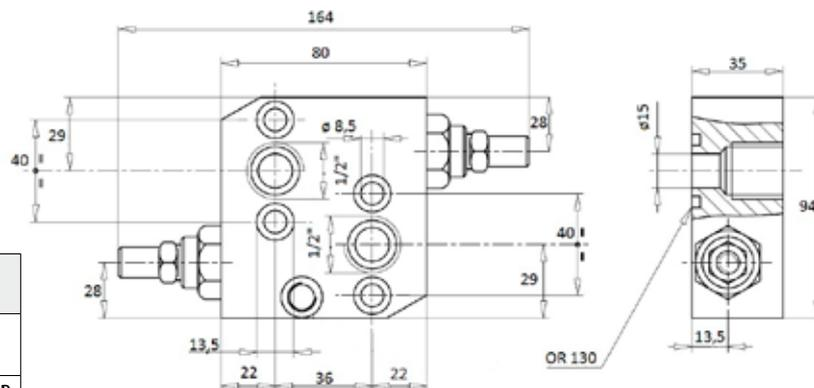

Art./Ref.	Pressione max (bar)/ Pression max (bar)	Capacità LT/ Capacity LT	Note/Note
12543	180	60	MOTORI OMP-OMR / OMP-OMR MOTOR
91128	180	60	MOTORI KS / KS MOTOR

VALVOLA UNIDIREZIONALE TENUTA A CONO (VALVOLA DI NON RITORNO)

CLAPET ANTI RETOUR, UNIDIRECTIONNEL
 ONE WAY VALVE
 RÜCKSCHLAGVENTIL
 VALVULA ANTIRETORNO

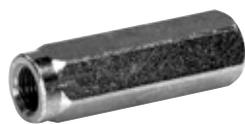

Funzionamento: Consentono il flusso in una direzione (quella della freccia) mentre lo impediscono in quella opposta.

Functioning: They allow the free flow in one direction (as stated by the arrow) while the opposite direction is not permitted.

Art./Ref.	Pressione max (bar)/ Pression max (bar)	Capacità LT/ Capacity LT	Filettatura interna/ Inner Thread	A mm	C mm	D mm	Note/Note
04205	350	20	1/4"	62	19	21	-
04206	350	45	3/8"	68	24	26,5	-
04207	350	70	1/2"	77	30	34	-
17635	350	110	3/4"	88	36	40	N°1 FORO/HOLE Ø 1

VALVOLA UNIDIREZIONALE CON TENUTA A CONO (VALVOLA DI NON RITORNO)

CLAPET UNIDIRECTIONNEL ETANCHEITE'CONIQUE
 ONE WAY CONICAL VALVE
 RÜCKSCHLAGVENTIL MIT KONISCHER DICHTIGKEIT
 VALVULA ANTIRETORNO CÓNICA

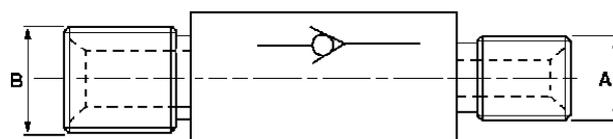

Art./Ref.	Pressione max (bar)/ Pression max (bar)	Capacità LT/ Capacity LT	Filettatura esterna/ External Thread	Filettatura interna/ Inner Thread
04208	300	30	3/8"	1/2"

VALVOLE DI BLOCCO PILOTATE DOPPIO EFFETTO IN LINEA

CLAPET DE BLOCAGE DOUBLE EFFET PILOTEE EN LIGNE

CHECK VALVES

RÜCKSCHLAGVENTIL

VALVULA ANTIRATORNO DOBLE PILOTADA EN LINEA

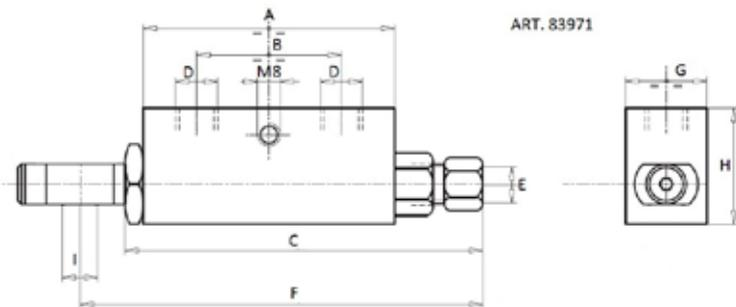
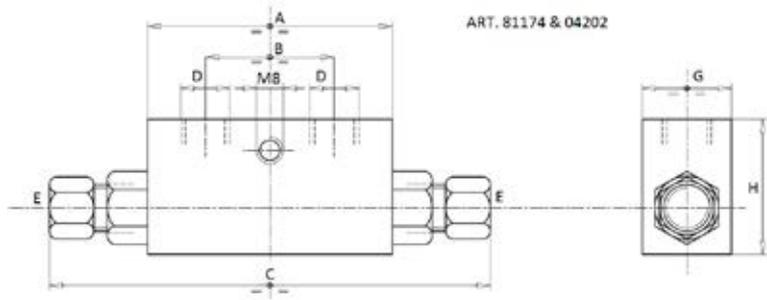
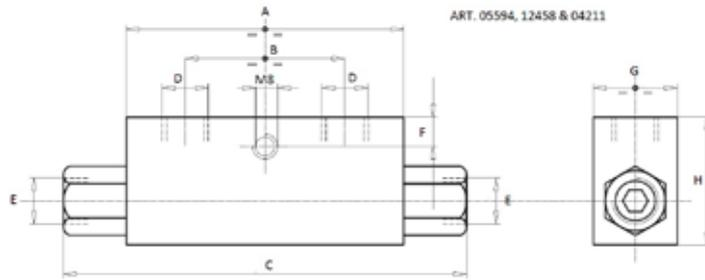

Art./Ref.	Pressione max (bar)/ Pression max (bar)	Capacità LT/ Capacity LT	A mm	B mm	C mm	D mm	E mm	F mm	G mm	H mm	Note/Note
05594	350	20	64	36	113	1/4"	1/4"	8	30	40	
81174	350	20	64	36	130	1/4"	12L		30	40	
12458	350	35	80	38	128	3/8"	3/8"	8	30	40	
04202	350	30	64	36	130	3/8"	12L		30	40	
83971	350	30	64	36	106	3/8"	12L - 3/8"	136	30	40	UN OCCHIO PREMONTATO / ONE BANJIO PREASSEMBLED
04211	350	50	90	45	142	1/2"	1/2"	12,5	35	45	

VITE STROZZATRICE

VIS 1/4

THROTTLE SCREW

DROSSELSCHRAUBE

TORNILLO ESTRANGULADOR

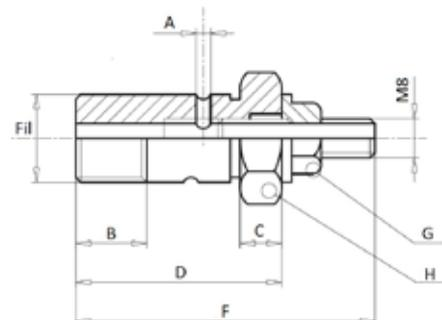

Art./Ref.	Filettatura esterna/ External Thread	A mm	C mm	B mm	D mm	F mm	G mm	H mm
81193	1/4"	2,5	7	15	36	53	13	19
81194	3/8"	3	8	15	39	58	13	22

VALVOLA DI BLOCCO E CONTROLLO DISCESA

CLAPET OVERCENTER
OVERCENTER VALVE
SENKBREMSVENTIL
OVERCENTER VÁLVULA

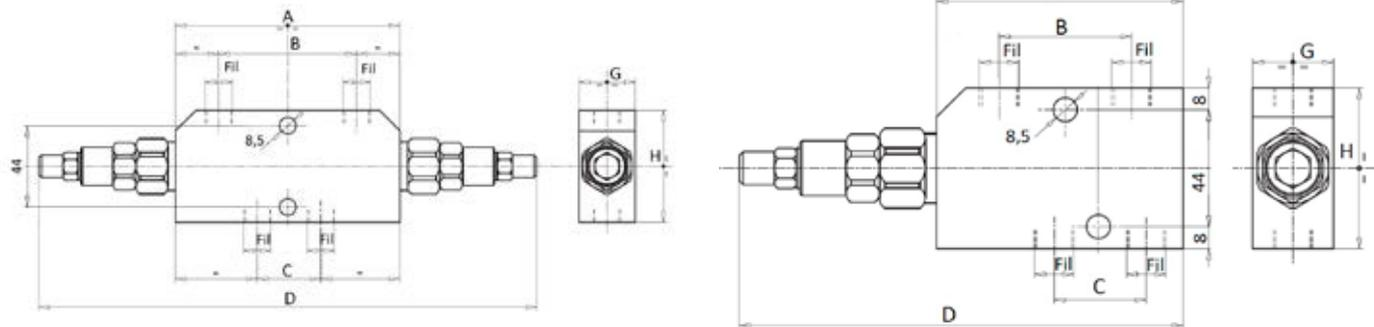

Art./Ref.	Capacità LT/ Capacity LT	Pressione max (bar)/ Pression max (bar)	Filettatura esterna/ External Thread	Tipo/Type	A mm	B mm	C mm	D mm	G mm	H mm	Note/Note
31778	35	350	3/8"	SEMPLICE EFFETTO / SINGLE ACTING	90	48	32	162	30	60	PILOTAGGIO / PILOT RATIO 1:3,1
31779	50	350	1/2"	SEMPLICE EFFETTO / SINGLE ACTING	90	48	35	162	30	60	PILOTAGGIO / PILOT RATIO 1:3,1
31780	35	350	3/8"	DOPPIO EFFETTO / DOUBLE ACTING	120	73	34	264	30	60	PILOTAGGIO / PILOT RATIO 1:3,1
31781	50	350	1/2"	DOPPIO EFFETTO / DOUBLE ACTING	120	73	36	264	30	60	PILOTAGGIO / PILOT RATIO 1:3,1

VALVOLA PER RIBALTAMENTO DELL'ARATRO

CLAPET RENVERSEMENT CHARRUE
PLOUGH REVOLVING VALVE
PFLUNGWENDEVENTIL
VALVULA LEVANTAMIENTO DE ARADO

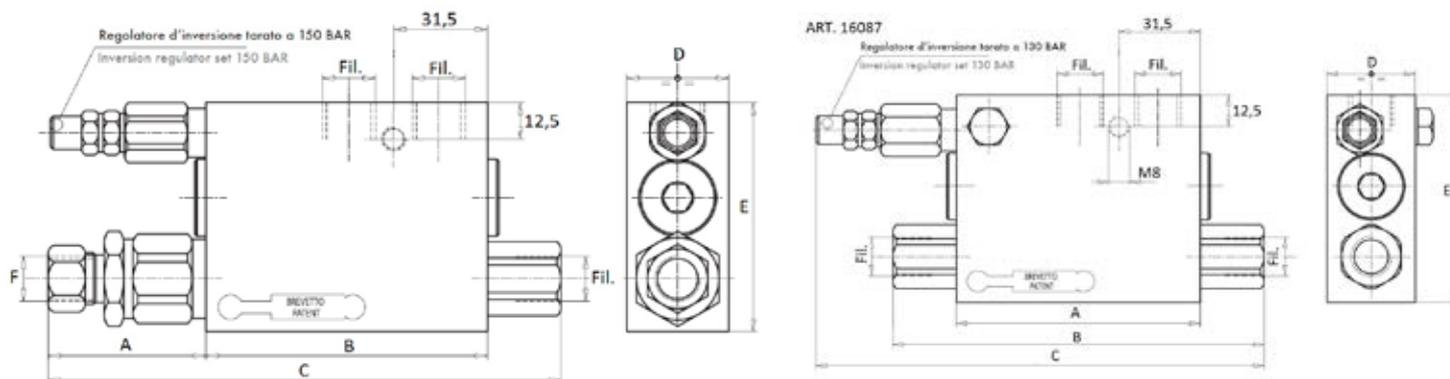

Art./Ref.	Modello/ Model	Tipo/Type	Filettatura interna/ Inner Thread	A mm	B mm	C mm	D mm	E mm	F mm	Note/Note
04659	60/80	DOPPIO EFFETTO / DOUBLE ACTING	3/8"	58	94	176	35	80	ø12	ALES. CILINDRO / CYLINDER BORE 60/80
04660	80/100	DOPPIO EFFETTO / DOUBLE ACTING	3/8"	58	94	176	35	80	ø12	ALES. CILINDRO / CYLINDER BORE 80/100
16087	60/80	SEMPLICE EFFETTO / SINGLE ACTING	3/8"	94	142	177	35	80	-	ALES. CILINDRO / CYLINDER BORE 60/80

KIT RACCORDERIA PER APPLICAZIONE VALVOLE

L'APPLICAZIONE DELLE VALVOLE

KIT DE FLEXIBLES ET RACCORDS POUR L'APPLICATION DES CLAPETS

PLOUGH VALVE SET PFLUGVENTILANBAUSATZ

KIT DE RACORERTA

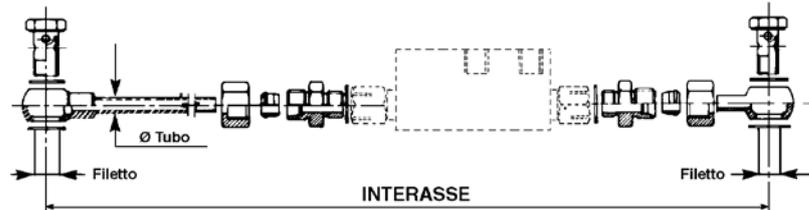

Art./Ref.	Tipo/Type	Filettatura esterna/ External Thread	Lunghezza mm/ Length mm	Note/Note
05507	Ø TUBO/TUBE 12	1/4"	700	ART. 05594
04631	Ø TUBO/TUBE 12	3/8"	700	ART.12458
04862	Ø TUBO/TUBE 15	1/2"	700	ART.04211
05508	Ø TUBO/TUBE 12	3/8"	650	ART.04202-81174

VALVOLA UNIDIREZIONALE CON BLOCCO AUTOMATICO ("PARACADUTE")

CLAPET UNIDIRECTIONNEL

AUTOMATIC CHECK VALVE

ROHRBRUCHSICHERUNGSVENTIL

VALVULA INIDIRECCIONAL CON BLOQUEO AUTOMÁTICO ("PARACAIDAS")

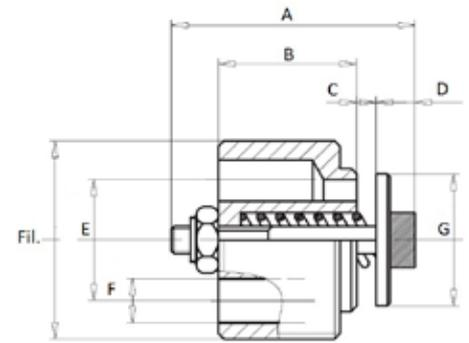
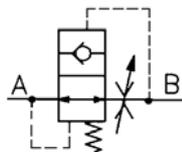

Funzionamento: Sono valvole di controllo. Vengono montate direttamente sulle connessioni dei cilindri per evitare, nel caso di rottura dei tubi, una discesa incontrollata del carico. Un disco viene tenuto sollevato da una molla, permettendo il flusso libero da A a B. In condizioni normali, il deflusso da B a A avviene regolarmente, se la portata di deflusso dovesse superare il valore di taratura della molla il disco andrà a posizionarsi sulla sede della valvola interrompendo totalmente il flusso da B a A.

Fuctioning: They are safety valves. They are mounted directly on the connection cylinders to avoid, in case of hoses brake, an uncontrolled load descent. A disk is lifted by a spring, allowing the flow from A to B. in normal conditions the spring calibration valve, the disk will positioning itself on the valve seat, breaking the flow from B to A.

Art./Ref.	Pressione max (bar)/ Pression max (bar)	Capacità LT/ Capacity LT	Filettatura esterna/ External Thread	A mm	B mm	C mm	D mm	E mm	F mm	G mm
05138	350	25	1/4"	18	8	1	5	8	2,5	9,5
05139	350	50	3/8"	23	10,5	1,2	5	10,5	3,5	12,5
05140	350	80	1/2"	29	13	1,6	5	12,5	4,5	15

COLONNETTA PER VALVOLA PARACADUTE

COLONNETTE POUR VALVE PARE-CHUTE

STUD-BOLT FOR AUTOMATIC CHECK VALVE

ROHRBRUCHSICHERUNGSBUCHSE

COLUMN PARA VALVULAS PARACAIDAS



Art./Ref.	Tipo/Type	Filettatura esterna/ External Thread	Filettatura interna/ Inner Thread	A mm	C mm	Note/Note
02448	MASCHIO-FEMMINA / MALE-FEMALE	1/4"	1/4"	12	19	ART,05138
02449	MASCHIO-FEMMINA / MALE-FEMALE	3/8"	3/8"	13	24	ART,05139
02450	MASCHIO-FEMMINA / MALE-FEMALE	1/2"	1/2"	14	27	ART,05140
19093	FEMMINA-FEMMINA / FEMALE-FEMALE	-	3/8"		24	ART,05139

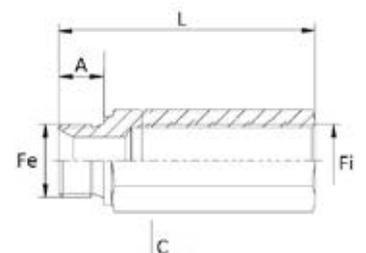

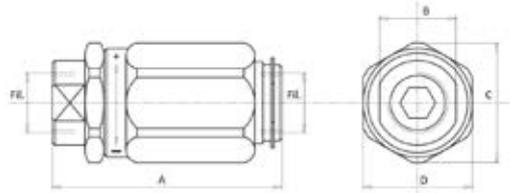
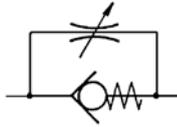
VALVOLA DI STROZZAMENTO UNIDIREZIONALE A MANICOTTO
CLAPET D'ETRANGLEMENT REGLABLE, A SPHERE, UNIDIRECTIONNEL
CLOSING ONE WAY BALL VALVE
KUGELRÜCKSCHLAGVENTIL
VALVULA ESTRANGULADOR CON ANTIRATORNO UNIDIRECCIONAL

Funzionamento: Il flusso libero é consentito in una direzione attraverso la valvola unidirezionale.

La valvola a spillo limita a chiude il flusso do ritorno in modo da ottenere la regolazione di velocità.

Fuctioning: The free flow is allowed in one direction throug one -way valve the pin valve limits or closed return flow in order to regulate the speed.

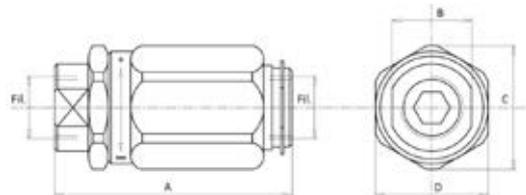
Art./Ref.	Pressione max (bar)/Pression max (bar)	Capacità LT/Capacity LT	Filettatura interna/Inner Thread	A mm	B mm	C mm	D mm
05292	300	20	1/4"	66,5	19	34	30
04215	300	45	3/8"	73	24	36	32
04216	300	70	1/2"	80	27	42	38

VALVOLA DI STROZZAMENTO BIDIREZIONALE A MANICOTTO
CLAPET D'ETRANGLEMENT REGLABLE, A SPHERE, BIDIRECTIONNEL
CLOSING BALL VALVE
VERSTELLBARES KUGELRÜCKSCHLAGVENTIL
ESTANGULADOR BIDIRECCIONAL

Funzionamento: Una valvola a spillo (regolata da un pomello o da una ghiera), regola la portata nella direzione della freccia limitando la velocità.

Fuctioning: A pin valve (regulated by a knob or by bush) regulates the delivery in the arrow direction limiting the speed.

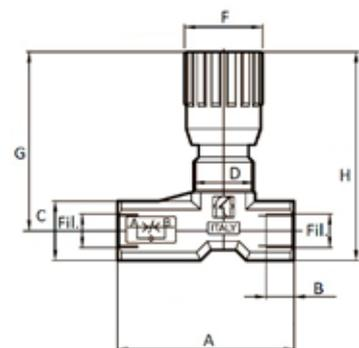
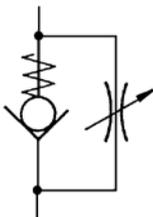
Art./Ref.	Pressione max (bar)/Pression max (bar)	Capacità LT/Capacity LT	Filettatura esterna/External Thread	Filettatura interna/Inner Thread	A mm	B mm	C mm	D mm
09217	300	20	1/4"	1/4"	66,5	19	34	30
09218	300	45	3/8"	3/8"	73	24	36	32
09219	300	70	1/2"	1/2"	80	27	42	38

REGOLATORE DI FLUSSO UNIDIREZIONALE
REGULATEUR DE DEBIT UNIDIRECTIONNEL
ONEWAY FLOW CONTROL VALVES
EINSEITIGES FLUSSREGELVENTIL
REGULADOR UNIDIRECCIONAL

Funzionamento: Seguire quello della valvola di strozzamento unidirezionale a manicotto.

Notes: Fuctioning: Follow the instructions showed in the closing one-way ball valve.

Art./Ref.	Pressione max (bar)/Pression max (bar)	Capacità LT/Capacity LT	Filettatura interna/Inner Thread	A mm	B mm	C mm	D mm	F mm	G mm	H mm
04198	350	15	1/4"	56	12	17	M17x1	22	52,5	61
04199	350	30	3/8"	64,5	13	22	M20x1	27	63	74
04200	350	50	1/2"	87	16	27	M25x1,5	33	72	85,5

REGOLATORE DI FLUSSO BIDIREZIONALE

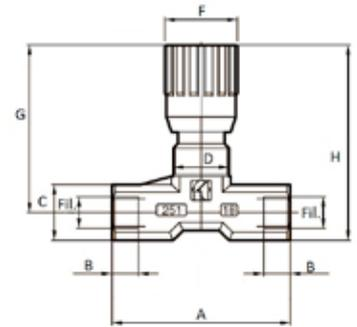
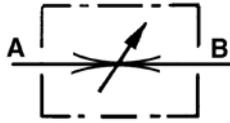
REGULATEUR DE DEBIT BIDIRECTIONEL
 FLOW CONTROL VALVES
 BEIDSEITIGES FLUSSREGELVENTIL
 REGULADOR BIDIRECCIONAL



Funzionamento: Seguire quello della valvola di strozzamento bidirezionale a manicotto.
Fuctioning: Follow the instructions showed in the closing daulex ball valve.

Art./Ref.	Pressione max (bar)/ Pression max (bar)	Capacità LT/ Capacity LT	Filettatura interna/ Inner Thread	A mm	B mm	C mm	D mm	F mm	G mm	H mm
04185	350	15	1/4"	46	12	17	M17x1	22	52,5	61
04186	350	30	3/8"	55	13	22	M20x1	27	63	74
04187	350	50	1/2"	70	16	27	M25x1,5	33	72	85,5

REGOLATORE DI FLUSSO UNIDIREZIONALE

REGULATEUR DE DEBIT UNIDIRECTIONNEL
 ONEWAY FLOW CONTROL VALVES
 EINSEITIGES FLUSSREGELVENTIL
 REGULADOR UNIDIRECCIONAL

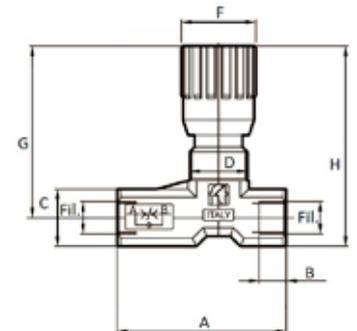
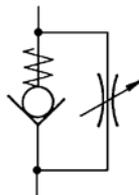

Note: Funzionamento: Seguire quello della valvola di strozzamento unidirezionale a manicotto.
Notes: Fuctioning: Follow the instructions showed in the closing one-way ball valve.

Art./Ref.	Pressione max (bar)/ Pression max (bar)	Capacità LT/ Capacity LT	Filettatura interna/ Inner Thread	A mm	B mm	C mm	D mm	F mm	G mm	H mm
37959	210	15	1/4"	56	12	17	M17x1	22	52,5	61
37960	210	30	3/8"	64,5	13	22	M20x1	27	63	74
37961	210	50	1/2"	87	16	27	M25x1,5	33	72	85,5

REGOLATORE DI FLUSSO BIDIREZIONALE

REGULATEUR DE DEBIT BIDIRECTIONEL
 FLOW CONTROL VALVES
 BEIDSEITIGES FLUSSREGELVENTIL
 REGULADOR BIDIRECCIONAL

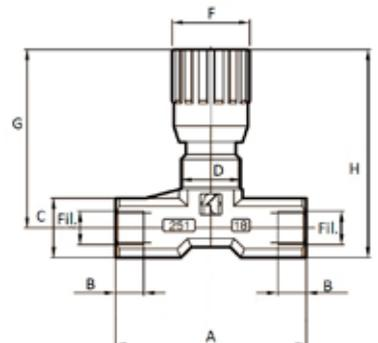
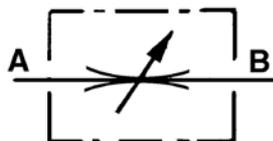

Note: Funzionamento: Seguire quello della valvola di strozzamento bidirezionale a manicotto.
Notes: Fuctioning: Follow the instructions showed in the closing daulex ball valve.

Art./Ref.	Pressione max (bar)/ Pression max (bar)	Capacità LT/ Capacity LT	Filettatura interna/ Inner Thread	A mm	B mm	C mm	D mm	F mm	G mm	H mm
37962	210	15	1/4"	46	12	17	M17x1	22	52,5	61
37963	210	30	3/8"	55	13	22	M20x1	27	63	74
37964	210	50	1/2"	70	16	27	M25x1,5	33	72	85,5

VALVOLA PRIORITARIA TARATURA REGOLABILE

VALVE PRIORITAIRE

PRIORITY VALVE

VORZUG - VENTIL

VALVULA PRIORITARIA CON TARA REGOLABILE

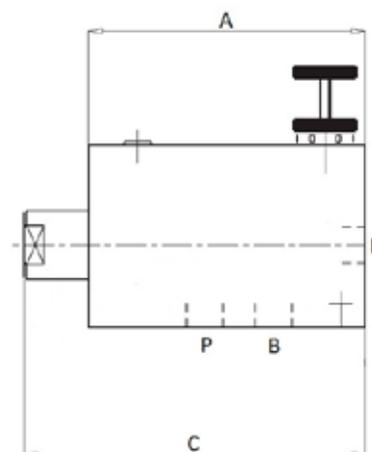
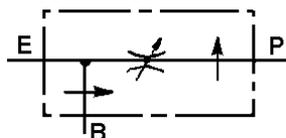
Note:

QE = portata max in entrata "E"

QP = portata max in uscita "P"

Valvola per la regolazione flusso

Con portata eccedente a scarico molto usata nella variazione della velocità di cilindri e motori orbitali.

Funzionamento:

Sono valvole regolatrici di portata con sistema prioritario a taratura regolabile.

Assicurano il flusso costante prioritario e consentono l'utilizzazione del flusso in eccesso per un secondo circuito.

Notes:

The priority flow is adjustable and is kept constant.

The exceding flow can be used for 1 more circuit, or sent to the tank.

QE = inlet max flow "E" QP = outlet max flow "P"

Art./Ref.	Capacità LT/ Capacity LT	Filettatura interna/ Inner Thread	Pressione max (bar)/ Pression max (bar)	A mm	C mm	F mm	G mm	H mm
05295	60/50	3/8"	350	121	147	35	35	80
05296	80/60	1/2"	350	121	147	35	35	80

REGOLATORE DI FLUSSO PRORITARIO (CORPO IN GHISA)

REGULATEUR DE FLUXE PRIORITAIRE (CORP EN FONT)

PRIORITY ADJUSTER (CAST IRON HOUSING)

FLUSSREGELVENTIL (AUS GUSS)

REGULATOR DE FLUJO (CUERPO DE FUNDICIÓN)



Funzionamento: Il flusso prioritario è regolabile ed è mantenuto costante. Il flusso eccedente può alimentare un secondo circuito, o essere mandato in serbatoio.

Warning datas: The priority flow is adjustable and is kept constant. The exceding flow can be used for 1 more circuit, or sent to the tank.

Art./Ref.	Capacità LT/Capacity LT	Filettatura esterna/External Thread
12297	50	1/2"

REGOLATORE DI FLUSSO VERTICALE IN GHISA

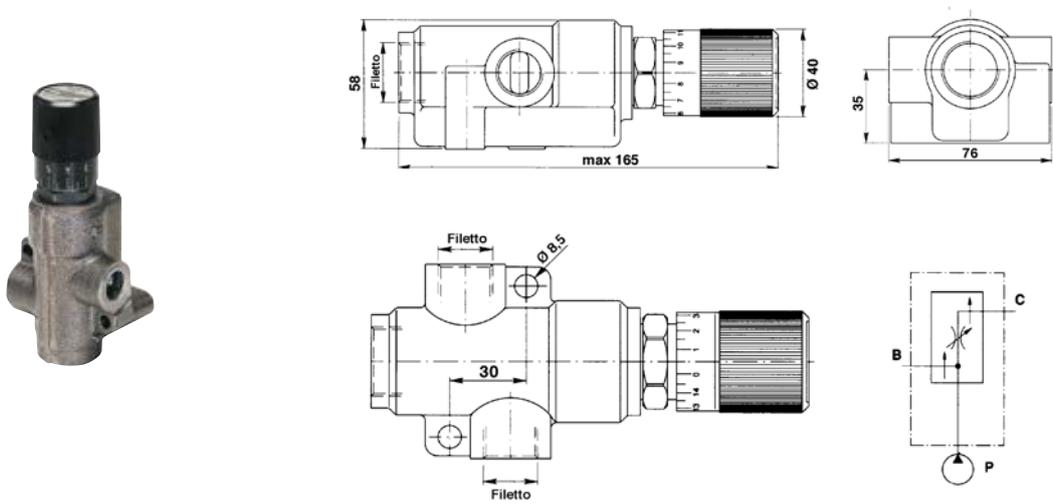
REGULATEUR DE DEBIT VERTICAL EN FONTE
 VERTICAL FLOW REGULATOR MADE OF CAST IRON
 FLUSSREGLER AUS GUSSEISEN SENKRECHT
 REGULADOR DE FLUJO, VERTICAL, DE FUNDICIÓN



Art./Ref.	Pressione max (bar)/ Pression max (bar)	Capacità LT/ Capacity LT	Filettatura esterna/ External Thread	Filettatura interna/ Inner Thread
17625	350	80	3/4"	1/2"

DIVISORE DI FLUSSO A TARATURA FISSA

DIVISEUR DE DEBIT
 FLOW DIVIDERS
 ÖLSTROMVERTEILER EINFACHWIRKEND
 DIVISOR CON TARA FIJA

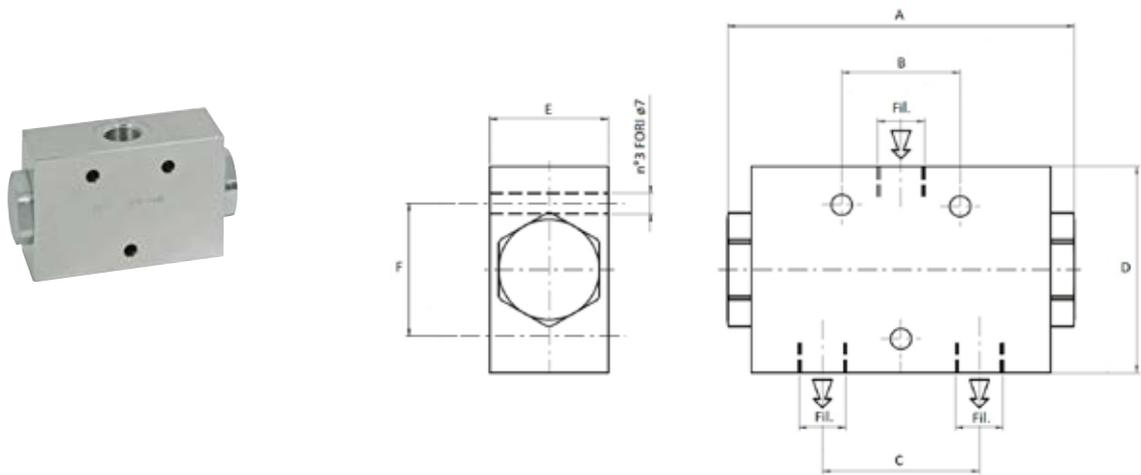

Note: Funzionamento: La portata della pompa viene divisa in parti uguali indipendentemente dalla pressione. Nella direzione inversa riuniscono il flusso.
Notes: Fuctioning: The pump delivery is divided in 2 equal shares aside from the pressure. In the opposite direction they re - unite again the flow.

Art./Ref.	Pressione max (bar)/ Pression max (bar)	Capacità LT/ Capacity LT	Filettatura interna/ Inner Thread	A mm	B mm	C mm	D mm	E mm	F mm
19439	250	6-10 LT	3/8"	117	40	53	70	40	45
19444	250	10-20 LT	3/8"	117	40	53	70	40	45
05297	250	25-40 LT	1/2" - 3/8"	117	40	53	70	40	45

RUBINETTI A SFERA A 2 VIE

ROBINETS A SPHERE A 2 VOIES
 BALL TAP 2 WAY BALL TAPS
 2 - WEGE - KUGELHÄHNE
 VALVULA ZUTAS

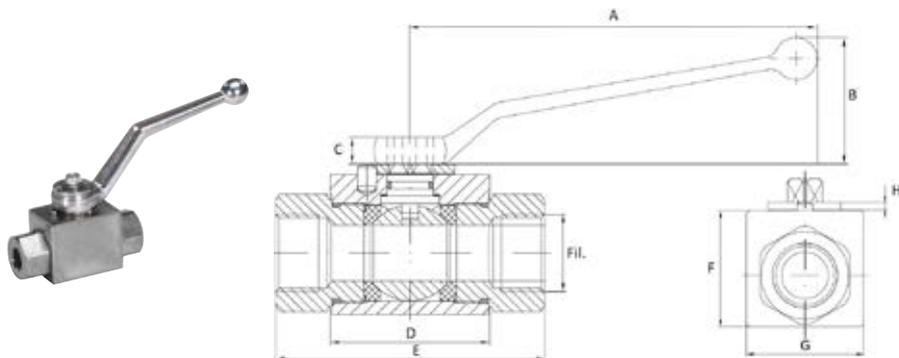

Art./Ref.	Pressione max (bar)/ Pression max (bar)	Filettatura interna/ Inner Thread	Filettatura esterna/ External Thread	Note/Note	A mm	B mm	C mm	D mm	E mm	F mm	G mm	H mm
05176	500	1/4"	-	-	107	36	8,7	36,2	69	32	26	3
05177	500	3/8"	-	-	107	36	8,7	43,2	73	38	32	3
05178	500	1/2"	-	-	107	36	8,7	48,2	85	40	35	3
50155	500	-	14X1,5	8L	107	36	8,7	36,2	69	32	26	3
50156	500	-	16X1,5	10L	107	36	8,7	36,2	71	32	26	3
50157	500	-	18X1,5	12L	107	36	8,7	43,2	71	38	32	3

RUBINETTI A SFERA A 3 VIE

ROBINETS A SPHERE A 3 VOIES
 BALL TAP 3 WAY BALL TAPS
 3 - WEGE - KUGELHÄHNE
 DESUIADOR DE 3 VIAS



Art./Ref.	Pressione max (bar)/ Pression max (bar)	Filettatura interna/ Inner Thread	A mm	B mm	C mm	D mm	E mm	F mm	G mm	H mm	Lunghezza mm/ Lenght mm
10809	400	1/4"	107	36	8,7	36	69	32	26	3	32
10810	400	3/8"	107	36	8,7	43	73	38	32	3	35
10811	350	1/2"	107	36	8,7	48	85	40	35	3	37

VALVOLE ELETTRICHE A 2 VIE

CLAPET ELECTRIQUE
 ELECTRICAL VALVES 2 WAYS
 2-WEGE-ELEKTROVENTIL GESCHLOSSEN
 VALVULA ELECTRICA 2 VIE

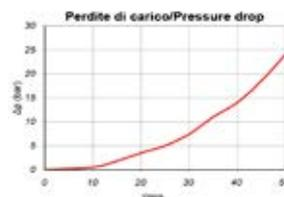
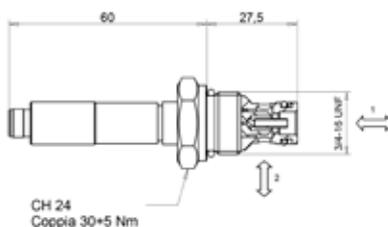
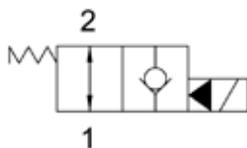

Art./Ref.	Tipo/Type	Pressione max (bar)/ Pression max (bar)	Capacità LT/ Capacity LT	Volt/Volt	Note/Notes
89310	2 VIE / 2 WAYS	310	35	12VDC	NORMALMENTE APERTA / NORMALLY OPEN
89311	2 VIE / 2 WAYS	310	35	24VDC	NORMALMENTE APERTA / NORMALLY OPEN
89312	2 VIE / 2 WAYS	310	35	12VDC	NORMALMENTE CHIUSA / NORMALLY CLOSED
89313	2 VIE / 2 WAYS	310	35	24VDC	NORMALMENTE CHIUSA / NORMALLY CLOSED

VALVOLE ELETTRICHE A 2 VIE NORMALMENTE CHIUSA A DOPPIA TENUTA

CLAPET ELECTRIQUE 2 VOIES NORMALEMENT FERMEE A DOUBLE ETANCHEITE
 ELECTRICAL VALVES 2 WAYS NORMALLY CLOSED DOUBLE BLOCKING
 2-WEGE-ELEKTROVENTIL GESCHLOSSEN MIT DOPPELDICHTUNG
 VALVULA ELECTRICA SELLO DOBLE NORMALMENTE CERRADO

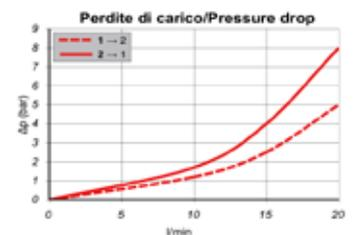
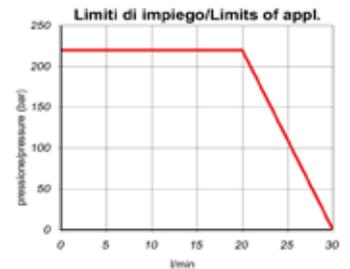
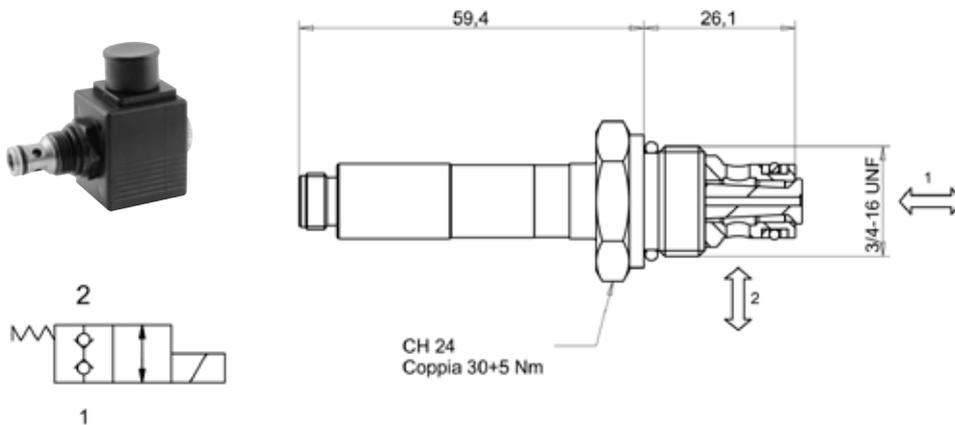

Art./Ref.	Tipo/Type	Pressione max (bar)/ Pression max (bar)	Capacità LT/ Capacity LT	Volt/Volt	Note/Notes
89314	2 VIE / 2 WAYS	220	20	12VDC	NORMALMENTE CHIUSA DOPPIA TENUTA / NORMALLY CLOSED DOUBLE BLOCKING/
89315	2 VIE / 2 WAYS	220	20	24VDC	NORMALMENTE CHIUSA DOPPIA TENUTA / NORMALLY CLOSED DOUBLE BLOCKING

VALVOLE ELETTRICHE A 3 VIE

CLAPET ELECTRIQUE
 ELECTRICAL VALVES 3 WAYS
 3-WEGE-ELEKTROVENTIL GESCHLOSSEN
 VALVULA ELECTRICA 3 VIE

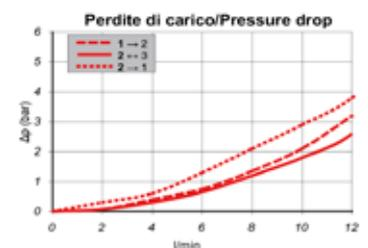
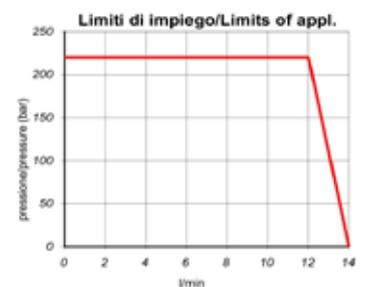
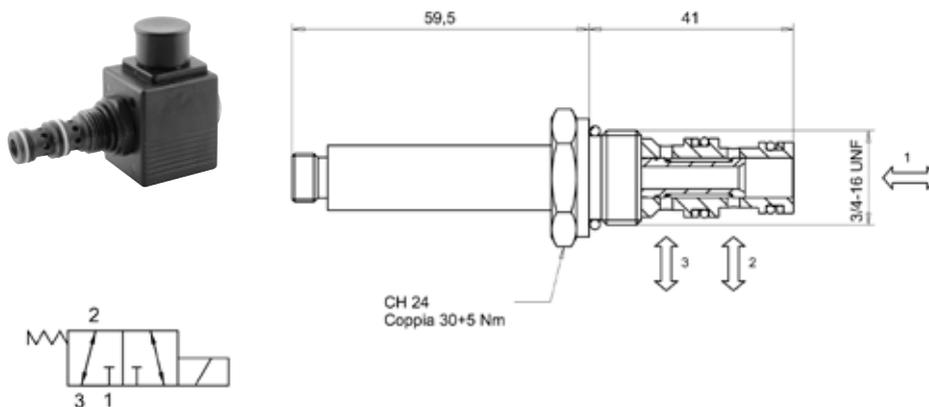

Art./Ref.	Tipo/Type	Pressione max (bar)/Pression max (bar)	Capacità LT/Capacity LT	Volt/Volt
89316	3 VIE / 3 WAYS	220	12	12VDC
89317	3 VIE / 3 WAYS	220	12	24VDC
89318	3 VIE / 3 WAYS	220	35	12VDC
89319	3 VIE / 3 WAYS	220	35	24VDC

CORPI IN ALLUMINIO PER VALVOLE ELETTRICHE

BLOCS POUR CLAPET ELECTRIQUE
 ALLUMINUM BODIES FOR ELECTRICAL VALVES
 ALUMINIUM STANDARDGEHAUSE
 CUERPO PARA VALVULA ELECTRICA

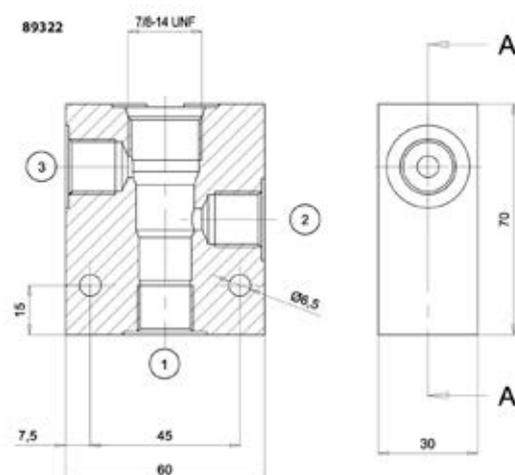
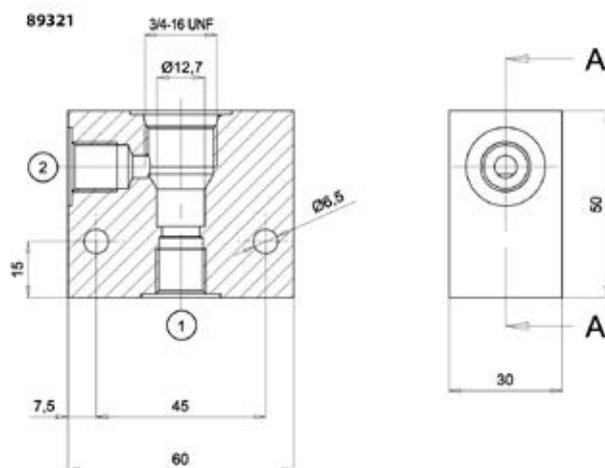
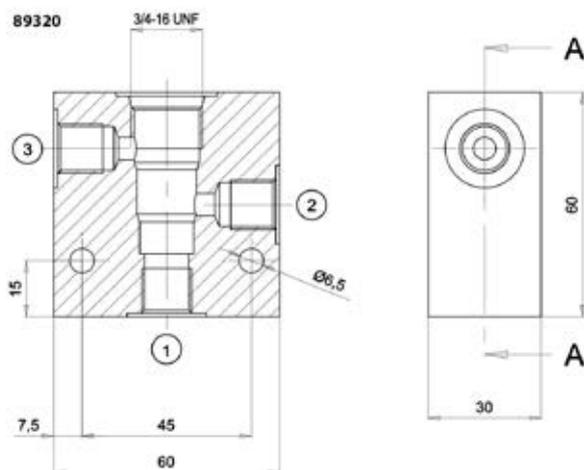

Art./Ref.	Tipo/Type	Filettatura interna/Inner Thread	Note/Notes
89320	2 VIE / 2 WAYS	3/8"	CORPO PER ARTICOLI / BODY FOR CODES: 89310, 89311, 89312, 89313, 89314, 89315
89321	3 VIE / 3 WAYS	3/8"	CORPO PER ARTICOLI / BODY FOR CODES: 89316, 89317
89322	3 VIE / 3 WAYS	3/8"	CORPO PER ARTICOLI / BODY FOR CODES: 89318, 89319

VALVOLA DI SEQUENZA

VALVES DE SEQUENCE

SEQUENCE VALVE

DRUCKFOLGE VENTILE

VALVULA DE SECUENCIA

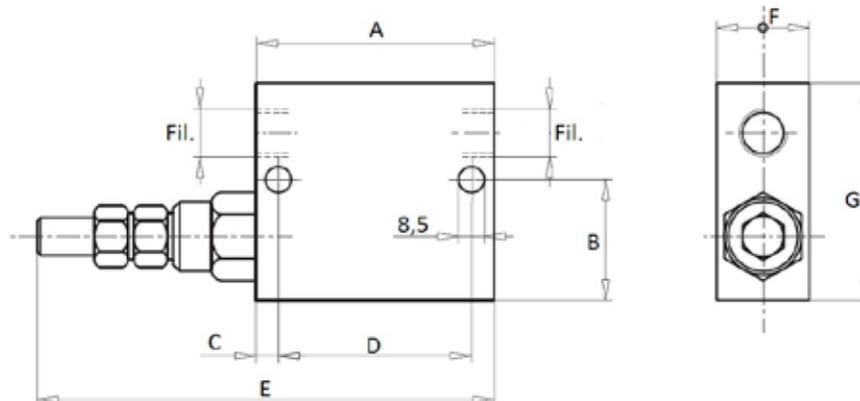

Valvole di sequenza: sono impiegate per eseguire movimenti in sequenza di due o più¹ cilindri al raggiungimento di una data pressione (taratura valvola).

Sequence valves: Used for sequential movements of 2 or more cylinders once reached the required pressure (valve setting).

Art./Ref.	Pressione max (bar)/ Pression max (bar)	Capacità LT/ Capacity LT	Filettatura interna/ Inner Thread	A mm	B mm	C mm	D mm	E mm	F mm	G mm
16874	350	35	3/8"	74	39	7	55	146	30	70

PISTONE PER FRENOTURA IDRAULICA: STELO Ø 25, CORSA MM. 70, COMPLETO DI MOLLA DI RICHIAMO INTERNA

VERIN FREINAGE HYDRAULIQUE: TIGE Ø 25, COURSE 70 MM., COMPLÈTE DE RESSORT

HYDRAULIC BREAKING CYLINDER: ROD Ø 25, STROKE 70 MM., WITH RETURN SPRING INSIDE

BREMSHYDRAULIKZYLINDER: KOLBEN Ø 25, HUB 70 MM., KPL. MIT INNENRÜCKZUGSFEDER

PISTON DE FRENO HIDRAÚLICO

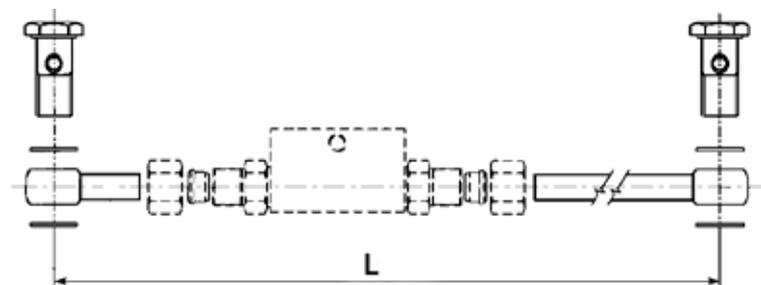

Art./Ref.	Filettatura interna/Inner Thread
01578	3/8"

VALVOLE DI BLOCCO PILOTATE A DOPPIO EFFETTO COMPLETE DI TUBO E RACCORDERIA PER L'APPLICAZIONE AL TERZO PUNTO A REGOLAZIONE IDRAULICA.
CLAPET DE BLOCAGE
DOUBLE VALVES COMPLETE WITH TUBES AND COUPLINGS FOR HYDRAULIC TOP LINKS.
DOPPELWIRKENDES SPERRVENTIL KPL. MIT ROHRLEITUNGEN.
VÁLVULA DE BLOQUEO DOBLE EFECTO CON TUBO Y RACORES PARA APLICACIÓN TERCER PUNTO CON AJUSTAMIENTO HIDRÁULICO

Art./Ref.	L mm/L mm	Brand	Applicazione/Application
05190	220	A.M.A.	06010
05159	255	A.M.A.	06003, 06007
05191	270	A.M.A.	06011, 06014
05165	325	A.M.A.	06004, 06008
05193	340	A.M.A.	06012, 06015
05179	445	A.M.A.	06005, 06009
05194	460	A.M.A.	06013

1.2.6 Motori Orbitali

Hydraulic motors



TABELLA DI COMPARAZIONE

Comparison table

AMA	DANFOSS
KM	OMM
KP	OMP
KR	OMR
KS	OMS



Ricambi & accessori per macchine agricole

SPARE PARTS & ACCESSORIES FOR AGRICULTURAL MACHINE

Tutti gli articoli della presente sezione, prodotti da AMA SPA e/o da terzi per conto di AMA, sono adattabili ("non originali") alle marche indicate ai sensi di quanto previsto dal REG. CE n. 1400/2002. I diritti sui marchi citati appartengono ai legittimi proprietari ed il loro uso ha l'esclusiva finalità di consentire all'utilizzatore la comparazione dei diversi prodotti. All items of this section, manufactured by AMA SPA and/or any third party on behalf of AMA, are adaptable ("non-original") to the brands listed under the provisions of the REG. CE n. 1400/2002. The rights on the trademarks belong to their respective owners and their usage is only aimed to allow the user to compare different products.

MOTORI ORBITALI (KM)

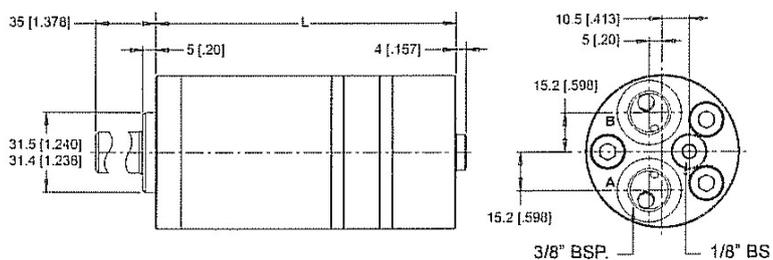
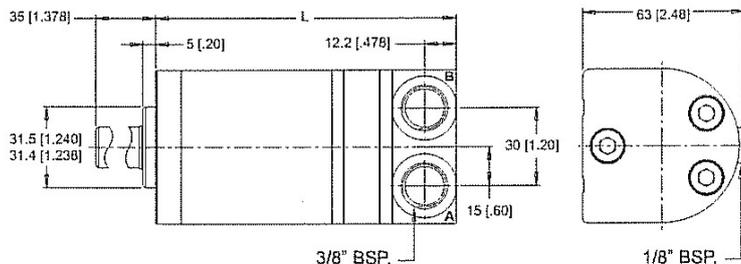
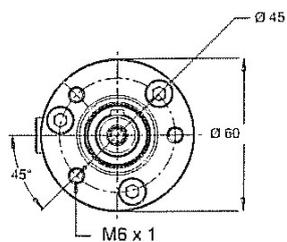
 MOTEUR HYDRAULIQUE (KM)
 HYDRAULIC MOTORS (KM)
 KM VENTILMOTOREN
 MOTOR HIDRÁULICO (KM)

16mm

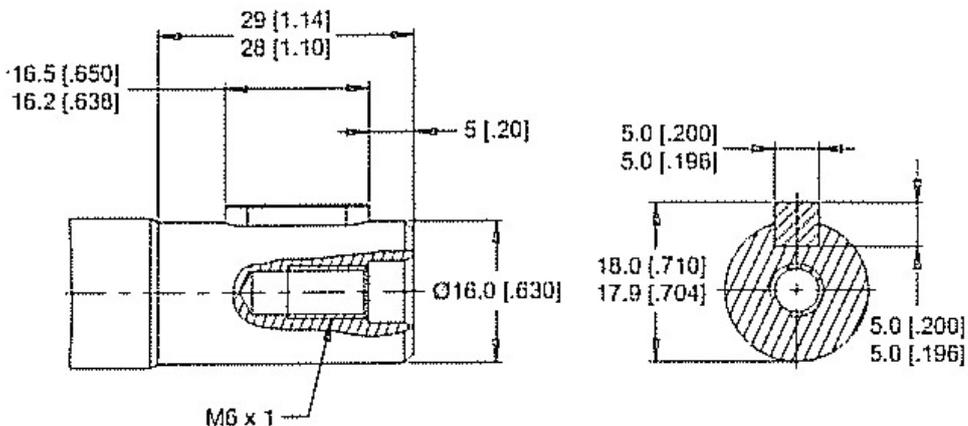

Art./Ref. 81192

 KIT GUARNIZIONI PER MOTORI KM
 GASKETS KIT FOR MOTOR KM

Art./Ref.	Modello/Model	Velocità max/Max speed	Cilindrata/Displacement	Lungh. mm/Lenght mm	Coppia continua/Continuous torque	Coppia intermittente/Intermittent torque	KW continua/Continuous KW	KW intermittente/Intermittent KW	Portata/Capacità/Flow/Capacity	Pressione max (bar)/Pression max (bar)	Note/Notes
76036	KM8	1864	8.4	106	11	14	2.2	2.8	16	100	-
76037	KM12	1521	13.1	108	17	22	2.7	3.5	20	100	-
76038	KM20	989	20.1	110	26	34	2.7	3.6	20	100	-
76039	KM32	622	31.8	115	40	55	2.6	3.6	20	100	-
76069	KM32	622	31.8	115	40	55	2.6	3.6	20	100	ATTACCHI LATERALI SIDE PORTS
76040	KM40	495	40.2	118	49	64	2.6	3.4	20	100	-
76041	KM50	395	50.3	123	44	72	1.8	3	20	70	-

MOTORI ORBITALI KP

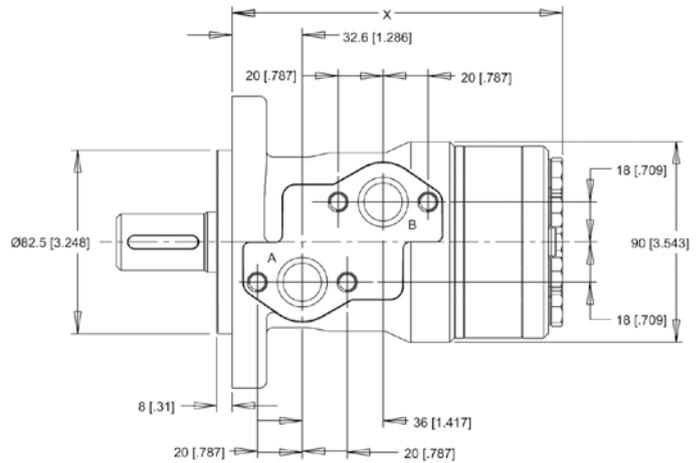
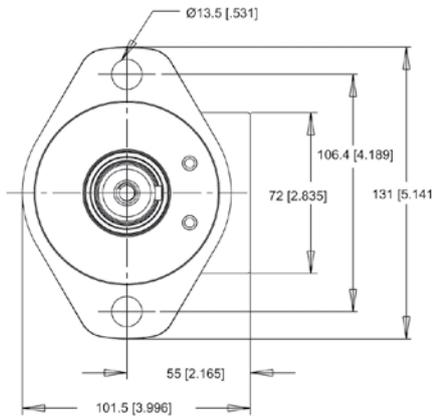
MOTEUR HYDRAULIQUE (KP)
 HYDRAULIC MOTORS (KP)
 KP VENTILMOTOREN
 MOTOR HIDRÁULICO (KP)



25mm Straight
 Max. Torque: 678 Nm [6000 lb-in]

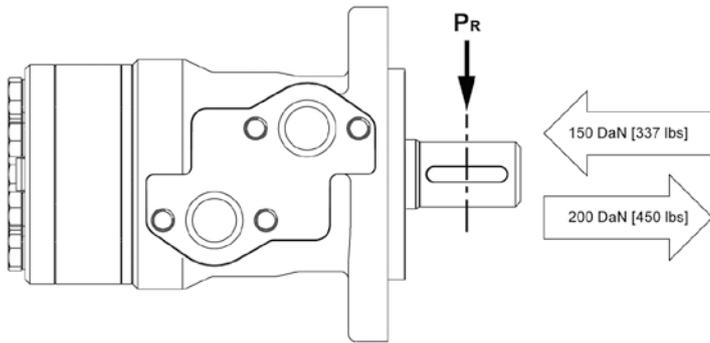
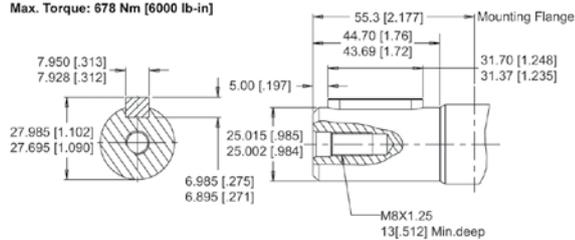

PERMISSIBLE SHAFT SIDE LOAD / AXIAL LOAD

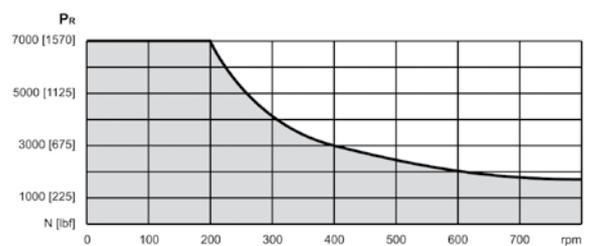

Art./Ref. 76137

KIT GUARNIZIONI PER MOTORI KP
 GASKETS KIT FOR MOTOR KP

Art./Ref.	Modello/Model	Velocità max/Max speed	Cilindrata/Displacement	Lunghezza mm/Lenght mm	Coppia continua/Continuous torque	Coppia intermittente/Intermittent torque	KW continua/Continuous KW	KW intermittente/Intermittent KW	Portata/Capacità/Flow/Capacity	Pressione max (bar)/Pression max (bar)
76002	KP50	1208	50	134.4	91	108	11.7	13.9	60	140
76003	KP80	896	78	138.4	164	183	15.6	17.4	60	160
76004	KP100	728	96	140.9	195	213	15.1	16.5	60	160
76005	KP125	559	125	142.4	258	278	15.3	16.5	60	160
76006	KP160	452	154	148.9	321	362	15.4	17.4	60	160
76007	KP200	367	190	153.9	380	420	14.8	16.4	60	150
76008	KP250	291	240	160.4	445	557	13.8	17.2	60	140
76009	KP315	228	303	168.9	460	602	11.1	14.6	60	120
76010	KP400	155	388	180	488	625	8	10.3	60	95

MOTORI ORBITALI (KP) SAE 6B

MOTEUR HYDRAULIQUE (KP) SAE 6B

HYDRAULIC MOTORS (KP) SAE 6B

KP SAE 6B VENTILMOTOREN

MOTOR HIDRÁULICO (KP) SAE 6B

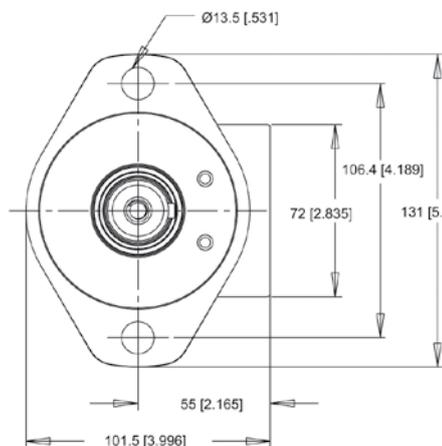

SAE 6B

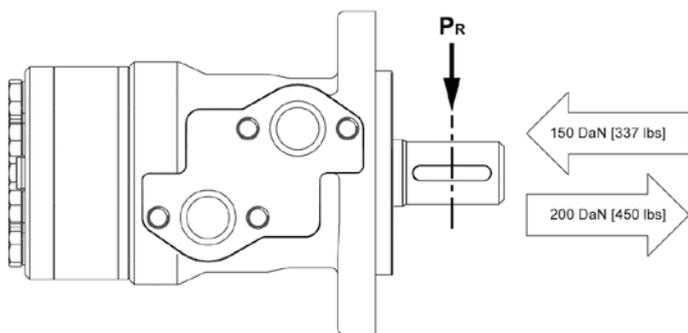
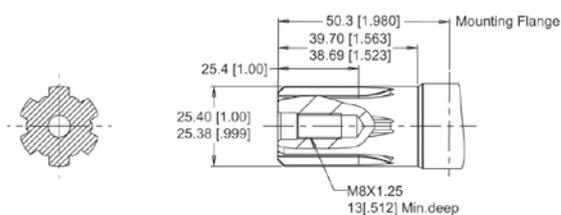
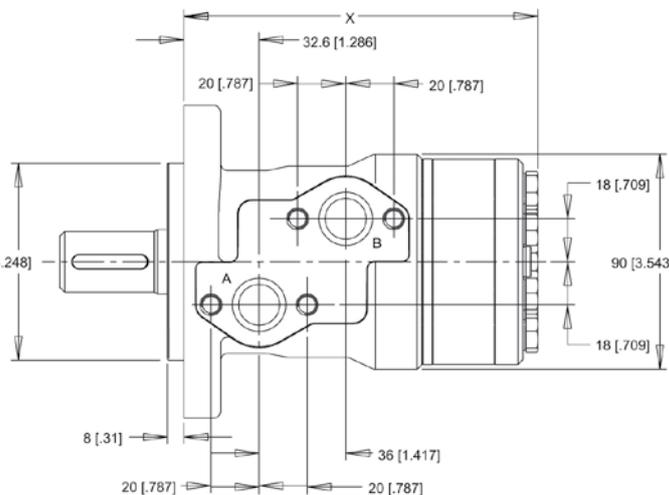

PERMISSIBLE SHAFT SIDE LOAD / AXIAL LOAD

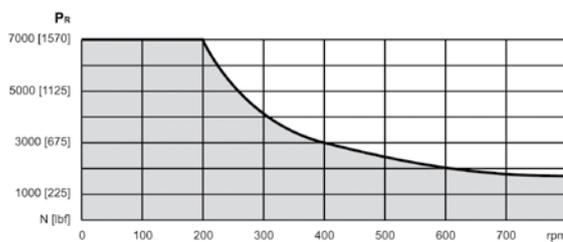
Art./Ref. 76137

KIT GUARNIZIONI X MOTORI KP

GASKETS KIT FOR MOTOR KP

Art./Ref.	Modello/ Model	Velocità max/ Max speed	Cilindrata/ Displacement	Lunghezza mm/ Length mm	Coppia continua/ Continuous torque	Coppia intermittente/ Intermittent torque	KW continua/ Continuous KW	KW intermittente/ Intermittent KW	Portata/ Capacità/Flow/ Capacity	Pressione max (bar)/ Pression max (bar)
76019	KP50SAE6B	1208	50	134.4	91	108	11.7	13.9	60	140
76020	KP80SAE6B	896	78	138.4	164	183	15.6	17.4	60	160
76021	KP100SAE6B	728	96	140.9	195	213	15.1	16.5	60	160
76023	KP160SAE6B	452	154	148.9	321	362	15.4	17.4	60	160
76024	KP200SAE6B	367	190	153.9	380	420	14.8	16.4	60	150
76025	KP250SAE6B	291	240	160.4	445	557	13.8	17.2	60	140
76026	KP315SAE6B	228	303	168.9	460	602	11.1	14.6	60	120
76027	KP400SAE6B	155	388	180	488	625	8	10.3	60	95

MOTORI ORBITALI (KR)

MOTEUR HYDRAULIQUE (KR)
 HYDRAULIC MOTORS (KR)
 KR VENTILMOTOREN
 MOTOR HIDRÁULICO (KR)

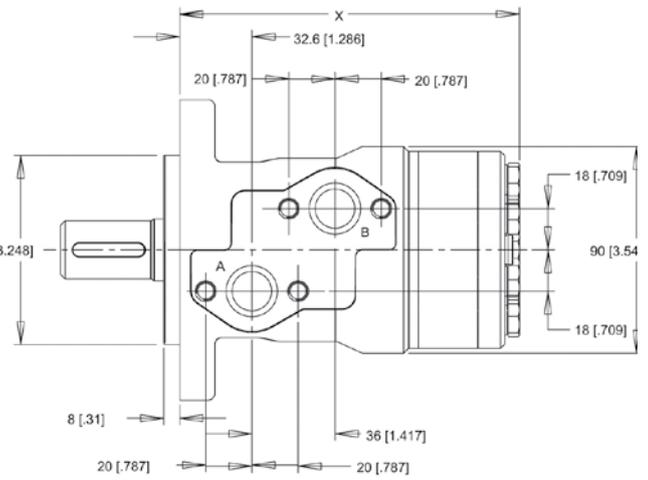
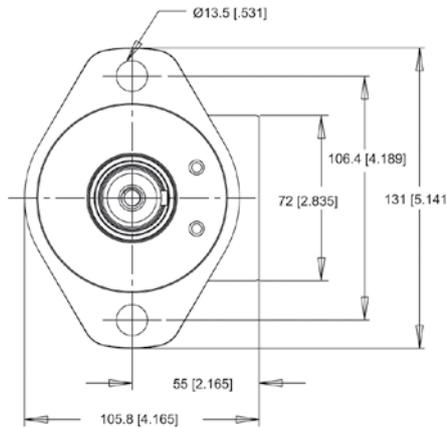

25mm

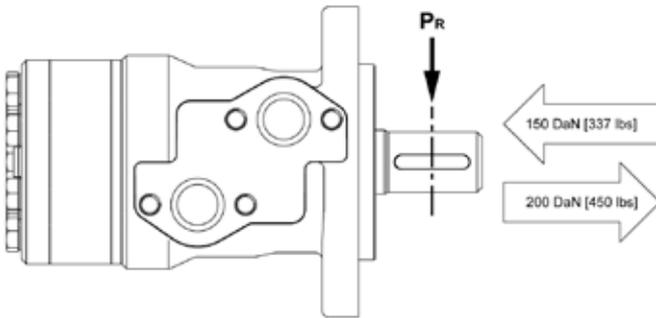
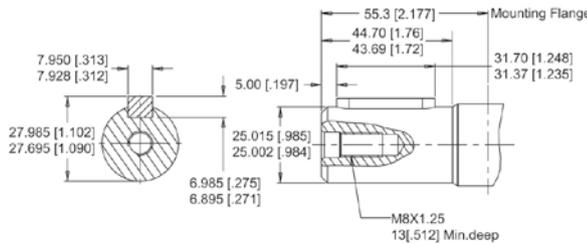

PERMISSIBLE SHAFT SIDE LOAD / AXIAL LOAD

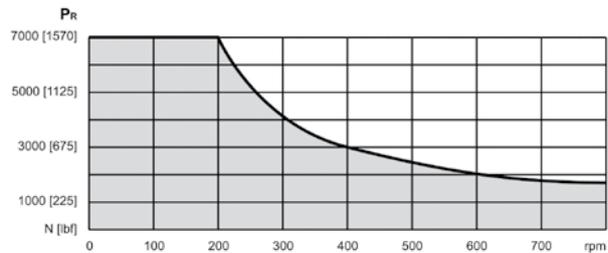

Art./Ref. 76138

KIT GUARNIZIONI X MOTORI KR
 GASKETS KIT FOR MOTOR KR

Art./Ref.	Modello/Model	Velocità max/Max speed	Cilindrata/Displacement	Lunghezza mm/Lenght mm	Coppia continua/Continuous torque	Coppia intermittente/Intermittent torque	KW continua/Continuous KW	KW intermittente/Intermittent KW	Portata/Capacità/Flow/Capacity	Pressione max (bar)/Pression max (bar)
82649	KR40	1116	40	138	93	123	11	14.6	45	155
76011	KR50	898	51	140	113	153	10.8	14.6	45	155
76012	KR80	765	80	145	196	238	15.9	19.3	61	172
76013	KR100	610	100	150	246	289	15.9	18.7	61	172
76014	KR125	472	129	156	316	375	15.9	18.8	61	172
76015	KR160	379	160	162	400	454	16.1	18.3	61	172
76016	KR200	308	198	169	462	544	15.1	17.8	61	172
76017	KR250	244	248	180	562	676	14.5	17.5	61	172
76018	KR315	188	322	194	526	664	10.5	13.3	61	138
84328	KR400	152	400	209	551	698	8.9	14.1	61	104

MOTORI ORBITALI (KS)

MOTEURS HYDRAULIQUES (KS)

HYDRAULIC - MOTORS (KS)

KS VENTILMOTOREN

MOTOR HIDRÁULICO (KS)

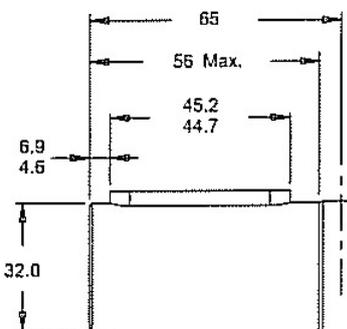
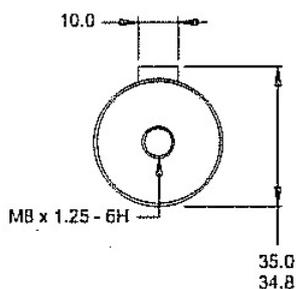
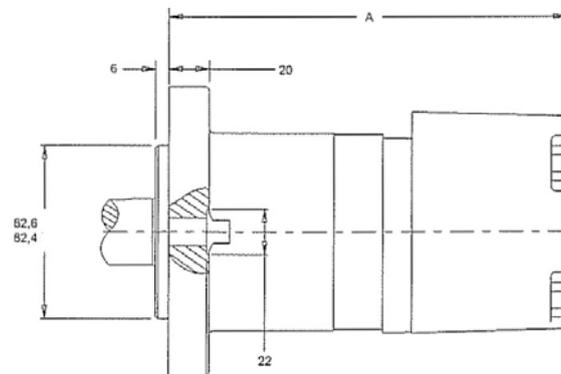
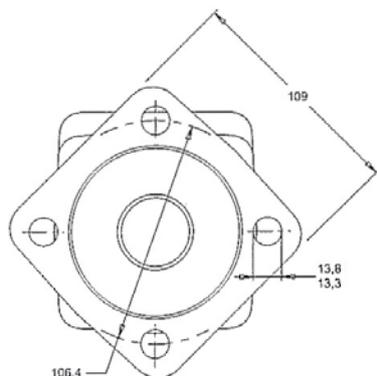

1/2" BSP.F 1/4" Drain Port

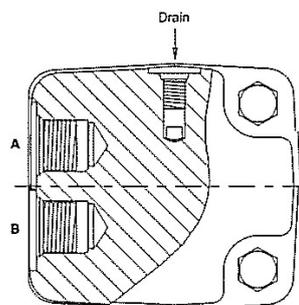
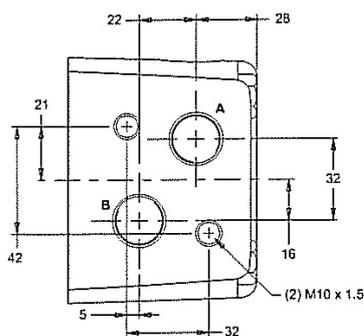
Art./Ref. 81240

KIT GUARNIZIONI X MOTORI KS

GASKETS KIT FOR MOTOR KS

Art./Ref.	Modello/ Model	Velocità max/ Max speed	Cilindrata/ Displacement	Lunghezza mm/ Length mm	Coppia continua/ Continuous torque	Coppia intermittente/ Intermittent torque	KW continua/ Continuous KW	KW intermittente/ Intermittent KW	Portata/ Capacità/ Flow/Capacity	Pressione max (bar)/Pression max (bar)
76028	KS80	870	79	185	207	286	19.1	26.4	61	207
76029	KS100	745	100	185	280	416	22.2	32.9	76	207
76030	KS125	580	129	190	370	550	22.8	33.9	76	207
76031	KS160	465	162	197	462	618	22.8	30.5	76	207
76032	KS200	375	202	204	576	768	23	30.6	76	207
76033	KS250	325	228	210	642	806	22.2	27.8	76	207
76034	KS315	235	325	228	789	1029	19.7	25.7	76	190
76035	KS400	190	399	228	816	1034	16.5	20.9	76	155

KIT GUARNIZIONI X MOTORI ORBITALI

KIT JOINTS POUR MOTEURS ORBITAL
SEAL KIT FOR ORBITROL MOTORS
DICHTUNGSSATZ FÜR MOTOREN
KIT JUNTAS PARA MOTORES

Art./Ref.	Note/Notes
81192	KIT GUARNIZIONI X MOTORI KM / GASKETS KIT FOR MOTOR KM
76137	KIT GUARNIZIONI X MOTORI KP / GASKETS KIT FOR MOTOR KP
76138	KIT GUARNIZIONI X MOTORI KR / GASKETS KIT FOR MOTOR KR
81240	KIT GUARNIZIONI X MOTORI KS / GASKETS KIT FOR MOTOR KS

BUSSOLA DI RIDUZIONE PER MOTORE ORBITALE SAE 6B

DOUILLE DE REDUCTION POUR MOTEUR ORBITAL SAE 6B
REDUCING BUSHING FOR SAE 6B HYDRAULIC MOTOR
REDUZIERBUECHSE FÜR OELMOTOR SAE 6B
TUERCA DE REDUCCIÓN DE MOTORES HIDRAULICOS SAE 6B



Art./Ref.	Lunghezza mm/Lenght mm	Tipo/Type
17489	50	SAE6B

BUSSOLA DI RIDUZIONE PER MOTORE ORBITALE

DOUILLE DE REDUCTION POUR MOTEUR ORBITAL
REDUCING BUSHING FOR HYDRAULIC MOTOR
REDUZIERBUECHSE FÜR OELMOTOR
TUERCA DE REDUCCIÓN DE MOTORES HIDRAULICOS

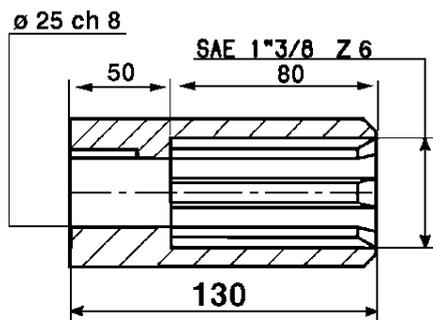

Art./Ref.	Lunghezza mm/Lenght mm	Tipo/Type
12613	130	$\varnothing 25 - 1"3$

RIDUTTORE GR2 PER MOTORI ORBITALI RHR E OMR DANFOSS

REDUCTEUR GR 2 POUR RHR ET OMR DANFOSS

REDUCTION GEAR GROUP 2 FOR RHR AND OMR DANFOSS

UNTERSETZUNGSGETRIEBE GR 2 FÜR VENTILMOTORE RHR UND OMR DANFOSS

REDUCTOR GR.2 PARA MOTORES PHR Y OMR

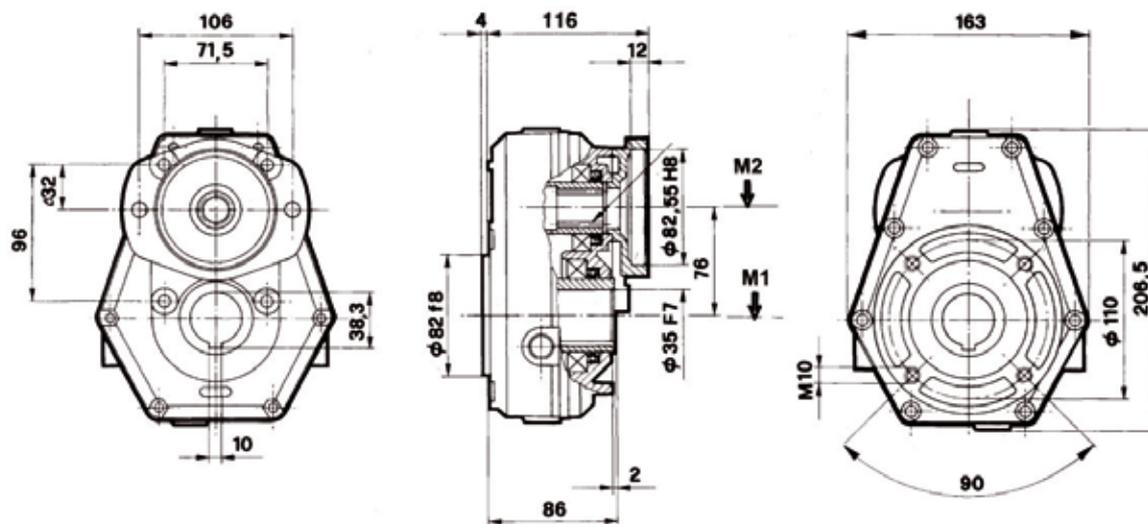

Art./Ref.	KW continua/Continuous KW	Rapporto di moltiplicazione/Ratio (increase)	Tipo/Type
04665	11	2:1	Ø25
04666	11	3:1	Ø25
16136	11	3:1	SAE 6B

1.2.7 Idroguide

Hydraulic steerings



Ricambi & accessori per macchine agricole

SPARE PARTS & ACCESSORIES FOR AGRICULTURAL MACHINE

Tutti gli articoli della presente sezione, prodotti da AMA SPA e/o da terzi per conto di AMA, sono adattabili ("non originali") alle marche indicate ai sensi di quanto previsto dal REG. CE n. 1400/2002. I diritti sui marchi citati appartengono ai legittimi proprietari ed il loro uso ha l'esclusiva finalità di consentire all'utilizzatore la comparazione dei diversi prodotti. All items of this section, manufactured by AMA SPA and/or any third party on behalf of AMA, are adaptable ("non-original") to the brands listed under the provisions of the REG. CE n. 1400/2002. The rights on the trademarks belong to their respective owners and their usage is only aimed to allow the user to compare different products.

IDROGUIDE CON VALVOLA INCORPORATA (K-PRODUCTS)

DIRECTIONS HYDRAULIQUES

STEERING UNITS WITH VALVES

HYDROLENKUNGEN MIT INNENVENTIL

IDROGUIDA CON VALVOLA INTERNA

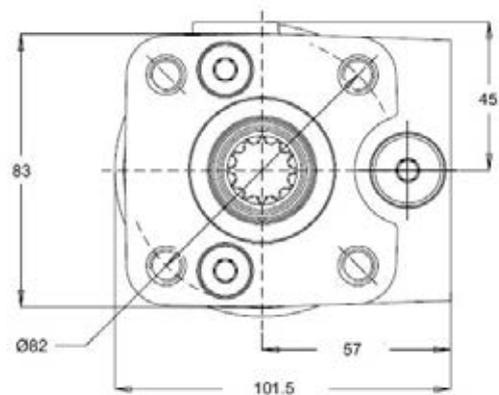
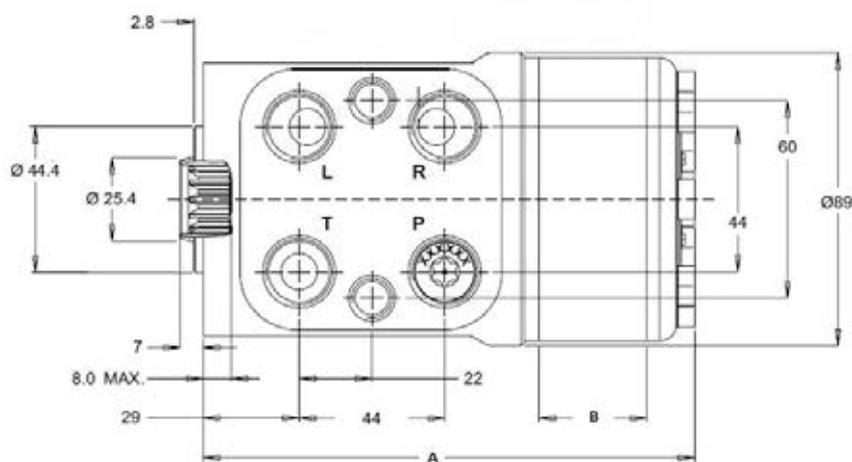
76139

KIT GUARNIZIONI X IDROGUIDE

76139

GASKETS KIT FOR STEERING

Art./Ref.	Cilindrata/ Displacement	A mm	B mm	Note/Note	Tipo/Type	Brand	Applicazione/Application
76042	50	122,9	6,5	Portata/Flow 5-12 lt/min.	OSPC 50 ON	-	-
76043	80	126,8	10,4	Portata/Flow 8-20 lt/min.	OSPC 80 ON	BCS - NIBBI	BCS, NIBBI
76044	100	129,4	13,0	Portata/Flow 8-20 lt/min.	OSPC 100 ON	LANDINI - FIAT - MASSEY FERGUSON	5143318,5143319,5143320, 10000,12500,13000,14500,5830, 5840,6030,6040,6550,6830,6840, 7550,7830,8550,8830, 3305002
76045	125	132,6	16,2	Portata/Flow 10-30 lt/min.	OSPC 125 ON	-	-
76065	160	137,2	20,8	Portata/Flow 15-40 lt/min.	OSPC 160 ON	-	-
76047	200	142,4	26,0	Portata/Flow 15-40 lt/min.	OSPC 200 ON	-	-
76048	250	148,9	32,5	Portata/Flow 20-60 lt/min.	OSPC 250 ON	-	-
76049	315	157,3	40,9	Portata/Flow 20-60 lt/min.	OSPC 315 ON	-	-

IDROGUIDE TIPO LS

DIRECTIONS HYDRAULIQUES TYPE LS (LOAD SENSING)
 HYDRAULIC STEERING TYPE LS (LOAD SENSING)
 HYDROLENKUNGEN TYP LS (LOAD SENSING)
 IDROGUIDA TIPO LS (LOAD SENSING)

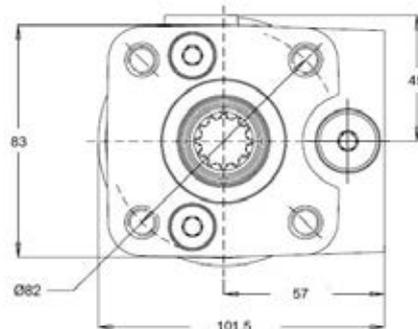
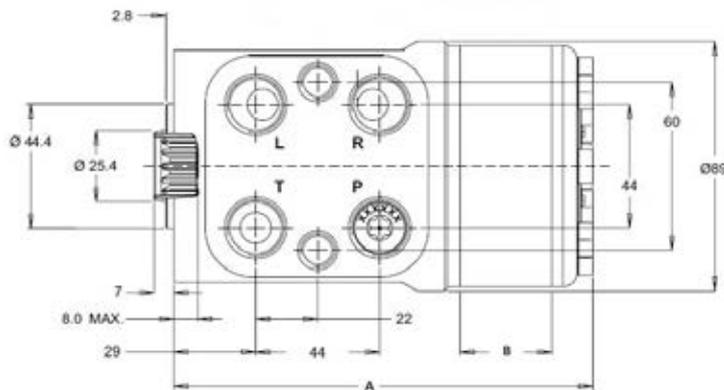
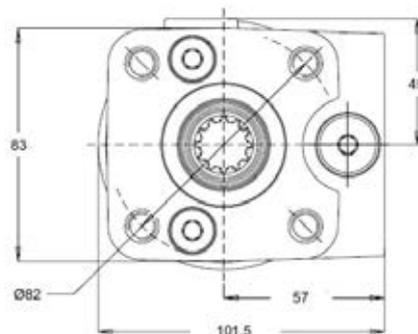
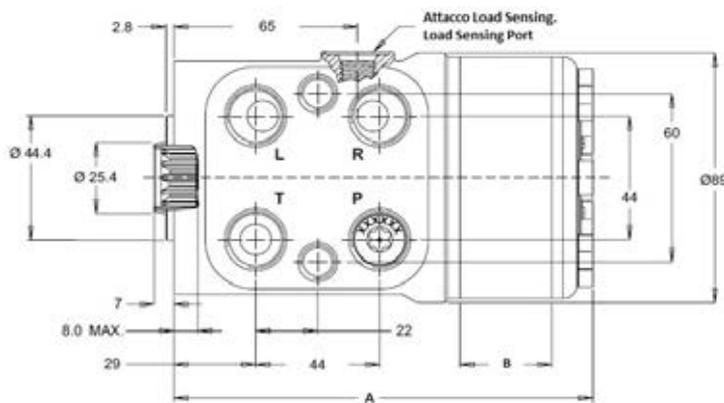
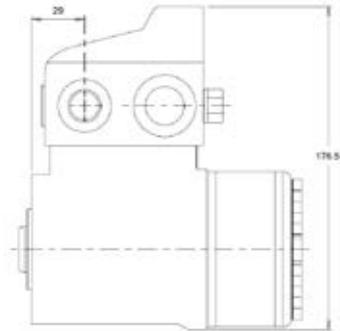

76139
 KIT GUARNIZIONI X IDROGUIDE

76139
 GASKETS KIT FOR STEERING

Art./Ref.	Modello/Model	Cilindrata/ Displacement	A mm	B mm	Note/Note	Tipo/Type	Brand	Applicazione/ Application
76050	MONTAGGIO IN LINEA - PIPE MOUNTING	80	126,8	10,4	Portata/Flow 8-20 lt/min.	OSPC 80 LS	A.M.A.	76060
76051	MONTAGGIO IN LINEA - PIPE MOUNTING	100	129,4	13,0	Portata/Flow 8-20 lt/min.	OSPC 100 LS	A.M.A.	76060
76052	MONTAGGIO IN LINEA - PIPE MOUNTING	160	137,2	20,8	Portata/Flow 15-40 lt/min.	OSPC 160 LS	A.M.A.	76060
76053	MONTAGGIO IN LINEA - PIPE MOUNTING	200	142,4	26,0	Portata/Flow 15-40 lt/min.	OSPC 200 LS	A.M.A.	76060
76054	MONTAGGIO IN LINEA - PIPE MOUNTING	315	157,3	40,9	Portata/Flow 20-60 lt/min.	OSPC 315 LS	A.M.A.	76060
76055	MONTAGGIO MODULARE - MODULARY MOUNTING	80	126,8	10,4	Portata/Flow 8-20 lt/min.	OSPC 80 LS	A.M.A.	76061
76056	MONTAGGIO MODULARE - MODULARY MOUNTING	100	129,4	13,0	Portata/Flow 8-20 lt/min.	OSPC 100 LS	A.M.A.	76061
76057	MONTAGGIO MODULARE - MODULARY MOUNTING	160	137,2	20,8	Portata/Flow 15-40 lt/min.	OSPC 160 LS	A.M.A.	76061
76058	MONTAGGIO MODULARE - MODULARY MOUNTING	200	142,4	26,0	Portata/Flow 15-40 lt/min.	OSPC 200 LS	A.M.A.	76061
76059	MONTAGGIO MODULARE - MODULARY MOUNTING	315	157,3	40,9	Portata/Flow 20-60 lt/min.	OSPC 315 LS	A.M.A.	76061

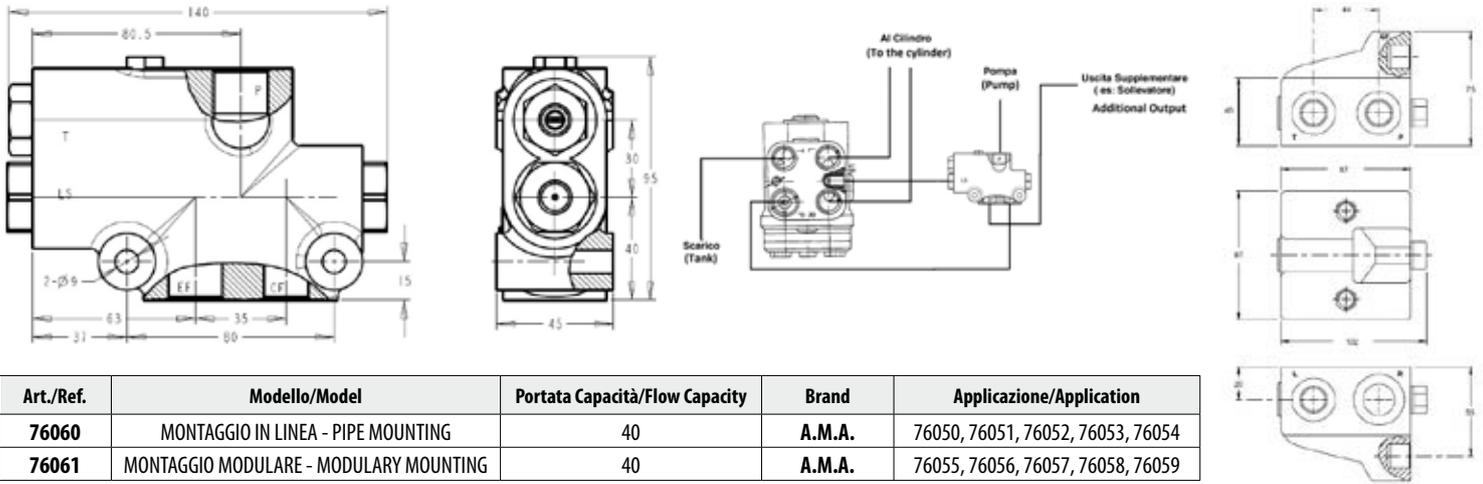
VALVOLE PRIORITARIE PER IDROGUIDE TIPO LS
CLAPET POUR HYDROGUIDE
PRIORITY VALVE FOR LS HYDRAULIC STEERING
MENGENTEILER
VALVULA PRIORITARIA PARA IDROGUIDA LS

Art./Ref.	Modello/Model	Portata Capacità/Flow Capacity	Brand	Applicazione/Application
76060	MONTAGGIO IN LINEA - PIPE MOUNTING	40	A.M.A.	76050, 76051, 76052, 76053, 76054
76061	MONTAGGIO MODULARE - MODULARY MOUNTING	40	A.M.A.	76055, 76056, 76057, 76058, 76059

SERBATOIO OLIO PER IDROGUIDE
RESERVOIR POUR ORBITROLS
OIL TANK FOR HYDRAULIC STEERING
ÖL TANK FÜR HYDROLENKUNGEN
DEPÓSITO DE ACEITE PARA IDROGUIDA



Art./Ref.	Descrizione/Description	Modello/Model	Brand	Rif. Orig./Orig. Ref.
08105	SERBATOIO OLIO X IDROGUIDE ATT.DIRITTO	DIRITTO	-	-
08106	SERBATOIO OLIO X IDROGUIDE ATT.90°	DIRITTO/90°	LANDINI - FIAT - MASSEY FERGUSON - FORD	5111529, 5111529, 3530018M92, 3300424, 3300424M94, 3530018

APPO PER SERBATOIO
BOUCHON RESERVOIR
TANK CAP FOR
STOEPSSEL FUER OELTANK
TAPA DEPOSITO

Art./Ref.	Tipo/Type
89343	SERBATOIO/TANK 08105

COLONNETTE DI STERZATURA PER IDROGUIDE CON CONICITA' C/6 (1:20)
COLONNES DE DIRECTION CONICITE' C/6 (1:20)
HYDRAULIC STEERING COLUMN FOR STEERING UNIT WHIT TAPER C/6 (1:20)
LENKSAEULE FUER HYDROLENKUNGEN MIT KEGELFORM C/6 (1:20)
COLUMNNA DE DIRECCIÓN IDROGUIDA PARA PUESTA A PUNTO C/6 (1:20)

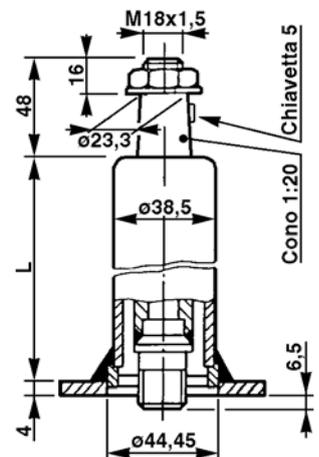
Art./Ref.	Lunghezza mm/Length mm
05206	80
12794	100
84706	124
05207	158
84707	199
84708	229
12795	249
84709	269
84710	299
84711	349
05217	389
84712	449
17499	519
84713	549
12796	602
84714	649
17500	669
84715	714
05218	758



1.2.8 Martinetti idraulici & cilindri

Hydraulic jacks & cylinders



Ricambi & accessori per macchine agricole

SPARE PARTS & ACCESSORIES FOR AGRICULTURAL MACHINE

Tutti gli articoli della presente sezione, prodotti da AMA SPA e/o da terzi per conto di AMA, sono adattabili ("non originali") alle marche indicate ai sensi di quanto previsto dal REG. CE n. 1400/2002. I diritti sui marchi citati appartengono ai legittimi proprietari ed il loro uso ha l'esclusiva finalità di consentire all'utilizzatore la comparazione dei diversi prodotti. All items of this section, manufactured by AMA SPA and/or any third party on behalf of AMA, are adaptable ("non-original") to the brands listed under the provisions of the REG. CE n. 1400/2002. The rights on the trademarks belong to their respective owners and their usage is only aimed to allow the user to compare different products.

CARATTERISTICHE TECNICHE PER CILINDRI

TECHNICAL SPECIFICATIONS FOR HYDRAULIC CYLINDER

Pressione esercizio: 180 bar
Pressione di picco: massimo 250 bar
Temperatura C° -25° + 80°
Barra Cromata: Acciaio UNI C45 SAE1045
Spessore cromatura: Cromo 25 Micron +/- 5
Tubo: acciaio St523 - DIN 2393 ISO H9
Testata di guida: ghisa UNI 5007 G25
Pistone: UNI 9SMn Pb28
Fondello: S235JR EN10027-1 (Fe360b)
Borchia Filettata: S235JR EN10027-1 (Fe360b)
Dado autobloccante: acciaio UNI 7473-7474
Guarnizioni: poliuretano
Boccole: S355JR EN10027-01 (Fe510b)

.....

Working pressure: 180 bar
Max pressure: 250 bar
Temperature: C° -25°+80°
Chrome rod: steel UNI C45 SAE1045
Thickness chroming: chrome 25 Micron +/- 5
Tube: steel St523 - DIN 2393 ISO H9
Head-bush: hydraulic cast iron UNI 5007 G25
Piston: UNI 9SMn Pb28
End-bottom: S235JR EN10027-1 (Fe360b)
Threaded bushing: S235JR EN10027-1 (Fe360b)
Locknut: steel UNI 7473-7474
Seal: polyurethane
Ferrules: S355JR EN10027-01 (Fe510b)

KIT GUARNIZIONI PER MARTINETTI IDRAULICI

KIT JOINTS POUR VERINS HYDRAULIQUES
SEAL KIT TELESCOPIC CYLINDERS
DISCHTUNGSSATZ FÜR TELESKOPZYLINDER
KIT JUNTAS PARA CILINDROS TELESCOPICOS
НАБОР УПЛОТНЕНИЙ ДЛЯ ГИДРОЦИЛИНДРОВ

Art./Ref.	Sfilate/Extension	Applicazione-impieghi/Application-use
58168	2	01411 - 01412 - 01415 - 01416
58169	3	01403 - 01414 - 01419 - 01420 - 01421 - 01422 - 01424 - 01425 - 01426 - 01427 - 01428
58170	4	01429 - 01432 - 01433 - 01434 - 01437 - 01440 - 01441 - 01442 - 01653
58171	5	01445 - 01446 - 01657
58172	3	01423 - 01652
58173	4	01655 - 01656

ATTACCO SUPERIORE SFERICO A RICAMBIO PER MARTINETTI

SPHERE DE RECHANGE POUR VERINS HYDRAULIQUES
UPPER BALL END FOR LIFTING JACKS
ERSATZ-OBERKUGEL VERSCHLUSS FÜR TELESKOPZYLINDER
BOLA DE ENGANCHE DE RECAMBIO
КРЕПЛЕНИЕ ВЕРХНЕЕ СФЕРИЧЕСКОЕ ЗАПАСНОЕ ДЛЯ ЦИЛИНДРОВ

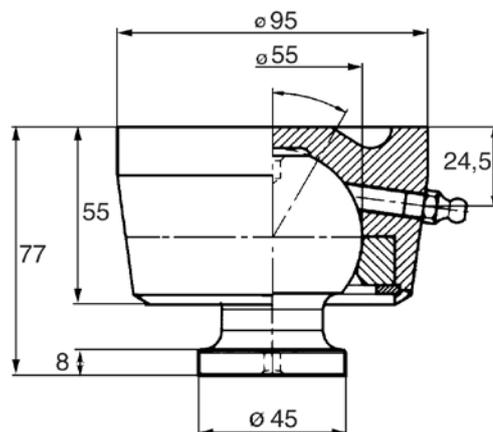

Art./Ref.
01400

SUPPORTI PER MARTINETTI IDRAULICI

SUPPORTS POUR VÉRINS HYDRAULIQUES
SUPPORTS FOR HYDRAULIC LIFTING JACKS
LAGER FÜR TELESKOPZILINDER
SOPORTE PARA MARTINETTI HIDRAÚLICO
ОПОРЫ ДЛЯ ГИДРОЦИЛИНДРОВ

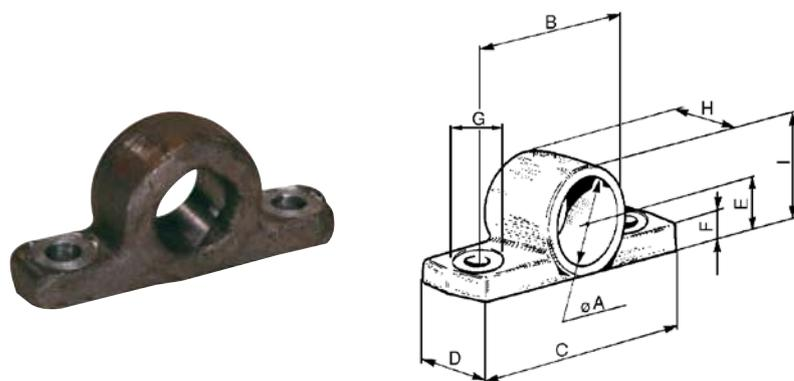

Art./Ref.	Misura A mm/ A size mm	Misura B mm/ B size mm	Misura C mm/ C size mm	Misura D mm/ D size mm	Misura E mm/ E size mm	Misura F mm/ F size mm	Misura G mm/ G size mm	Peso kg/ Weight kg
00822	35.50	95	130	45	30	12	13	0,60
00823	40.50	105	130	45	30	15	15	0.56
00824	50.50	105	140	45	33	15	15	0.69

GONDOLE TRILATERALI PER MARTINETTI

SUPPORT TRILATERAL POUR VÉRINS

THREE-LATE RESTS FOR LIFTING JACKS

WIEGE FÜR TELESKOPZILINDER

SOPORTE TRILATERAL PARA MARTINETTI

ГОНДОЛЫ ТРЁХСТОРОННИЕ ДЛЯ ГИДРОЦИЛИНДРОВ

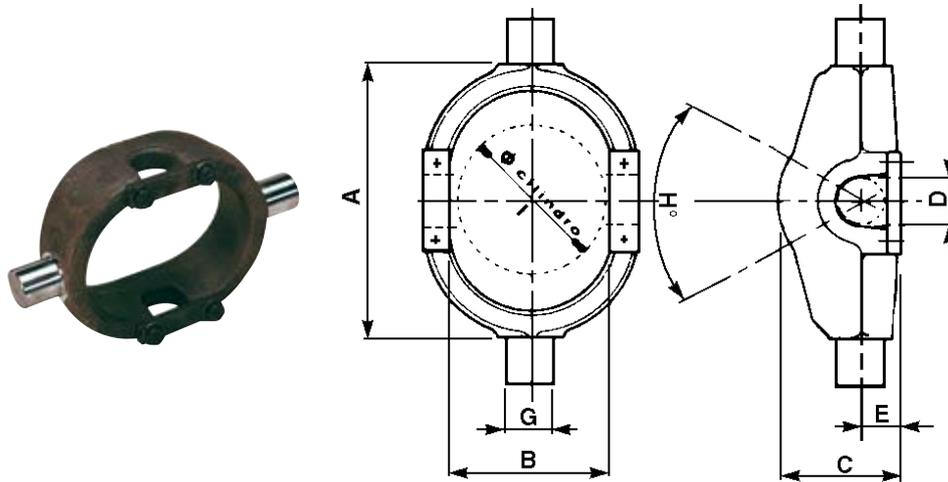

Art./Ref.	Misura A mm/ A size mm	Misura B mm/ B size mm	Misura C mm/ C size mm	Misura D mm/ D size mm	Misura E mm/ E size mm	Misura G mm/ G size mm	Misura H mm/ H size mm	Note/Notes
01009	200	120	77	35	25	35	65	ø CILINDRO / CYLINDER 95
01013	230	135	97	35	28	40	75	ø CILINDRO / CYLINDER 112
01016	230	155	107	40	31	40	65	ø CILINDRO / CYLINDER 124
01019	280	185	120	50	38	50	65	ø CILINDRO / CYLINDER 152

SERVOTIMONI IDRAULICI CON RITORNO A MOLLA

BEQUILLE HYDRAULIQUES

HYDRAULIC JACKS

HYDRAULISCHE STÜTZFÜSSE

SERVOMANDOS DE DIRECCIÓN HIDRÁULICOS - VUELA CON RESORTE

ДОМКРАТЫ ГИДРАВЛИЧЕСКИЕ С ПРУЖИННЫМ ОБРАТНЫМ ХОДОМ

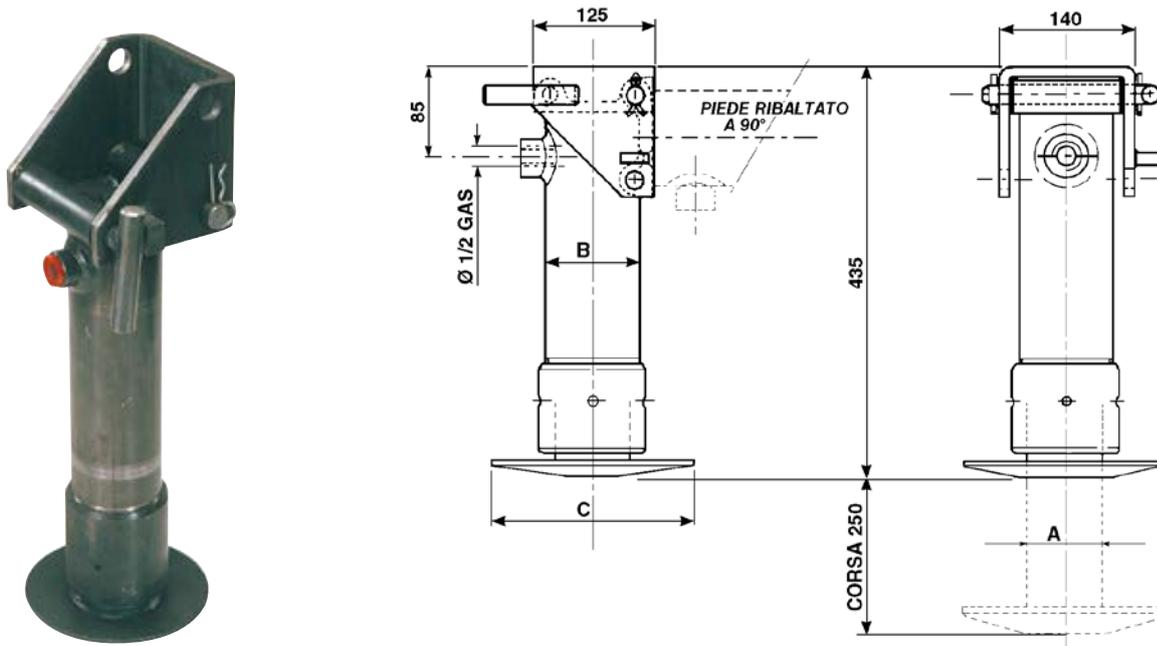

Art./Ref.	Carico verticale/Vertical load	Note/Notes	Misura A mm/A size mm	Misura B mm/B size mm	Misura C mm/C size mm	Misura D mm/D size mm
04622	100 bar - 3300kg / 150bar 4970kg	olio/oil 0,8 lt	65	80	160	CORSA 250
04623	100bar - 5670kg / 150bar - 8500kg	olio/oil 1,5 lt	85	100	215	CORSA 250

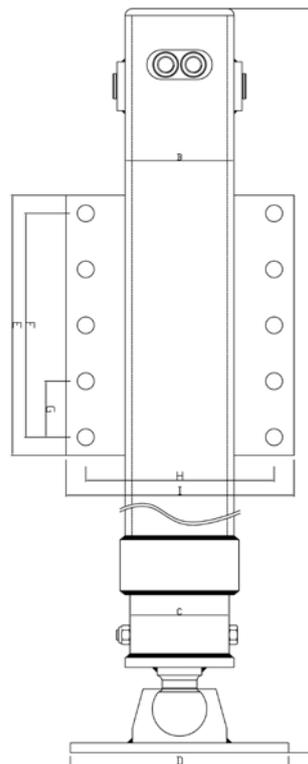
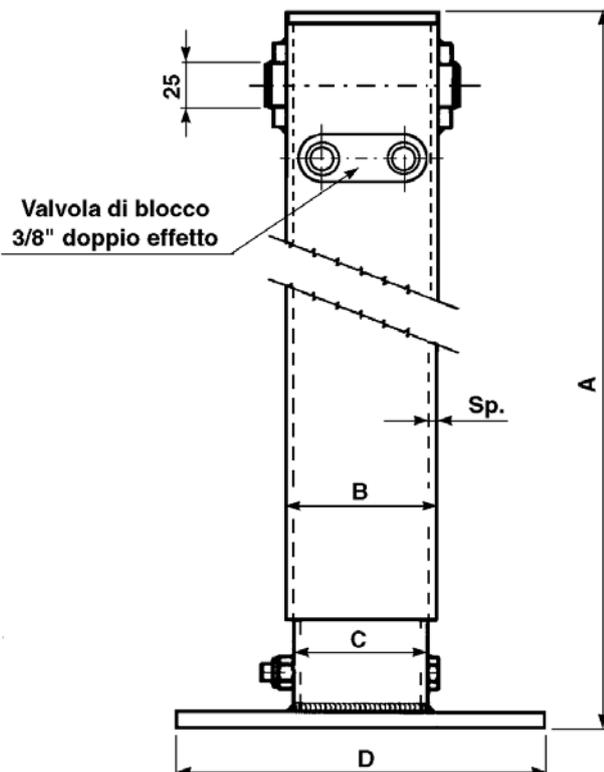
PIEDI IDRAULICI COMPLETI DI VALVOLA DI BLOCCO
BEQUILLE HYDRAULIQUES AVEC CLAPET DE BLOCAGE
HYDRAULIC PARKING JACK WITH BUILT-IN SAFETY VALVE
HYDRAULISCHE STÜTZFUSSE MIT SPERRBLOCKVENTIL
PIE HIDRÁULICO DE APOYO CON VÁLVULA DE BLOQUE
ГИДРАВЛИЧЕСКАЯ ОПОРА УКОМПЛЕКТОВАННАЯ БЛОКИРОВОЧНЫМ КЛАПАНОМ

Completi di valvola di blocco pilotata a doppio effetto da 3/8". Senza kit tubi. Grezzi.
Equipped with double acting check valve 3/8". Without hoses kit. Rough

Art./Ref.	Corsa/ Stroke	Carico verticale/Vertical load	Spessore mm/ Thickness mm	Misura A mm/A size mm	Misura B mm/B size mm	Misura C mm/C size mm	Misura D mm/D size mm	Misura E mm/E size mm	Misura F mm/F size mm	Misura G mm/G size mm	Misura H mm/H size mm	Misura I mm/I size mm	Misura L mm/L size mm
11016	350	a 100bar 1963kg, a 150bar 2945kg	4	635	90x90	80x80	220						
83824	400	a 100bar 1256kg, a 150bar 1884kg	4	675	80X80	70X70	350						
83825	400	a 100bar 1256kg, a 150bar 1884kg	4	762	80X80	70X70	350						
10454	400	a 100bar 1963kg, a 150bar 2945kg	4	675	100x100	90x90	180						
10455	500	a 100bar 1963kg, a 150bar 2945kg	4	775	100x100	90x90	180						
10456	400	a 100bar 2824kg, a 150bar 4241kg	4	675	100x100	90x90	180						
10457	500	a 100bar 2824kg, a 150bar 4241kg	4	775	100x100	90x90	180						
11021	500	a 100bar 3848kg, a 150bar 5772kg	4	785	110x110	100x100	250						
82796	700	a 100bar 3800, a 150bar 5700kg	4	985	110X110	100X100	250						
83817	400	a 100bar 1900kg, a 150bar 2900kg	4	762	100X100	90X90	180	265	228	57	190	230	
83818	500	a 100bar 1900kg, a 150bar 2900kg	4	862	100X100	90X90	180	265	228	57	190	230	
83819	400	a 100bar 2800kg, a 150bar 4200kg	4	762	100X100	90X90	180	265	228	57	190	230	
83821	500	a 100bar 2800kg, a 150bar 4200kg	4	862	100X100	90X90	180	265	228	57	190	230	
83822	500	a 100bar 3800kg, a 150bar 5700kg	4	872	110X110	100X100	250	265	228	57	190	230	
83823	700	a 100bar 3800kg, a 150bar 5700kg	4	1072	110X110	100X100	250	265	228	57	190	230	

CILINDRI A DOPPIO EFFETTO SENZA SUPPORTI D'ATTACCO

VERINS A DOUBLE EFFET SANS FIXATION

HYDRAULIC CYLINDERS DOUBLE ACTING WITHOUT ENDS

HYDRAULISCHE ZYLINDER DOPPELWIRKEND OHNE ANSCHLÜSSE

CILINDROS DOBLE EFECTO SIN FISACIONES

ЦИЛИНДРЫ ДВОЙНОГО ДЕЙСТВИЯ БЕЗ ОПОР КРЕПЛЕНИЯ

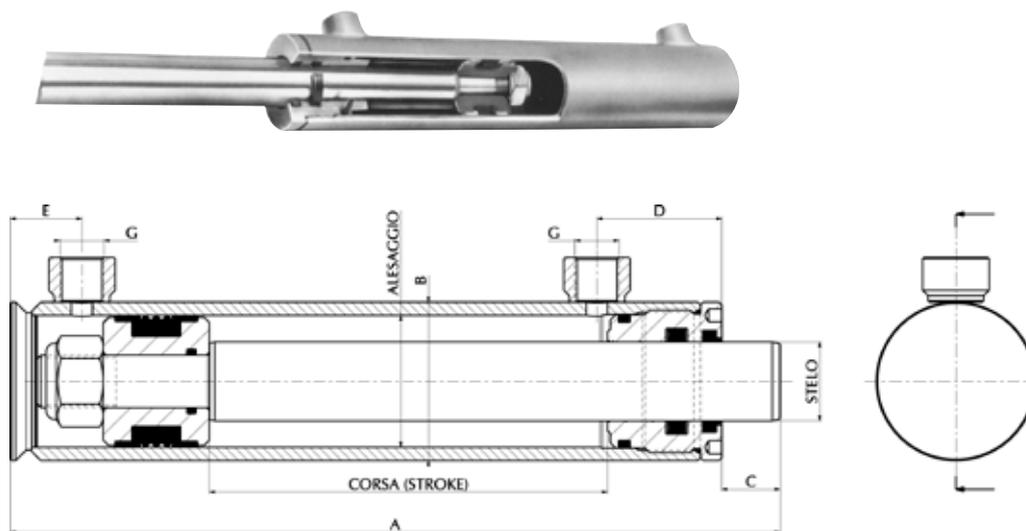

Art./Ref.	Alesaggio/ Bore	Stelo Ø/ Rod Ø	Corsa/ Stroke	Misura A mm/ A size mm	Misura B mm/ B size mm	Misura C mm/ C size mm	Misura D mm/ D size mm	Misura E mm/ E size mm	Misura G mm/ G size mm	Kit testa-kit pistone/ Rod guide kit-piston kit
82642	25	16	50	150	35	25	28	20	G 1/4"	0AS2516GC – 83876
82643	25	16	100	200	35	25	28	20	G 1/4"	0AS2516GC – 83876
82644	25	16	150	250	35	25	28	20	G 1/4"	0AS2516GC – 83876
82645	25	16	200	300	35	25	28	20	G 1/4"	0AS2516GC – 83876
82646	25	16	250	350	35	25	28	20	G 1/4"	0AS2516GC – 83876
82647	25	16	300	400	35	25	28	20	G 1/4"	0AS2516GC – 83876
81100	32	20	50	180	40	29	35	23	G 1/4"	0AS3220GC – 80723
81101	32	20	100	230	40	29	35	23	G 1/4"	0AS3220GC – 80723
81102	32	20	150	280	40	29	35	23	G 1/4"	0AS3220GC – 80723
81103	32	20	200	330	40	29	35	23	G 1/4"	0AS3220GC – 80723
81104	32	20	250	380	40	29	35	23	G 1/4"	0AS3220GC – 80723
81105	32	20	300	430	40	29	35	23	G 1/4"	0AS3220GC – 80723
81106	32	20	350	480	40	29	35	23	G 1/4"	0AS3220GC – 80723
81107	32	20	400	530	40	29	35	23	G 1/4"	0AS3220GC – 80723
81108	32	20	450	580	40	29	35	23	G 1/4"	0AS3220GC – 80723
81109	32	20	500	630	40	29	35	23	G 1/4"	0AS3220GC – 80723
81110	32	20	550	680	40	29	35	23	G 1/4"	0AS3220GC – 80723
81111	32	20	600	730	40	29	35	23	G 1/4"	0AS3220GC – 80723
81140	40	20	50	180	50	22	44	23	G 1/4"	0AS4020GC - 06130
37219	40	20	100	230	50	22	44	23	G 1/4"	0AS4020GC - 06130
17288	40	20	150	280	50	22	44	23	G 1/4"	0AS4020GC - 06130
17289	40	20	200	330	50	22	44	23	G 1/4"	0AS4020GC - 06130
17290	40	20	250	380	50	22	44	23	G 1/4"	0AS4020GC - 06130
17291	40	20	300	430	50	22	44	23	G 1/4"	0AS4020GC - 06130
17553	40	20	350	480	50	22	44	23	G 1/4"	0AS4020GC - 06130
17292	40	20	400	530	50	22	44	23	G 1/4"	0AS4020GC - 06130
17554	40	20	450	580	50	22	44	23	G 1/4"	0AS4020GC - 06130
81141	40	20	500	630	50	22	44	23	G 1/4"	0AS4020GC - 06130
81142	40	20	550	680	50	22	44	23	G 1/4"	0AS4020GC - 06130
81143	40	20	600	730	50	22	44	23	G 1/4"	0AS4020GC - 06130
81144	40	20	650	780	50	22	44	23	G 1/4"	0AS4020GC - 06130
81145	40	20	700	830	50	22	44	23	G 1/4"	0AS4020GC - 06130
81146	40	20	750	880	50	22	44	23	G 1/4"	0AS4020GC - 06130
81147	40	20	800	930	50	22	44	23	G 1/4"	0AS4020GC - 06130
81148	40	20	850	980	50	22	44	23	G 1/4"	0AS4020GC - 06130
81149	40	20	900	1030	50	22	44	23	G 1/4"	0AS4020GC - 06130

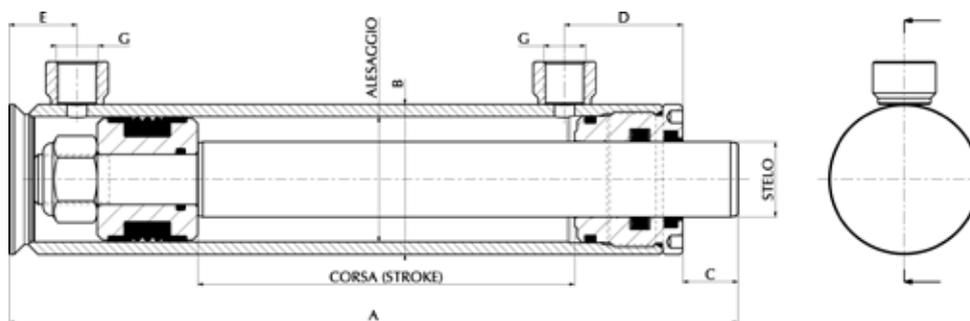

Art./Ref.	Alesaggio/ Bore	Stelo Ø/ Rod Ø	Corsa/ Stroke	Misura A mm/ A size mm	Misura B mm/ B size mm	Misura C mm/ C size mm	Misura D mm/ D size mm	Misura E mm/ E size mm	Misura G mm/ G size mm	Kit testa-kit pistone/ Rod guide kit-piston kit
81150	40	20	950	1080	50	22	44	23	G 1/4"	OAS4020GC - 06130
81151	40	20	1000	1130	50	22	44	23	G 1/4"	OAS4020GC - 06130
81152	40	25	50	180	50	22	44	23	G 1/4"	OAS4025GC - 06130
81153	40	25	100	230	50	22	44	23	G 1/4"	OAS4025GC - 06130
04928	40	25	150	280	50	22	44	23	G 1/4"	OAS4025GC - 06130
04929	40	25	200	330	50	22	44	23	G 1/4"	OAS4025GC - 06130
04930	40	25	250	380	50	22	44	23	G 1/4"	OAS4025GC - 06130
04931	40	25	300	430	50	22	44	23	G 1/4"	OAS4025GC - 06130
17555	40	25	350	480	50	22	44	23	G 1/4"	OAS4025GC - 06130
04932	40	25	400	530	50	22	44	23	G 1/4"	OAS4025GC - 06130
17556	40	25	450	580	50	22	44	23	G 1/4"	OAS4025GC - 06130
37220	40	25	500	630	50	22	44	23	G 1/4"	OAS4025GC - 06130
81154	40	25	550	680	50	22	44	23	G 1/4"	OAS4025GC - 06130
37221	40	25	600	730	50	22	44	23	G 1/4"	OAS4025GC - 06130
81155	40	25	650	780	50	22	44	23	G 1/4"	OAS4025GC - 06130
81156	40	25	700	830	50	22	44	23	G 1/4"	OAS4025GC - 06130
81157	40	25	750	880	50	22	44	23	G 1/4"	OAS4025GC - 06130
81158	40	25	800	930	50	22	44	23	G 1/4"	OAS4025GC - 06130
81159	40	25	850	980	50	22	44	23	G 1/4"	OAS4025GC - 06130
81160	40	25	900	1030	50	22	44	23	G 1/4"	OAS4025GC - 06130
81161	40	25	950	1080	50	22	44	23	G 1/4"	OAS4025GC - 06130
81162	40	25	1000	1130	50	22	44	23	G 1/4"	OAS4025GC - 06130
37222	50	25	100	240	60	22	47	27	G 3/8"	OAS5025GC - 06132
17293	50	25	150	290	60	22	47	27	G 3/8"	OAS5025GC - 06132
17294	50	25	200	340	60	22	47	27	G 3/8"	OAS5025GC - 06132
17295	50	25	250	390	60	22	47	27	G 3/8"	OAS5025GC - 06132
17296	50	25	300	440	60	22	47	27	G 3/8"	OAS5025GC - 06132
17557	50	25	350	490	60	22	47	27	G 3/8"	OAS5025GC - 06132
17297	50	25	400	540	60	22	47	27	G 3/8"	OAS5025GC - 06132
17558	50	25	450	590	60	22	47	27	G 3/8"	OAS5025GC - 06132
17298	50	25	500	640	60	22	47	27	G 3/8"	OAS5025GC - 06132
17559	50	25	550	690	60	22	47	27	G 3/8"	OAS5025GC - 06132
17299	50	25	600	740	60	22	47	27	G 3/8"	OAS5025GC - 06132
81163	50	25	650	790	60	22	47	27	G 3/8"	OAS5025GC - 06132
81164	50	25	700	840	60	22	47	27	G 3/8"	OAS5025GC - 06132
81165	50	25	750	890	60	22	47	27	G 3/8"	OAS5025GC - 06132
37223	50	25	800	940	60	22	47	27	G 3/8"	OAS5025GC - 06132
81166	50	25	850	990	60	22	47	27	G 3/8"	OAS5025GC - 06132
81167	50	25	900	1040	60	22	47	27	G 3/8"	OAS5025GC - 06132
81168	50	25	950	1090	60	22	47	27	G 3/8"	OAS5025GC - 06132
37224	50	25	1000	1140	60	22	47	27	G 3/8"	OAS5025GC - 06132
81169	50	30	100	240	60	22	47	27	G 3/8"	OAS5030GC - 06132
04933	50	30	150	290	60	22	47	27	G 3/8"	OAS5030GC - 06132
04934	50	30	200	340	60	22	47	27	G 3/8"	OAS5030GC - 06132
04935	50	30	250	390	60	22	47	27	G 3/8"	OAS5030GC - 06132
04936	50	30	300	440	60	22	47	27	G 3/8"	OAS5030GC - 06132
17560	50	30	350	490	60	22	47	27	G 3/8"	OAS5030GC - 06132
04937	50	30	400	540	60	22	47	27	G 3/8"	OAS5030GC - 06132

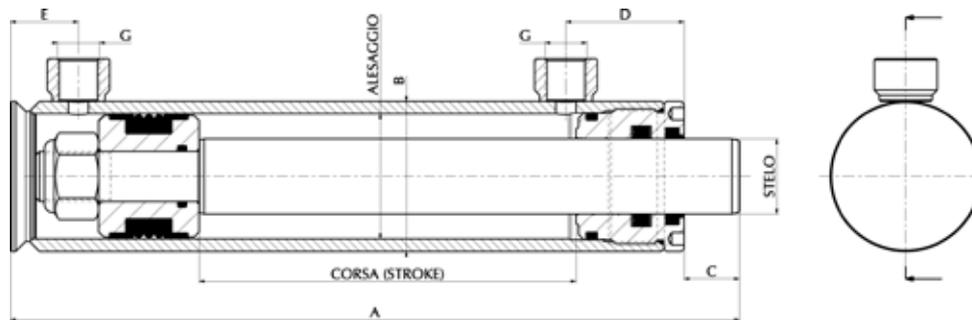

Art./Ref.	Alesaggio/ Bore	Stelo Ø/ Rod Ø	Corsa/ Stroke	Misura A mm/ A size mm	Misura B mm/ B size mm	Misura C mm/C size mm	Misura D mm/ D size mm	Misura E mm/ E size mm	Misura G mm/ G size mm	Kit testa-kit pistone/ Rod guide kit-piston kit
17561	50	30	450	590	60	22	47	27	G 3/8"	0AS5030GC - 06132
04938	50	30	500	640	60	22	47	27	G 3/8"	0AS5030GC - 06132
17562	50	30	550	690	60	22	47	27	G 3/8"	0AS5030GC - 06132
04939	50	30	600	740	60	22	47	27	G 3/8"	0AS5030GC - 06132
81195	50	30	650	790	60	22	47	27	G 3/8"	0AS5030GC - 06132
81196	50	30	700	840	60	22	47	27	G 3/8"	0AS5030GC - 06132
81197	50	30	750	890	60	22	47	27	G 3/8"	0AS5030GC - 06132
37225	50	30	800	940	60	22	47	27	G 3/8"	0AS5030GC - 06132
81198	50	30	850	990	60	22	47	27	G 3/8"	0AS5030GC - 06132
81199	50	30	900	1040	60	22	47	27	G 3/8"	0AS5030GC - 06132
81200	50	30	950	1090	60	22	47	27	G 3/8"	0AS5030GC - 06132
37226	50	30	1000	1140	60	22	47	27	G 3/8"	0AS5030GC - 06132
17563	60	30	100	260	70	23	54	25	G 3/8"	0AS6030GC - 06133
17300	60	30	150	310	70	23	54	25	G 3/8"	0AS6030GC - 06133
17301	60	30	200	360	70	23	54	25	G 3/8"	0AS6030GC - 06133
17302	60	30	250	410	70	23	54	25	G 3/8"	0AS6030GC - 06133
17303	60	30	300	460	70	23	54	25	G 3/8"	0AS6030GC - 06133
17564	60	30	350	510	70	23	54	25	G 3/8"	0AS6030GC - 06133
17304	60	30	400	560	70	23	54	25	G 3/8"	0AS6030GC - 06133
17565	60	30	450	610	70	23	54	25	G 3/8"	0AS6030GC - 06133
17305	60	30	500	660	70	23	54	25	G 3/8"	0AS6030GC - 06133
17566	60	30	550	710	70	23	54	25	G 3/8"	0AS6030GC - 06133
17306	60	30	600	760	70	23	54	25	G 3/8"	0AS6030GC - 06133
81201	60	30	650	810	70	23	54	25	G 3/8"	0AS6030GC - 06133
81202	60	30	700	860	70	23	54	25	G 3/8"	0AS6030GC - 06133
81203	60	30	750	910	70	23	54	25	G 3/8"	0AS6030GC - 06133
37227	60	30	800	960	70	23	54	25	G 3/8"	0AS6030GC - 06133
81204	60	30	850	1010	70	23	54	25	G 3/8"	0AS6030GC - 06133
81205	60	30	900	1060	70	23	54	25	G 3/8"	0AS6030GC - 06133
81206	60	30	950	1110	70	23	54	25	G 3/8"	0AS6030GC - 06133
37228	60	30	1000	1160	70	23	54	25	G 3/8"	0AS6030GC - 06133
17567	60	35	100	260	70	23	54	25	G 3/8"	0AS6035GC - 06133
17568	60	35	150	310	70	23	54	25	G 3/8"	0AS6035GC - 06133
17307	60	35	200	360	70	23	54	25	G 3/8"	0AS6035GC - 06133
17308	60	35	250	410	70	23	54	25	G 3/8"	0AS6035GC - 06133
17309	60	35	300	460	70	23	54	25	G 3/8"	0AS6035GC - 06133
17569	60	35	350	510	70	23	54	25	G 3/8"	0AS6035GC - 06133
17310	60	35	400	560	70	23	54	25	G 3/8"	0AS6035GC - 06133
17570	60	35	450	610	70	23	54	25	G 3/8"	0AS6035GC - 06133
17311	60	35	500	660	70	23	54	25	G 3/8"	0AS6035GC - 06133
17571	60	35	550	710	70	23	54	25	G 3/8"	0AS6035GC - 06133
17312	60	35	600	760	70	23	54	25	G 3/8"	0AS6035GC - 06133
81560	60	35	650	810	70	23	54	25	G 3/8"	0AS6035GC - 06133
80809	60	35	700	860	70	23	54	25	G 3/8"	0AS6035GC - 06133
81561	60	35	750	910	70	23	54	25	G 3/8"	0AS6035GC - 06133
37229	60	35	800	960	70	23	54	25	G 3/8"	0AS6035GC - 06133
81562	60	35	850	1010	70	23	54	25	G 3/8"	0AS6035GC - 06133
0603590	60	35	900	1060	70	23	54	25	G 3/8"	0AS6035GC - 06133

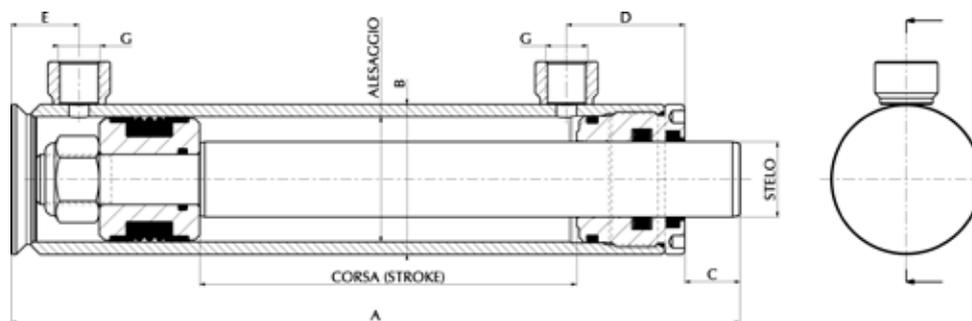

Art./Ref.	Alesaggio/ Bore	Stelo Ø/ Rod Ø	Corsa/ Stroke	Misura A mm/ A size mm	Misura B mm/ B size mm	Misura C mm/ C size mm	Misura D mm/ D size mm	Misura E mm/ E size mm	Misura G mm/ G size mm	Kit testa-kit pistone/ Rod guide kit-piston kit
81563	60	35	950	1110	70	23	54	25	G 3/8"	OAS6035GC - 06133
37230	60	35	1000	1160	70	23	54	25	G 3/8"	OAS6035GC - 06133
81564	60	40	100	260	70	23	54	25	G 3/8"	OAS6040GC - 18219
81565	60	40	150	310	70	23	54	25	G 3/8"	OAS6040GC - 18219
37241	60	40	200	360	70	23	54	25	G 3/8"	OAS6040GC - 18219
37242	60	40	250	410	70	23	54	25	G 3/8"	OAS6040GC - 18219
37243	60	40	300	460	70	23	54	25	G 3/8"	OAS6040GC - 18219
37244	60	40	350	510	70	23	54	25	G 3/8"	OAS6040GC - 18219
37245	60	40	400	560	70	23	54	25	G 3/8"	OAS6040GC - 18219
37246	60	40	450	610	70	23	54	25	G 3/8"	OAS6040GC - 18219
37247	60	40	500	660	70	23	54	25	G 3/8"	OAS6040GC - 18219
81566	60	40	550	710	70	23	54	25	G 3/8"	OAS6040GC - 18219
37249	60	40	600	760	70	23	54	25	G 3/8"	OAS6040GC - 18219
81567	60	40	650	810	70	23	54	25	G 3/8"	OAS6040GC - 18219
0604070	60	40	700	860	70	23	54	25	G 3/8"	OAS6040GC - 18219
81568	60	40	750	910	70	23	54	25	G 3/8"	OAS6040GC - 18219
37250	60	40	800	960	70	23	54	25	G 3/8"	OAS6040GC - 18219
81569	60	40	850	1010	70	23	54	25	G 3/8"	OAS6040GC - 18219
0604090	60	40	900	1060	70	23	54	25	G 3/8"	OAS6040GC - 18219
81570	60	40	950	1110	70	23	54	25	G 3/8"	OAS6040GC - 18219
37251	60	40	1000	1160	70	23	54	25	G 3/8"	OAS6040GC - 18219
37231	70	35	100	260	80	23	54	25	G 3/8"	OAS7035GC - 06135
37232	70	35	150	310	80	23	54	25	G 3/8"	OAS7035GC - 06135
17319	70	35	200	360	80	23	54	25	G 3/8"	OAS7035GC - 06135
17320	70	35	250	410	80	23	54	25	G 3/8"	OAS7035GC - 06135
17321	70	35	300	460	80	23	54	25	G 3/8"	OAS7035GC - 06135
17572	70	35	350	510	80	23	54	25	G 3/8"	OAS7035GC - 06135
17322	70	35	400	560	80	23	54	25	G 3/8"	OAS7035GC - 06135
17573	70	35	450	610	80	23	54	25	G 3/8"	OAS7035GC - 06135
17323	70	35	500	660	80	23	54	25	G 3/8"	OAS7035GC - 06135
17574	70	35	550	710	80	23	54	25	G 3/8"	OAS7035GC - 06135
17324	70	35	600	760	80	23	54	25	G 3/8"	OAS7035GC - 06135
0703565	70	35	650	810	80	23	54	25	G 3/8"	OAS7035GC - 06135
0703570	70	35	700	860	80	23	54	25	G 3/8"	OAS7035GC - 06135
0703575	70	35	750	910	80	23	54	25	G 3/8"	OAS7035GC - 06135
37233	70	35	800	960	80	23	54	25	G 3/8"	OAS7035GC - 06135
81584	70	35	850	1010	80	23	54	25	G 3/8"	OAS7035GC - 06135
0703590	70	35	900	1060	80	23	54	25	G 3/8"	OAS7035GC - 06135
81585	70	35	950	1110	80	23	54	25	G 3/8"	OAS7035GC - 06135
37234	70	35	1000	1160	80	23	54	25	G 3/8"	OAS7035GC - 06135
070410	70	40	100	260	80	23	54	25	G 3/8"	OAS7040GC - 06135
070415	70	40	150	310	80	23	54	25	G 3/8"	OAS7040GC - 06135
04946	70	40	200	360	80	23	54	25	G 3/8"	OAS7040GC - 06135
04947	70	40	250	410	80	23	54	25	G 3/8"	OAS7040GC - 06135
04948	70	40	300	460	80	23	54	25	G 3/8"	OAS7040GC - 06135
17575	70	40	350	510	80	23	54	25	G 3/8"	OAS7040GC - 06135
04949	70	40	400	560	80	23	54	25	G 3/8"	OAS7040GC - 06135
17576	70	40	450	610	80	23	54	25	G 3/8"	OAS7040GC - 06135

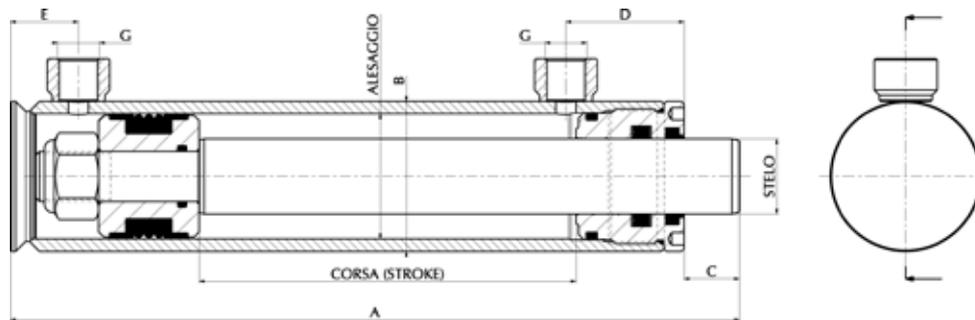

Art./Ref.	Alesaggio/ Bore	Stelo Ø/ Rod Ø	Corsa/ Stroke	Misura A mm/ A size mm	Misura B mm/ B size mm	Misura C mm/C size mm	Misura D mm/ D size mm	Misura E mm/ E size mm	Misura G mm/ G size mm	Kit testa-kit pistone/ Rod guide kit-piston kit
04950	70	40	500	660	80	23	54	25	G 3/8"	0AS7040GC - 06135
17577	70	40	550	710	80	23	54	25	G 3/8"	0AS7040GC - 06135
04951	70	40	600	760	80	23	54	25	G 3/8"	0AS7040GC - 06135
81586	70	40	650	810	80	23	54	25	G 3/8"	0AS7040GC - 06135
0704070	70	40	700	860	80	23	54	25	G 3/8"	0AS7040GC - 06135
0407075	70	40	750	910	80	23	54	25	G 3/8"	0AS7040GC - 06135
37235	70	40	800	960	80	23	54	25	G 3/8"	0AS7040GC - 06135
81587	70	40	850	1010	80	23	54	25	G 3/8"	0AS7040GC - 06135
81588	70	40	900	1060	80	23	54	25	G 3/8"	0AS7040GC - 06135
81589	70	40	950	1110	80	23	54	25	G 3/8"	0AS7040GC - 06135
37236	70	40	1000	1160	80	23	54	25	G 3/8"	0AS7040GC - 06135
81590	80	40	100	275	95	25	64	25	G 3/8"	0AS8040GC - 06136
0804015	80	40	150	325	95	25	64	25	G 3/8"	0AS8040GC - 06136
04952	80	40	200	375	95	25	64	25	G 3/8"	0AS8040GC - 06136
04953	80	40	250	425	95	25	64	25	G 3/8"	0AS8040GC - 06136
04954	80	40	300	475	95	25	64	25	G 3/8"	0AS8040GC - 06136
0804035	80	40	350	525	95	25	64	25	G 3/8"	0AS8040GC - 06136
04955	80	40	400	575	95	25	64	25	G 3/8"	0AS8040GC - 06136
0804045	80	40	450	625	95	25	64	25	G 3/8"	0AS8040GC - 06136
04956	80	40	500	675	95	25	64	25	G 3/8"	0AS8040GC - 06136
81591	80	40	550	725	95	25	64	25	G 3/8"	0AS8040GC - 06136
04957	80	40	600	775	95	25	64	25	G 3/8"	0AS8040GC - 06136
81592	80	40	650	825	95	25	64	25	G 3/8"	0AS8040GC - 06136
0804070	80	40	700	875	95	25	64	25	G 3/8"	0AS8040GC - 06136
81593	80	40	750	925	95	25	64	25	G 3/8"	0AS8040GC - 06136
37237	80	40	800	975	95	25	64	25	G 3/8"	0AS8040GC - 06136
81594	80	40	850	1025	95	25	64	25	G 3/8"	0AS8040GC - 06136
81595	80	40	900	1075	95	25	64	25	G 3/8"	0AS8040GC - 06136
81596	80	40	950	1125	95	25	64	25	G 3/8"	0AS8040GC - 06136
37238	80	40	1000	1175	95	25	64	25	G 3/8"	0AS8040GC - 06136
81597	80	50	100	275	95	25	64	25	G 3/8"	0AS8050GC - 06136
81598	80	50	150	325	95	25	64	25	G 3/8"	0AS8050GC - 06136
17325	80	50	200	375	95	25	64	25	G 3/8"	0AS8050GC - 06136
17326	80	50	250	425	95	25	64	25	G 3/8"	0AS8050GC - 06136
17327	80	50	300	475	95	25	64	25	G 3/8"	0AS8050GC - 06136
0805035	80	50	350	525	95	25	64	25	G 3/8"	0AS8050GC - 06136
17328	80	50	400	575	95	25	64	25	G 3/8"	0AS8050GC - 06136
0805045	80	50	450	625	95	25	64	25	G 3/8"	0AS8050GC - 06136
17329	80	50	500	675	95	25	64	25	G 3/8"	0AS8050GC - 06136
0805055	80	50	550	725	95	25	64	25	G 3/8"	0AS8050GC - 06136
17330	80	50	600	775	95	25	64	25	G 3/8"	0AS8050GC - 06136
81599	80	50	650	825	95	25	64	25	G 3/8"	0AS8050GC - 06136
0805070	80	50	700	875	95	25	64	25	G 3/8"	0AS8050GC - 06136
0805075	80	50	750	925	95	25	64	25	G 3/8"	0AS8050GC - 06136
37239	80	50	800	975	95	25	64	25	G 3/8"	0AS8050GC - 06136
81600	80	50	850	1025	95	25	64	25	G 3/8"	0AS8050GC - 06136
0805090	80	50	900	1075	95	25	64	25	G 3/8"	0AS8050GC - 06136
81601	80	50	950	1125	95	25	64	25	G 3/8"	0AS8050GC - 06136

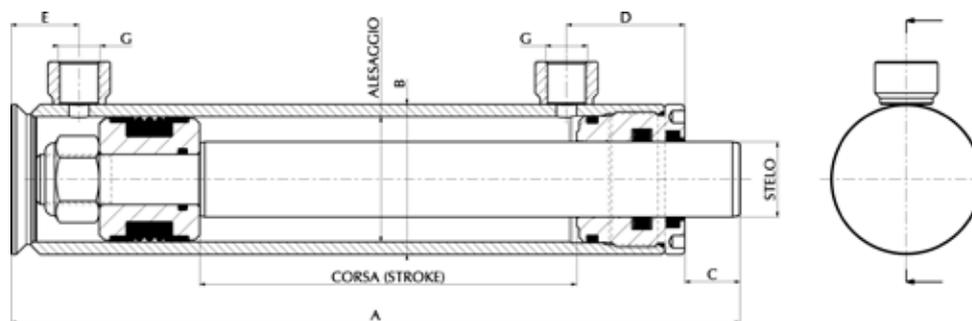

Art./Ref.	Alesaggio/ Bore	Stelo Ø/ Rod Ø	Corsa/ Stroke	Misura A mm/ A size mm	Misura B mm/ B size mm	Misura C mm/ C size mm	Misura D mm/ D size mm	Misura E mm/ E size mm	Misura G mm/ G size mm	Kit testa-kit pistone/ Rod guide kit-piston kit
37240	80	50	1000	1175	95	25	64	25	G 3/8"	OAS8050GC - 06136
81615	90	45	100	290	105	37	64	28	G 3/8"	OAS9045GC - 06137
81616	90	45	150	340	105	37	64	28	G 3/8"	OAS9045GC - 06137
81617	90	45	200	390	105	37	64	28	G 3/8"	OAS9045GC - 06137
0904525	90	45	250	440	105	37	64	28	G 3/8"	OAS9045GC - 06137
0904530	90	45	300	490	105	37	64	28	G 3/8"	OAS9045GC - 06137
81618	90	45	350	540	105	37	64	28	G 3/8"	OAS9045GC - 06137
81619	90	45	400	590	105	37	64	28	G 3/8"	OAS9045GC - 06137
81620	90	45	450	640	105	37	64	28	G 3/8"	OAS9045GC - 06137
81621	90	45	500	690	105	37	64	28	G 3/8"	OAS9045GC - 06137
81622	90	45	550	740	105	37	64	28	G 3/8"	OAS9045GC - 06137
81623	90	45	600	790	105	37	64	28	G 3/8"	OAS9045GC - 06137
81624	90	45	650	840	105	37	64	28	G 3/8"	OAS9045GC - 06137
81625	90	45	700	890	105	37	64	28	G 3/8"	OAS9045GC - 06137
81626	90	45	750	940	105	37	64	28	G 3/8"	OAS9045GC - 06137
81627	90	45	800	990	105	37	64	28	G 3/8"	OAS9045GC - 06137
81628	90	45	850	1040	105	37	64	28	G 3/8"	OAS9045GC - 06137
81629	90	45	900	1090	105	37	64	28	G 3/8"	OAS9045GC - 06137
81630	90	45	950	1140	105	37	64	28	G 3/8"	OAS9045GC - 06137
81631	90	45	1000	1190	105	37	64	28	G 3/8"	OAS9045GC - 06137
0905010	90	50	100	290	105	37	64	28	G 3/8"	OAS9050GC - 06137
81632	90	50	150	340	105	37	64	28	G 3/8"	OAS9050GC - 06137
81633	90	50	200	390	105	37	64	28	G 3/8"	OAS9050GC - 06137
0905025	90	50	250	440	105	37	64	28	G 3/8"	OAS9050GC - 06137
0905030	90	50	300	490	105	37	64	28	G 3/8"	OAS9050GC - 06137
81634	90	50	350	540	105	37	64	28	G 3/8"	OAS9050GC - 06137
0905040	90	50	400	590	105	37	64	28	G 3/8"	OAS9050GC - 06137
81635	90	50	450	640	105	37	64	28	G 3/8"	OAS9050GC - 06137
0905050	90	50	500	690	105	37	64	28	G 3/8"	OAS9050GC - 06137
81636	90	50	550	740	105	37	64	28	G 3/8"	OAS9050GC - 06137
0905060	90	50	600	790	105	37	64	28	G 3/8"	OAS9050GC - 06137
81637	90	50	650	840	105	37	64	28	G 3/8"	OAS9050GC - 06137
81638	90	50	700	890	105	37	64	28	G 3/8"	OAS9050GC - 06137
0905075	90	50	750	940	105	37	64	28	G 3/8"	OAS9050GC - 06137
81639	90	50	800	990	105	37	64	28	G 3/8"	OAS9050GC - 06137
81640	90	50	850	1040	105	37	64	28	G 3/8"	OAS9050GC - 06137
81641	90	50	900	1090	105	37	64	28	G 3/8"	OAS9050GC - 06137
81642	90	50	950	1140	105	37	64	28	G 3/8"	OAS9050GC - 06137
09050100	90	50	1000	1190	105	37	64	28	G 3/8"	OAS9050GC - 06137
81643	100	50	100	290	115	25	66	28	G 3/8"	OAS150GCA - 06138
81644	100	50	150	340	115	25	66	28	G 3/8"	OAS150GCA - 06138
0A15020	100	50	200	390	115	25	66	28	G 3/8"	OAS150GCA - 06138
17341	100	50	250	440	115	25	66	28	G 3/8"	OAS150GCA - 06138
17342	100	50	300	490	115	25	66	28	G 3/8"	OAS150GCA - 06138
81645	100	50	350	540	115	25	66	28	G 3/8"	OAS150GCA - 06138
17343	100	50	400	590	115	25	66	28	G 3/8"	OAS150GCA - 06138
81646	100	50	450	640	115	25	66	28	G 3/8"	OAS150GCA - 06138
17344	100	50	500	690	115	25	66	28	G 3/8"	OAS150GCA - 06138

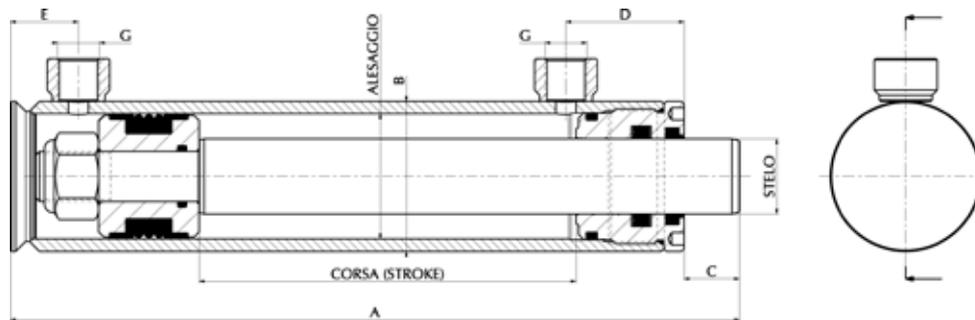

Art./Ref.	Alesaggio/ Bore	Stelo Ø/ Rod Ø	Corsa/ Stroke	Misura A mm/ A size mm	Misura B mm/ B size mm	Misura C mm/C size mm	Misura D mm/ D size mm	Misura E mm/ E size mm	Misura G mm/ G size mm	Kit testa-kit pistone/ Rod guide kit-piston kit
81647	100	50	550	740	115	25	66	28	G 3/8"	0AS150GCA - 06138
17345	100	50	600	790	115	25	66	28	G 3/8"	0AS150GCA - 06138
81648	100	50	650	840	115	25	66	28	G 3/8"	0AS150GCA - 06138
0A15070	100	50	700	890	115	25	66	28	G 3/8"	0AS150GCA - 06138
81649	100	50	750	940	115	25	66	28	G 3/8"	0AS150GCA - 06138
81650	100	50	800	990	115	25	66	28	G 3/8"	0AS150GCA - 06138
81651	100	50	850	1040	115	25	66	28	G 3/8"	0AS150GCA - 06138
81652	100	50	900	1090	115	25	66	28	G 3/8"	0AS150GCA - 06138
81653	100	50	950	1140	115	25	66	28	G 3/8"	0AS150GCA - 06138
0A150100	100	50	1000	1190	115	25	66	28	G 3/8"	0AS150GCA - 06138
81654	100	60	100	290	115	25	66	28	G 3/8"	0AS160GCA - 06138
0A16015	100	60	150	340	115	25	66	28	G 3/8"	0AS160GCA - 06138
81655	100	60	200	390	115	25	66	28	G 3/8"	0AS160GCA - 06138
17346	100	60	250	440	115	25	66	28	G 3/8"	0AS160GCA - 06138
17347	100	60	300	490	115	25	66	28	G 3/8"	0AS160GCA - 06138
81656	100	60	350	540	115	25	66	28	G 3/8"	0AS160GCA - 06138
17348	100	60	400	590	115	25	66	28	G 3/8"	0AS160GCA - 06138
81657	100	60	450	640	115	25	66	28	G 3/8"	0AS160GCA - 06138
17349	100	60	500	690	115	25	66	28	G 3/8"	0AS160GCA - 06138
81658	100	60	550	740	115	25	66	28	G 3/8"	0AS160GCA - 06138
17350	100	60	600	790	115	25	66	28	G 3/8"	0AS160GCA - 06138
81659	100	60	650	840	115	25	66	28	G 3/8"	0AS160GCA - 06138
0A16070	100	60	700	890	115	25	66	28	G 3/8"	0AS160GCA - 06138
81660	100	60	750	940	115	25	66	28	G 3/8"	0AS160GCA - 06138
0A16080	100	60	800	990	115	25	66	28	G 3/8"	0AS160GCA - 06138
81661	100	60	850	1040	115	25	66	28	G 3/8"	0AS160GCA - 06138
80792	100	60	900	1090	115	25	66	28	G 3/8"	0AS160GCA - 06138
81663	100	60	950	1140	115	25	66	28	G 3/8"	0AS160GCA - 06138
81664	100	60	1000	1190	115	25	66	28	G 3/8"	0AS160GCA - 06138

CILINDRI STANDARD A DOPPIO EFFETTO

VERINS STANDARD A DOUBLE EFFECT

STANDARD HYDRAULIC CYLINDERS DOUBLE ACTING

HYDRAULISCHE DOPPELWIRKENDE STANDARTZYLINDER

CILINDROS DOBLE EFECTO

ЦИЛИНДРЫ СТАНДАРТНЫЕ С ДВОЙНЫМ ЭФФЕКТОМ

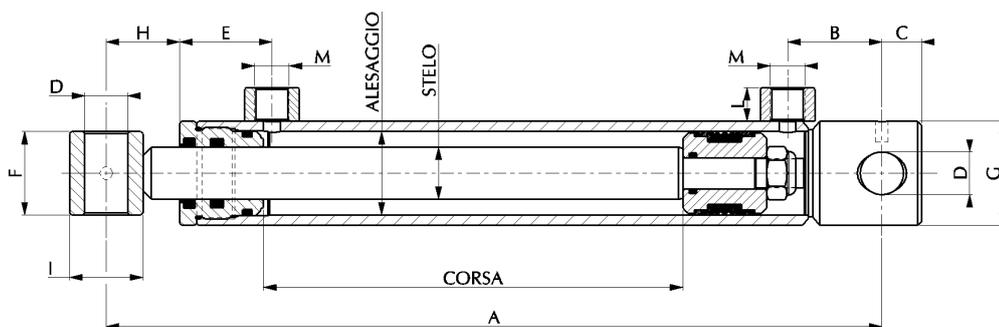

Art./Ref.	Alesaggio/ Bore	Stelo Ø/ Rod Ø	Corsa/ Stroke	A mm	B mm	C mm	D mm	E mm	F mm	G mm	H mm	I mm	L mm	M mm	Peso kg/ Weight kg	Kit testa-kit pistone/ Rod guide kit-piston kit
OCDE322005	32	20	50	205	33	17	16	44	35	40	32	30	16	1/4"	1,9	0AS3220GC-80723
OCDE322010	32	20	100	255	33	17	16	44	35	40	32	30	16	1/4"	2,2	0AS3220GC-80723
OCDE322015	32	20	150	305	33	17	16	44	35	40	32	30	16	1/4"	2,6	0AS3220GC-80723
OCDE322020	32	20	200	355	33	17	16	44	35	40	32	30	16	1/4"	2,9	0AS3220GC-80723
OCDE322030	32	20	300	455	33	17	16	44	35	40	32	30	16	1/4"	3,6	0AS3220GC-80723
OCDE402510	40	25	100	270	45	19	20,5	44	40	50	35	35	17	3/8"	3,7	0AS4025GC-06130
OCDE402520	40	25	200	370	45	19	20,5	44	40	50	35	35	17	3/8"	4,5	0AS4025GC-06130
OCDE402530	40	25	300	470	45	19	20,5	44	40	50	35	35	17	3/8"	5,5	0AS4025GC-06130
OCDE402540	40	25	400	570	45	19	20,5	44	40	50	35	35	17	3/8"	6,5	0AS4025GC-06130
OCDE402550	40	25	500	670	45	19	20,5	44	40	50	35	35	17	3/8"	7,5	0AS4025GC-06130
OCDE503010	50	30	100	300	58	25	25,5	47	45	60	47	40	17	3/8"	4	0AS5030GC-06132
OCDE503020	50	30	200	400	58	25	25,5	47	45	60	47	40	17	3/8"	5	0AS5030GC-06132
OCDE503030	50	30	300	500	58	25	25,5	47	45	60	47	40	17	3/8"	6	0AS5030GC-06132
OCDE503040	50	30	400	600	58	25	25,5	47	45	60	47	40	17	3/8"	8	0AS5030GC-06132
OCDE503050	50	30	500	700	58	25	25,5	47	45	60	47	40	17	3/8"	10	0AS5030GC-06132
OCDE503060	50	30	600	800	58	25	25,5	47	45	60	47	40	17	3/8"	12	0AS5030GC-06132
OCDE503070	50	30	700	900	58	25	25,5	47	45	60	47	40	17	3/8"	14	0AS5030GC-06132
OCDE603010	60	30	100	300	58	25	25,5	54	45	70	30	40	17	3/8"	6	0AS6030GC-06133
OCDE603020	60	30	200	400	58	25	25,5	54	45	70	30	40	17	3/8"	7	0AS6030GC-06133
OCDE603030	60	30	300	500	58	25	25,5	54	45	70	30	40	17	3/8"	9	0AS6030GC-06133
OCDE603040	60	30	400	600	58	25	25,5	54	45	70	30	40	17	3/8"	11	0AS6030GC-06133
OCDE603050	60	30	500	700	58	25	25,5	54	45	70	30	40	17	3/8"	13	0AS6030GC-06133
OCDE603060	60	30	600	800	58	25	25,5	54	45	70	30	40	17	3/8"	15	0AS6030GC-06133
OCDE603070	60	30	700	900	58	25	25,5	54	45	70	30	40	17	3/8"	17	0AS6030GC-06133
OCDE704020	70	40	200	410	58	25	30,5	65	55	80	40	50	15	3/8"	11	0AS7040GC-06135
OCDE704030	70	40	300	510	58	25	30,5	65	55	80	40	50	15	3/8"	13	0AS7040GC-06135
OCDE704040	70	40	400	610	58	25	30,5	65	55	80	40	50	15	3/8"	15	0AS7040GC-06135
OCDE704050	70	40	500	710	58	25	30,5	65	55	80	40	50	15	3/8"	17	0AS7040GC-06135
OCDE704060	70	40	600	810	58	25	30,5	65	55	80	40	50	15	3/8"	19	0AS7040GC-06135
OCDE704070	70	40	700	910	58	25	30,5	65	55	80	40	50	15	3/8"	21	0AS7040GC-06135
OCDE804020	80	40	200	410	58	25	30,5	64	55	90	55	50	17	3/8"	13	0AS8040GC-06136
OCDE804030	80	40	300	510	58	25	30,5	64	55	90	55	50	17	3/8"	15	0AS8040GC-06136
OCDE804040	80	40	400	610	58	25	30,5	64	55	90	55	50	17	3/8"	18	0AS8040GC-06136
OCDE804050	80	40	500	710	58	25	30,5	64	55	90	55	50	17	3/8"	21	0AS8040GC-06136
OCDE804070	80	40	700	910	58	25	30,5	64	55	90	55	50	17	3/8"	27	0AS8040GC-06136
OCDEA15030	100	50	300	525	55	34	30,5	64	70	115	66	65	17	3/8"	27	0AS150GCA-06138
OCDEA15040	100	50	400	625	55	34	30,5	64	70	115	66	65	17	3/8"	30	0AS150GCA-06138
OCDEA15050	100	50	500	725	55	34	30,5	64	70	115	66	65	17	3/8"	35	0AS150GCA-06138
OCDEA15070	100	50	700	925	55	34	30,5	64	70	115	66	65	17	3/8"	40	0AS150GCA-06138
OCDEA15090	100	50	900	1125	55	34	30,5	64	70	115	66	65	17	3/8"	42	0AS150GCA-06138

CILINDRI A DOPPIO EFFETTO CON SNODI

VERINS A DOUBLE EFFET AVEC ROTULES

HYDRAULIC CYLINDERS DOUBLE ACTING WITH JOINTS

HYDRAULISCHE ZYLINDER DOPPELWIRKEND MIT GELENKE

CILINDROS DOBLE EFECTO CON COJINETES

ЦИЛИНДРЫ ДВОЙНОГО ДЕЙСТВИЯ С ШАРНИРОМ

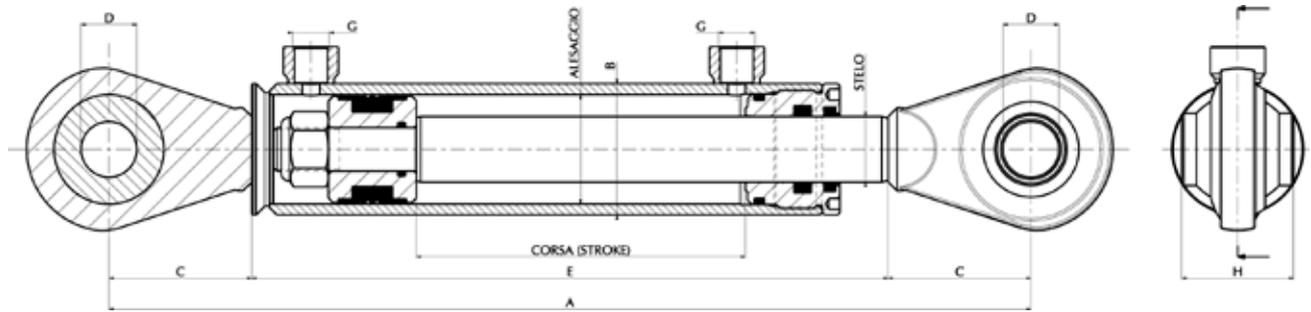

Art./Ref.	Alesaggio/ Bore	Stelo Ø/ Rod Ø	Corsa/ Stroke	Misura A mm/ A size mm	Misura B mm/ B size mm	Misura C mm/ C size mm	Misura D mm/ D size mm	Misura E mm/ E size mm	Misura G mm/ G size mm	Misura H mm/ H size mm	Kit testa-kit pistone/ Rod guide kit-piston kit
81291	40	20	50	270	50	45	16	180	G 1/4"	20	0AS4020GC - 06130
81292	40	20	100	320	50	45	16	230	G 1/4"	20	0AS4020GC - 06130
81293	40	20	150	370	50	45	16	280	G 1/4"	20	0AS4020GC - 06130
81294	40	20	200	420	50	45	16	330	G 1/4"	20	0AS4020GC - 06130
81295	40	20	250	470	50	45	16	380	G 1/4"	20	0AS4020GC - 06130
81296	40	20	300	520	50	45	16	430	G 1/4"	20	0AS4020GC - 06130
81297	40	20	350	570	50	45	16	480	G 1/4"	20	0AS4020GC - 06130
81298	40	20	400	620	50	45	16	530	G 1/4"	20	0AS4020GC - 06130
81299	40	20	450	670	50	45	16	580	G 1/4"	20	0AS4020GC - 06130
81300	40	20	500	720	50	45	16	630	G 1/4"	20	0AS4020GC - 06130
81301	40	20	550	770	50	45	16	680	G 1/4"	20	0AS4020GC - 06130
81302	40	20	600	820	50	45	16	730	G 1/4"	20	0AS4020GC - 06130
81303	40	20	650	870	50	45	16	780	G 1/4"	20	0AS4020GC - 06130
81304	40	20	700	920	50	45	16	830	G 1/4"	20	0AS4020GC - 06130
81305	40	20	750	970	50	45	16	880	G 1/4"	20	0AS4020GC - 06130
81306	40	20	800	1020	50	45	16	930	G 1/4"	20	0AS4020GC - 06130
81307	40	20	850	1070	50	45	16	980	G 1/4"	20	0AS4020GC - 06130
81308	40	20	900	1120	50	45	16	1030	G 1/4"	20	0AS4020GC - 06130
81309	40	20	950	1170	50	45	16	1080	G 1/4"	20	0AS4020GC - 06130
81310	40	20	1000	1220	50	45	16	1130	G 1/4"	20	0AS4020GC - 06130
81311	40	25	50	270	50	45	16	180	G 1/4"	20	0AS4025GC - 06130
81312	40	25	100	320	50	45	16	230	G 1/4"	20	0AS4025GC - 06130
81313	40	25	150	370	50	45	16	280	G 1/4"	20	0AS4025GC - 06130
81314	40	25	200	420	50	45	16	330	G 1/4"	20	0AS4025GC - 06130
81315	40	25	250	470	50	45	16	380	G 1/4"	20	0AS4025GC - 06130
81316	40	25	300	520	50	45	16	430	G 1/4"	20	0AS4025GC - 06130
81317	40	25	350	570	50	45	16	480	G 1/4"	20	0AS4025GC - 06130
81318	40	25	400	620	50	45	16	530	G 1/4"	20	0AS4025GC - 06130
81319	40	25	450	670	50	45	16	580	G 1/4"	20	0AS4025GC - 06130
81320	40	25	500	720	50	45	16	630	G 1/4"	20	0AS4025GC - 06130
81321	40	25	550	770	50	45	16	680	G 1/4"	20	0AS4025GC - 06130
81322	40	25	600	820	50	45	16	730	G 1/4"	20	0AS4025GC - 06130
81323	40	25	650	870	50	45	16	780	G 1/4"	20	0AS4025GC - 06130
81324	40	25	700	920	50	45	16	830	G 1/4"	20	0AS4025GC - 06130
81325	40	25	750	970	50	45	16	880	G 1/4"	20	0AS4025GC - 06130
81326	40	25	800	1020	50	45	16	930	G 1/4"	20	0AS4025GC - 06130
81327	40	25	850	1070	50	45	16	980	G 1/4"	20	0AS4025GC - 06130
81328	40	25	900	1120	50	45	16	1030	G 1/4"	20	0AS4025GC - 06130
81329	40	25	950	1170	50	45	16	1080	G 1/4"	20	0AS4025GC - 06130
81330	40	25	1000	1220	50	45	16	1130	G 1/4"	20	0AS4025GC - 06130
81331	50	25	100	360	60	60	20	240	G 3/8"	44	0AS5025GC - 06132
81332	50	25	150	410	60	60	20	290	G 3/8"	44	0AS5025GC - 06132

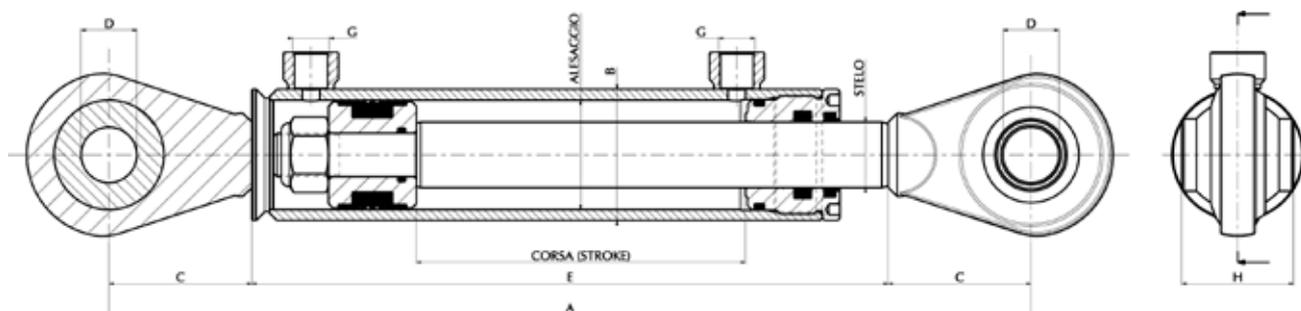

Art./Ref.	Alesaggio/ Bore	Stelo Ø/ Rod Ø	Corsa/ Stroke	Misura A mm/ A size mm	Misura B mm/ B size mm	Misura C mm/ C size mm	Misura D mm/ D size mm	Misura E mm/ E size mm	Misura G mm/ G size mm	Misura H mm/ H size mm	Kit testa-kit pistone/ Rod guide kit-piston kit
81333	50	25	200	460	60	60	20	340	G 3/8"	44	OAS5025GC- 06132
81334	50	25	250	510	60	60	20	390	G 3/8"	44	OAS5025GC- 06132
81335	50	25	300	560	60	60	20	440	G 3/8"	44	OAS5025GC- 06132
81336	50	25	350	610	60	60	20	490	G 3/8"	44	OAS5025GC- 06132
81337	50	25	400	660	60	60	20	540	G 3/8"	44	OAS5025GC- 06132
81338	50	25	450	710	60	60	20	590	G 3/8"	44	OAS5025GC- 06132
81339	50	25	500	760	60	60	20	640	G 3/8"	44	OAS5025GC- 06132
81340	50	25	550	810	60	60	20	690	G 3/8"	44	OAS5025GC- 06132
81341	50	25	600	860	60	60	20	740	G 3/8"	44	OAS5025GC- 06132
81342	50	25	650	910	60	60	20	790	G 3/8"	44	OAS5025GC- 06132
81343	50	25	700	960	60	60	20	840	G 3/8"	44	OAS5025GC- 06132
81344	50	25	750	1010	60	60	20	890	G 3/8"	44	OAS5025GC- 06132
81345	50	25	800	1060	60	60	20	940	G 3/8"	44	OAS5025GC- 06132
81346	50	25	850	1110	60	60	20	990	G 3/8"	44	OAS5025GC- 06132
81347	50	25	900	1160	60	60	20	1040	G 3/8"	44	OAS5025GC- 06132
81348	50	25	950	1210	60	60	20	1090	G 3/8"	44	OAS5025GC- 06132
81349	50	25	1000	1260	60	60	20	1140	G 3/8"	44	OAS5025GC- 06132
81350	50	30	100	370	60	65	25,4	240	G 3/8"	51	OAS5030GC- 06132
81351	50	30	150	420	60	65	25,4	290	G 3/8"	51	OAS5030GC- 06132
81352	50	30	200	470	60	65	25,4	340	G 3/8"	51	OAS5030GC- 06132
81353	50	30	250	520	60	65	25,4	390	G 3/8"	51	OAS5030GC- 06132
81354	50	30	300	570	60	65	25,4	440	G 3/8"	51	OAS5030GC- 06132
81355	50	30	350	620	60	65	25,4	490	G 3/8"	51	OAS5030GC- 06132
81356	50	30	400	670	60	65	25,4	540	G 3/8"	51	OAS5030GC- 06132
81357	50	30	450	720	60	65	25,4	590	G 3/8"	51	OAS5030GC- 06132
81358	50	30	500	770	60	65	25,4	640	G 3/8"	51	OAS5030GC- 06132
81359	50	30	550	820	60	65	25,4	690	G 3/8"	51	OAS5030GC- 06132
81360	50	30	600	870	60	65	25,4	740	G 3/8"	51	OAS5030GC- 06132
81361	50	30	650	920	60	65	25,4	790	G 3/8"	51	OAS5030GC- 06132
81362	50	30	700	970	60	65	25,4	840	G 3/8"	51	OAS5030GC- 06132
81363	50	30	750	1020	60	65	25,4	890	G 3/8"	51	OAS5030GC- 06132
81364	50	30	800	1070	60	65	25,4	940	G 3/8"	51	OAS5030GC- 06132
81365	50	30	850	1120	60	65	25,4	990	G 3/8"	51	OAS5030GC- 06132
81366	50	30	900	1170	60	65	25,4	1040	G 3/8"	51	OAS5030GC- 06132
81367	50	30	950	1220	60	65	25,4	1090	G 3/8"	51	OAS5030GC- 06132
81368	50	30	1000	1270	60	65	25,4	1140	G 3/8"	51	OAS5030GC- 06132
81369	60	30	100	390	70	65	25,4	260	G 3/8"	51	OAS6030GC- 06133
81370	60	30	150	440	70	65	25,4	310	G 3/8"	51	OAS6030GC- 06133
81371	60	30	200	490	70	65	25,4	360	G 3/8"	51	OAS6030GC- 06133
81372	60	30	250	540	70	65	25,4	410	G 3/8"	51	OAS6030GC- 06133
81373	60	30	300	590	70	65	25,4	460	G 3/8"	51	OAS6030GC- 06133
81374	60	30	350	640	70	65	25,4	510	G 3/8"	51	OAS6030GC- 06133
81375	60	30	400	690	70	65	25,4	560	G 3/8"	51	OAS6030GC- 06133
81376	60	30	450	740	70	65	25,4	610	G 3/8"	51	OAS6030GC- 06133
81377	60	30	500	790	70	65	25,4	660	G 3/8"	51	OAS6030GC- 06133
81378	60	30	550	840	70	65	25,4	710	G 3/8"	51	OAS6030GC- 06133
81379	60	30	600	890	70	65	25,4	760	G 3/8"	51	OAS6030GC- 06133
81380	60	30	650	940	70	65	25,4	810	G 3/8"	51	OAS6030GC- 06133

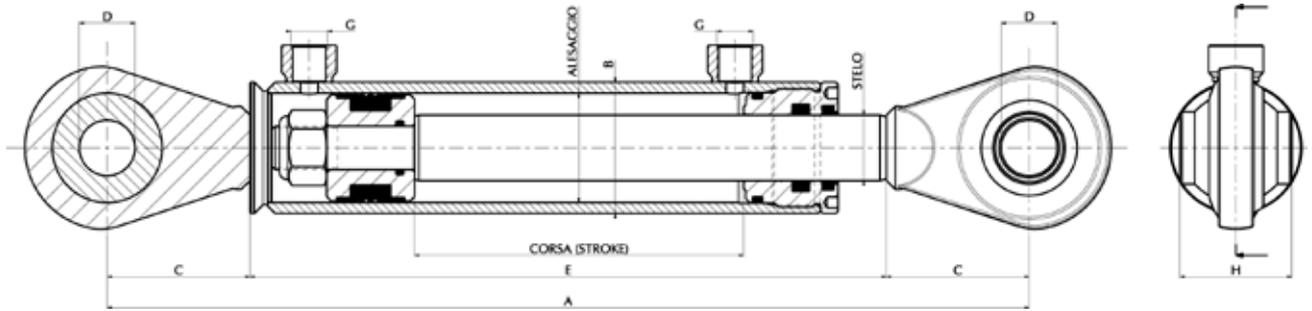

Art./Ref.	Alesaggio/ Bore	Stelo Ø/ Rod Ø	Corsa/ Stroke	Misura A mm/ A size mm	Misura B mm/ B size mm	Misura C mm/ C size mm	Misura D mm/ D size mm	Misura E mm/ E size mm	Misura G mm/ G size mm	Misura H mm/ H size mm	Kit testa-kit pistone/ Rod guide kit-piston kit
81381	60	30	700	990	70	65	25,4	860	G 3/8"	51	0AS6030GC- 06133
81382	60	30	750	1040	70	65	25,4	910	G 3/8"	51	0AS6030GC- 06133
81383	60	30	800	1090	70	65	25,4	960	G 3/8"	51	0AS6030GC- 06133
81384	60	30	850	1140	70	65	25,4	1010	G 3/8"	51	0AS6030GC- 06133
81385	60	30	900	1190	70	65	25,4	1060	G 3/8"	51	0AS6030GC- 06133
81386	60	30	950	1240	70	65	25,4	1110	G 3/8"	51	0AS6030GC- 06133
81387	60	30	1000	1290	70	65	25,4	1160	G 3/8"	51	0AS6030GC- 06133
81388	60	35	100	390	70	65	25,4	260	G 3/8"	51	0AS6035GC- 06133
81389	60	35	150	440	70	65	25,4	310	G 3/8"	51	0AS6035GC- 06133
81390	60	35	200	490	70	65	25,4	360	G 3/8"	51	0AS6035GC- 06133
81391	60	35	250	540	70	65	25,4	410	G 3/8"	51	0AS6035GC- 06133
81392	60	35	300	590	70	65	25,4	460	G 3/8"	51	0AS6035GC- 06133
81393	60	35	350	640	70	65	25,4	510	G 3/8"	51	0AS6035GC- 06133
81394	60	35	400	690	70	65	25,4	560	G 3/8"	51	0AS6035GC- 06133
81395	60	35	450	740	70	65	25,4	610	G 3/8"	51	0AS6035GC- 06133
81396	60	35	500	790	70	65	25,4	660	G 3/8"	51	0AS6035GC- 06133
81397	60	35	550	840	70	65	25,4	710	G 3/8"	51	0AS6035GC- 06133
81398	60	35	600	890	70	65	25,4	760	G 3/8"	51	0AS6035GC- 06133
81399	60	35	650	940	70	65	25,4	810	G 3/8"	51	0AS6035GC- 06133
81400	60	35	700	990	70	65	25,4	860	G 3/8"	51	0AS6035GC- 06133
81401	60	35	750	1040	70	65	25,4	910	G 3/8"	51	0AS6035GC- 06133
81402	60	35	800	1090	70	65	25,4	960	G 3/8"	51	0AS6035GC- 06133
81403	60	35	850	1140	70	65	25,4	1010	G 3/8"	51	0AS6035GC- 06133
81404	60	35	900	1190	70	65	25,4	1060	G 3/8"	51	0AS6035GC- 06133
81405	60	35	950	1240	70	65	25,4	1110	G 3/8"	51	0AS6035GC- 06133
81406	60	35	1000	1290	70	65	25,4	1160	G 3/8"	51	0AS6035GC- 06133
81407	60	40	100	390	70	65	25,4	260	G 3/8"	51	0AS6040GC - 18219
81408	60	40	150	440	70	65	25,4	310	G 3/8"	51	0AS6040GC - 18219
81409	60	40	200	490	70	65	25,4	360	G 3/8"	51	0AS6040GC - 18219
81410	60	40	250	540	70	65	25,4	410	G 3/8"	51	0AS6040GC - 18219
81411	60	40	300	590	70	65	25,4	460	G 3/8"	51	0AS6040GC - 18219
81412	60	40	350	640	70	65	25,4	510	G 3/8"	51	0AS6040GC - 18219
81413	60	40	400	690	70	65	25,4	560	G 3/8"	51	0AS6040GC - 18219
81414	60	40	450	740	70	65	25,4	610	G 3/8"	51	0AS6040GC - 18219
81415	60	40	500	790	70	65	25,4	660	G 3/8"	51	0AS6040GC - 18219
81416	60	40	550	840	70	65	25,4	710	G 3/8"	51	0AS6040GC - 18219
81417	60	40	600	890	70	65	25,4	760	G 3/8"	51	0AS6040GC - 18219
81418	60	40	650	940	70	65	25,4	810	G 3/8"	51	0AS6040GC - 18219
81419	60	40	700	990	70	65	25,4	860	G 3/8"	51	0AS6040GC - 18219
81420	60	40	750	1040	70	65	25,4	910	G 3/8"	51	0AS6040GC - 18219
81421	60	40	800	1090	70	65	25,4	960	G 3/8"	51	0AS6040GC - 18219
81422	60	40	850	1140	70	65	25,4	1010	G 3/8"	51	0AS6040GC - 18219
81423	60	40	900	1190	70	65	25,4	1060	G 3/8"	51	0AS6040GC - 18219
81424	60	40	950	1240	70	65	25,4	1110	G 3/8"	51	0AS6040GC - 18219
81425	60	40	1000	1290	70	65	25,4	1160	G 3/8"	51	0AS6040GC - 18219
81445	70	35	100	390	80	65	25,4	260	G 3/8"	51	0AS7035GC - 06135
81446	70	35	150	440	80	65	25,4	310	G 3/8"	51	0AS7035GC - 06135
81447	70	35	200	490	80	65	25,4	360	G 3/8"	51	0AS7035GC - 06135
81448	70	35	250	540	80	65	25,4	410	G 3/8"	51	0AS7035GC - 06135

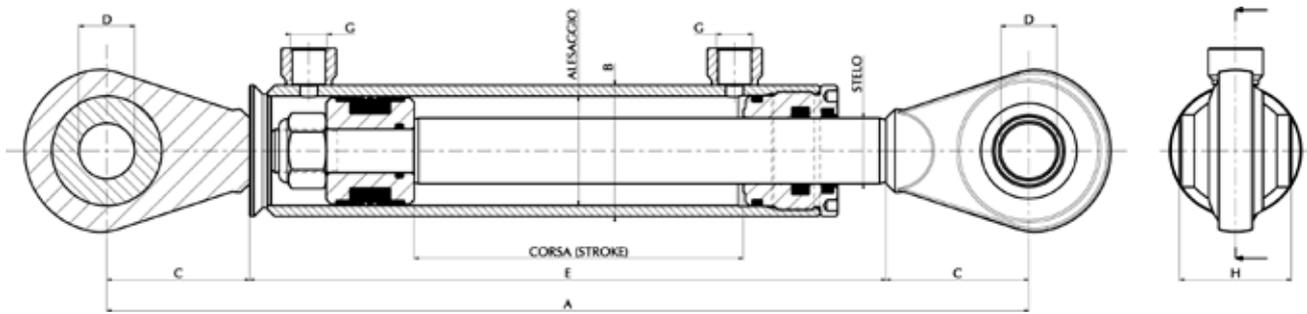

Art./Ref.	Alesaggio/ Bore	Stelo Ø/ Rod Ø	Corsa/ Stroke	Misura A mm/ A size mm	Misura B mm/ B size mm	Misura C mm/ C size mm	Misura D mm/ D size mm	Misura E mm/ E size mm	Misura G mm/ G size mm	Misura H mm/ H size mm	Kit testa-kit pistone/ Rod guide kit-piston kit
81449	70	35	300	590	80	65	25,4	460	G 3/8"	51	0AS7035GC - 06135
81450	70	35	350	640	80	65	25,4	510	G 3/8"	51	0AS7035GC - 06135
81451	70	35	400	690	80	65	25,4	560	G 3/8"	51	0AS7035GC - 06135
81452	70	35	450	740	80	65	25,4	610	G 3/8"	51	0AS7035GC - 06135
81453	70	35	500	790	80	65	25,4	660	G 3/8"	51	0AS7035GC - 06135
81454	70	35	550	840	80	65	25,4	710	G 3/8"	51	0AS7035GC - 06135
81455	70	35	600	890	80	65	25,4	760	G 3/8"	51	0AS7035GC - 06135
81456	70	35	650	940	80	65	25,4	810	G 3/8"	51	0AS7035GC - 06135
81457	70	35	700	990	80	65	25,4	860	G 3/8"	51	0AS7035GC - 06135
81458	70	35	750	1040	80	65	25,4	910	G 3/8"	51	0AS7035GC - 06135
81459	70	35	800	1090	80	65	25,4	960	G 3/8"	51	0AS7035GC - 06135
81460	70	35	850	1140	80	65	25,4	1010	G 3/8"	51	0AS7035GC - 06135
81461	70	35	900	1190	80	65	25,4	1060	G 3/8"	51	0AS7035GC - 06135
81462	70	35	950	1240	80	65	25,4	1110	G 3/8"	51	0AS7035GC - 06135
81463	70	35	1000	1290	80	65	25,4	1160	G 3/8"	51	0AS7035GC - 06135
81464	70	40	100	390	80	65	25,4	260	G 3/8"	51	0AS7040GC - 06135
81465	70	40	150	440	80	65	25,4	310	G 3/8"	51	0AS7040GC - 06135
81466	70	40	200	490	80	65	25,4	360	G 3/8"	51	0AS7040GC - 06135
81467	70	40	250	540	80	65	25,4	410	G 3/8"	51	0AS7040GC - 06135
81468	70	40	300	590	80	65	25,4	460	G 3/8"	51	0AS7040GC - 06135
81469	70	40	350	640	80	65	25,4	510	G 3/8"	51	0AS7040GC - 06135
81470	70	40	400	690	80	65	25,4	560	G 3/8"	51	0AS7040GC - 06135
81471	70	40	450	740	80	65	25,4	610	G 3/8"	51	0AS7040GC - 06135
81472	70	40	500	790	80	65	25,4	660	G 3/8"	51	0AS7040GC - 06135
81473	70	40	550	840	80	65	25,4	710	G 3/8"	51	0AS7040GC - 06135
81474	70	40	600	890	80	65	25,4	760	G 3/8"	51	0AS7040GC - 06135
81475	70	40	650	940	80	65	25,4	810	G 3/8"	51	0AS7040GC - 06135
81476	70	40	700	990	80	65	25,4	860	G 3/8"	51	0AS7040GC - 06135
81477	70	40	750	1040	80	65	25,4	910	G 3/8"	51	0AS7040GC - 06135
81478	70	40	800	1090	80	65	25,4	960	G 3/8"	51	0AS7040GC - 06135
81479	70	40	850	1140	80	65	25,4	1010	G 3/8"	51	0AS7040GC - 06135
81480	70	40	900	1190	80	65	25,4	1060	G 3/8"	51	0AS7040GC - 06135
81481	70	40	950	1240	80	65	25,4	1110	G 3/8"	51	0AS7040GC - 06135
81482	70	40	1000	1290	80	65	25,4	1160	G 3/8"	51	0AS7040GC - 06135
81483	80	40	100	405	95	65	30	275	G 3/8"	55	0AS8040GC - 06136
81484	80	40	150	455	95	65	30	325	G 3/8"	55	0AS8040GC - 06136
81485	80	40	200	505	95	65	30	375	G 3/8"	55	0AS8040GC - 06136
81486	80	40	250	555	95	65	30	425	G 3/8"	55	0AS8040GC - 06136
81487	80	40	300	605	95	65	30	475	G 3/8"	55	0AS8040GC - 06136
81488	80	40	350	655	95	65	30	525	G 3/8"	55	0AS8040GC - 06136
81489	80	40	400	705	95	65	30	575	G 3/8"	55	0AS8040GC - 06136
81490	80	40	450	755	95	65	30	625	G 3/8"	55	0AS8040GC - 06136
81491	80	40	500	805	95	65	30	675	G 3/8"	55	0AS8040GC - 06136
81492	80	40	550	855	95	65	30	725	G 3/8"	55	0AS8040GC - 06136
81493	80	40	600	905	95	65	30	775	G 3/8"	55	0AS8040GC - 06136
81494	80	40	650	955	95	65	30	825	G 3/8"	55	0AS8040GC - 06136
81495	80	40	700	1005	95	65	30	875	G 3/8"	55	0AS8040GC - 06136
81496	80	40	750	1055	95	65	30	925	G 3/8"	55	0AS8040GC - 06136
81497	80	40	800	1105	95	65	30	975	G 3/8"	55	0AS8040GC - 06136

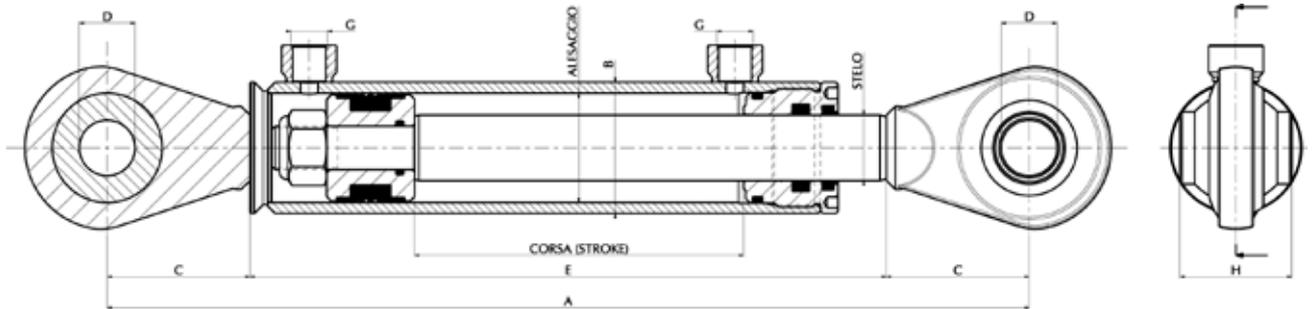

Art./Ref.	Alesaggio/ Bore	Stelo Ø/ Rod Ø	Corsa/ Stroke	Misura A mm/ A size mm	Misura B mm/ B size mm	Misura C mm/ C size mm	Misura D mm/ D size mm	Misura E mm/ E size mm	Misura G mm/ G size mm	Misura H mm/ H size mm	Kit testa-kit pistone/ Rod guide kit-piston kit
81498	80	40	850	1155	95	65	30	1025	G 3/8"	55	OAS8040GC - 06136
81499	80	40	900	1205	95	65	30	1075	G 3/8"	55	OAS8040GC - 06136
81500	80	40	950	1255	95	65	30	1125	G 3/8"	55	OAS8040GC - 06136
81501	80	40	1000	1305	95	65	30	1175	G 3/8"	55	OAS8040GC - 06136
81502	80	50	100	405	95	65	30	275	G 3/8"	55	OAS8050GC - 06136
81503	80	50	150	455	95	65	30	325	G 3/8"	55	OAS8050GC - 06136
81504	80	50	200	505	95	65	30	375	G 3/8"	55	OAS8050GC - 06136
81505	80	50	250	555	95	65	30	425	G 3/8"	55	OAS8050GC - 06136
81506	80	50	300	605	95	65	30	475	G 3/8"	55	OAS8050GC - 06136
81507	80	50	350	655	95	65	30	525	G 3/8"	55	OAS8050GC - 06136
81508	80	50	400	705	95	65	30	575	G 3/8"	55	OAS8050GC - 06136
81509	80	50	450	755	95	65	30	625	G 3/8"	55	OAS8050GC - 06136
81510	80	50	500	805	95	65	30	675	G 3/8"	55	OAS8050GC - 06136
81511	80	50	550	855	95	65	30	725	G 3/8"	55	OAS8050GC - 06136
81512	80	50	600	905	95	65	30	775	G 3/8"	55	OAS8050GC - 06136
81513	80	50	650	955	95	65	30	825	G 3/8"	55	OAS8050GC - 06136
81514	80	50	700	1005	95	65	30	875	G 3/8"	55	OAS8050GC - 06136
81515	80	50	750	1055	95	65	30	925	G 3/8"	55	OAS8050GC - 06136
81516	80	50	800	1105	95	65	30	975	G 3/8"	55	OAS8050GC - 06136
81517	80	50	850	1155	95	65	30	1025	G 3/8"	55	OAS8050GC - 06136
81518	80	50	900	1205	95	65	30	1075	G 3/8"	55	OAS8050GC - 06136
81519	80	50	950	1255	95	65	30	1125	G 3/8"	55	OAS8050GC - 06136
81520	80	50	1000	1305	95	65	30	1175	G 3/8"	55	OAS8050GC - 06136
81521	100	50	100	460	115	85	40	290	G 3/8"	75	OAS150GCA - 06138
81522	100	50	150	510	115	85	40	340	G 3/8"	75	OAS150GCA - 06138
81523	100	50	200	560	115	85	40	390	G 3/8"	75	OAS150GCA - 06138
81524	100	50	250	610	115	85	40	440	G 3/8"	75	OAS150GCA - 06138
81525	100	50	300	660	115	85	40	490	G 3/8"	75	OAS150GCA - 06138
81526	100	50	350	710	115	85	40	540	G 3/8"	75	OAS150GCA - 06138
81527	100	50	400	760	115	85	40	590	G 3/8"	75	OAS150GCA - 06138
81528	100	50	450	810	115	85	40	640	G 3/8"	75	OAS150GCA - 06138
81529	100	50	500	860	115	85	40	690	G 3/8"	75	OAS150GCA - 06138
81530	100	50	550	910	115	85	40	740	G 3/8"	75	OAS150GCA - 06138
81531	100	50	600	960	115	85	40	790	G 3/8"	75	OAS150GCA - 06138
81532	100	50	650	1010	115	85	40	840	G 3/8"	75	OAS150GCA - 06138
81533	100	50	700	1060	115	85	40	890	G 3/8"	75	OAS150GCA - 06138
81534	100	50	750	1110	115	85	40	940	G 3/8"	75	OAS150GCA - 06138
81535	100	50	800	1160	115	85	40	990	G 3/8"	75	OAS150GCA - 06138
81536	100	50	850	1210	115	85	40	1040	G 3/8"	75	OAS150GCA - 06138
81537	100	50	900	1260	115	85	40	1090	G 3/8"	75	OAS150GCA - 06138
81538	100	50	950	1310	115	85	40	1140	G 3/8"	75	OAS150GCA - 06138
81539	100	50	1000	1360	115	85	40	1190	G 3/8"	75	OAS150GCA - 06138
81540	100	60	100	460	115	85	40	290	G 3/8"	75	OAS160GCA - 06138
81541	100	60	150	510	115	85	40	340	G 3/8"	75	OAS160GCA - 06138
81542	100	60	200	560	115	85	40	390	G 3/8"	75	OAS160GCA - 06138
81543	100	60	250	610	115	85	40	440	G 3/8"	75	OAS160GCA - 06138
81544	100	60	300	660	115	85	40	490	G 3/8"	75	OAS160GCA - 06138
81545	100	60	350	710	115	85	40	540	G 3/8"	75	OAS160GCA - 06138
81546	100	60	400	760	115	85	40	590	G 3/8"	75	OAS160GCA - 06138

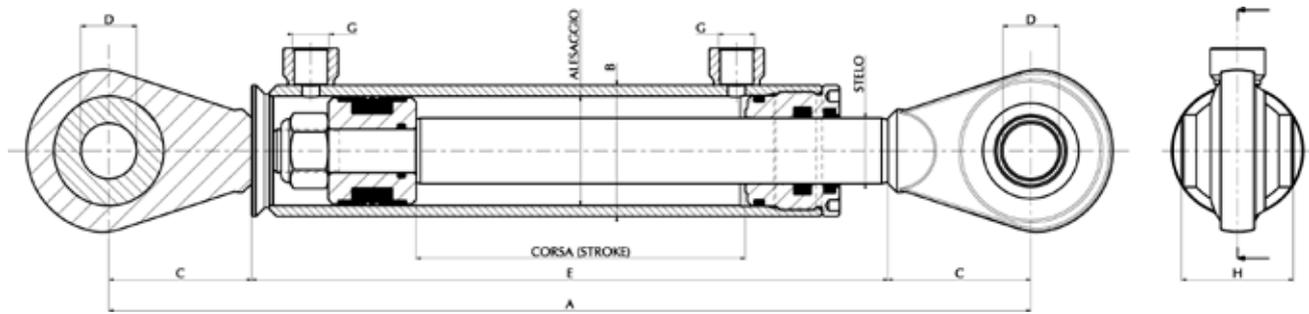

Art./Ref.	Alesaggio/ Bore	Stelo Ø/ Rod Ø	Corsa/ Stroke	Misura A mm/ A size mm	Misura B mm/ B size mm	Misura C mm/ C size mm	Misura D mm/ D size mm	Misura E mm/ E size mm	Misura G mm/ G size mm	Misura H mm/ H size mm	Kit testa-kit pistone/ Rod guide kit-piston kit
81547	100	60	450	810	115	85	40	640	G 3/8"	75	OAS160GCA - 06138
81548	100	60	500	860	115	85	40	690	G 3/8"	75	OAS160GCA - 06138
81549	100	60	550	910	115	85	40	740	G 3/8"	75	OAS160GCA - 06138
81550	100	60	600	960	115	85	40	790	G 3/8"	75	OAS160GCA - 06138
81551	100	60	650	1010	115	85	40	840	G 3/8"	75	OAS160GCA - 06138
81552	100	60	700	1060	115	85	40	890	G 3/8"	75	OAS160GCA - 06138
81553	100	60	750	1110	115	85	40	940	G 3/8"	75	OAS160GCA - 06138
81554	100	60	800	1160	115	85	40	990	G 3/8"	75	OAS160GCA - 06138
81555	100	60	850	1210	115	85	40	1040	G 3/8"	75	OAS160GCA - 06138
81556	100	60	900	1260	115	85	40	1090	G 3/8"	75	OAS160GCA - 06138
81557	100	60	950	1310	115	85	40	1140	G 3/8"	75	OAS160GCA - 06138
81558	100	60	1000	1360	115	85	40	1190	G 3/8"	75	OAS160GCA - 06138

CILINDRI A DOPPIO EFFETTO CON SNODI INDUSTRIALI

VERINS A DOUBLE EFFET AVEC ROTULES INDUSTRIELLES
 HYDRAULIC CYLINDERS DOUBLE ACTING WITH INDUSTRIAL JOINTS
 HYDRAULISCHE ZYLINDER DOPPELWIRKEND MIT INDUSTRIELLE GELENKE
 CILINDROS DOBLE EFECTO CON COJINETES INDUSTRIALES
 ЦИЛИНДРЫ ДВОЙНОГО ДЕЙСТВИЯ С ПРОМЫШЛЕННЫМ ШАРНИРОМ

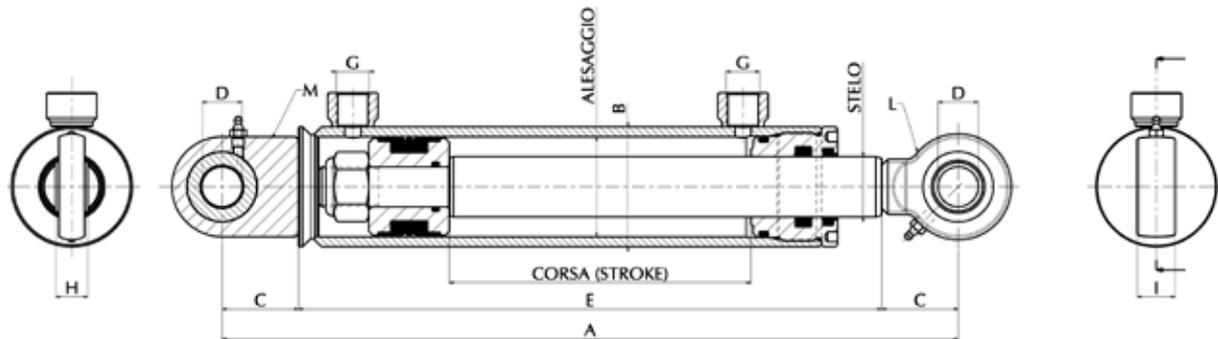

Art./Ref.	Alesaggio/ Bore	Stelo Ø/ Rod Ø	Corsa/ Stroke	Misura A mm/A size mm	Misura B mm/B size mm	Misura C mm/C size mm	Misura D mm/D size mm	Misura E mm/E size mm	Misura G mm/G size mm	Misura H mm/H size mm	Misura I mm/I size mm	Misura L mm/L size mm	Misura M mm/M size mm	Kit testa-kit pistone/ Rod guide kit-piston kit
81665	40	20	50	250	50	35	16	180	G 1/4"	14	18	OTS16AR	OTS16PR	OAS4020GC - 06130
81666	40	20	100	300	50	35	16	230	G 1/4"	14	18	OTS16AR	OTS16PR	OAS4020GC - 06130
81667	40	20	150	350	50	35	16	280	G 1/4"	14	18	OTS16AR	OTS16PR	OAS4020GC - 06130
81668	40	20	200	400	50	35	16	330	G 1/4"	14	18	OTS16AR	OTS16PR	OAS4020GC - 06130
81669	40	20	250	450	50	35	16	380	G 1/4"	14	18	OTS16AR	OTS16PR	OAS4020GC - 06130
81670	40	20	300	500	50	35	16	430	G 1/4"	14	18	OTS16AR	OTS16PR	OAS4020GC - 06130
81671	40	20	350	550	50	35	16	480	G 1/4"	14	18	OTS16AR	OTS16PR	OAS4020GC - 06130
81672	40	20	400	600	50	35	16	530	G 1/4"	14	18	OTS16AR	OTS16PR	OAS4020GC - 06130
81673	40	20	450	650	50	35	16	580	G 1/4"	14	18	OTS16AR	OTS16PR	OAS4020GC - 06130
81674	40	20	500	700	50	35	16	630	G 1/4"	14	18	OTS16AR	OTS16PR	OAS4020GC - 06130
81675	40	20	550	750	50	35	16	680	G 1/4"	14	18	OTS16AR	OTS16PR	OAS4020GC - 06130
81676	40	20	600	800	50	35	16	730	G 1/4"	14	18	OTS16AR	OTS16PR	OAS4020GC - 06130
81677	40	20	650	850	50	35	16	780	G 1/4"	14	18	OTS16AR	OTS16PR	OAS4020GC - 06130

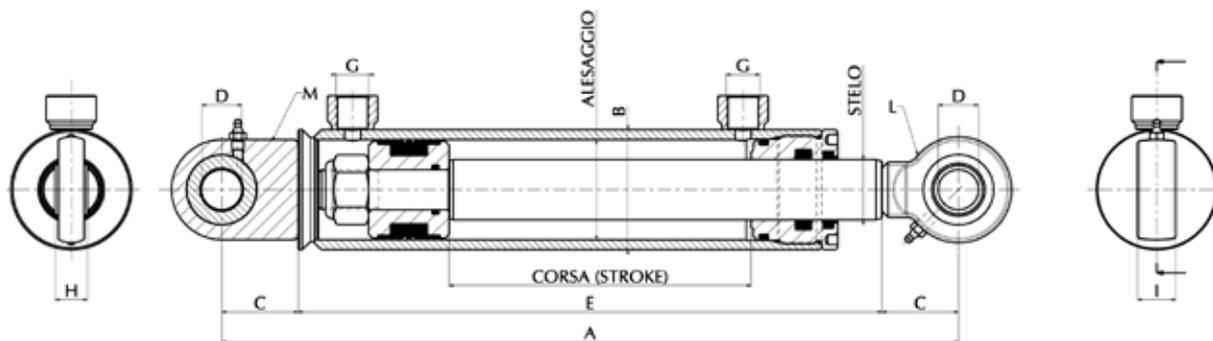

Art./ Ref.	Alesaggio/ Bore	Stelo Ø/ Rod Ø	Corsa/ Stroke	Misura A mm/A size mm	Misura B mm/B size mm	Misura C mm/C size mm	Misura D mm/D size mm	Misura E mm/E size mm	Misura G mm/G size mm	Misura H mm/H size mm	Misura I mm/I size mm	Misura L mm/L size mm	Misura M mm/M size mm	Kit testa-kit pistone/ Rod guide kit-piston kit
81678	40	20	700	900	50	35	16	830	G 1/4"	14	18	OTS16AR	OTS16PR	OAS4020GC - 06130
81679	40	20	750	950	50	35	16	880	G 1/4"	14	18	OTS16AR	OTS16PR	OAS4020GC - 06130
81680	40	20	800	1000	50	35	16	930	G 1/4"	14	18	OTS16AR	OTS16PR	OAS4020GC - 06130
81681	40	20	850	1050	50	35	16	980	G 1/4"	14	18	OTS16AR	OTS16PR	OAS4020GC - 06130
81682	40	20	900	1100	50	35	16	1030	G 1/4"	14	18	OTS16AR	OTS16PR	OAS4020GC - 06130
81683	40	20	950	1150	50	35	16	1080	G 1/4"	14	18	OTS16AR	OTS16PR	OAS4020GC - 06130
81684	40	20	1000	1200	50	35	16	1130	G 1/4"	14	18	OTS16AR	OTS16PR	OAS4020GC - 06130
81685	40	25	50	250	50	35	16	180	G 1/4"	14	18	OTS16AR	OTS16PR	OAS4025GC - 06130
81686	40	25	100	300	50	35	16	230	G 1/4"	14	18	OTS16AR	OTS16PR	OAS4025GC - 06130
81687	40	25	150	350	50	35	16	280	G 1/4"	14	18	OTS16AR	OTS16PR	OAS4020GC - 06130
81688	40	25	200	400	50	35	16	330	G 1/4"	14	18	OTS16AR	OTS16PR	OAS4025GC - 06130
81689	40	25	250	450	50	35	16	380	G 1/4"	14	18	OTS16AR	OTS16PR	OAS4025GC - 06130
81690	40	25	300	500	50	35	16	430	G 1/4"	14	18	OTS16AR	OTS16PR	OAS4025GC - 06130
81691	40	25	350	550	50	35	16	480	G 1/4"	14	18	OTS16AR	OTS16PR	OAS4025GC - 06130
81692	40	25	400	600	50	35	16	530	G 1/4"	14	18	OTS16AR	OTS16PR	OAS4025GC - 06130
81693	40	25	450	650	50	35	16	580	G 1/4"	14	18	OTS16AR	OTS16PR	OAS4025GC - 06130
81694	40	25	500	700	50	35	16	630	G 1/4"	14	18	OTS16AR	OTS16PR	OAS4025GC - 06130
81695	40	25	550	750	50	35	16	680	G 1/4"	14	18	OTS16AR	OTS16PR	OAS4025GC - 06130
81696	40	25	600	800	50	35	16	730	G 1/4"	14	18	OTS16AR	OTS16PR	OAS4025GC - 06130
81697	40	25	650	850	50	35	16	780	G 1/4"	14	18	OTS16AR	OTS16PR	OAS4025GC - 06130
81698	40	25	700	900	50	35	16	830	G 1/4"	14	18	OTS16AR	OTS16PR	OAS4025GC - 06130
81699	40	25	750	950	50	35	16	880	G 1/4"	14	18	OTS16AR	OTS16PR	OAS4025GC - 06130
81700	40	25	800	1000	50	35	16	930	G 1/4"	14	18	OTS16AR	OTS16PR	OAS4025GC - 06130
81701	40	25	850	1050	50	35	16	980	G 1/4"	14	18	OTS16AR	OTS16PR	OAS4025GC - 06130
81702	40	25	900	1100	50	35	16	1030	G 1/4"	14	18	OTS16AR	OTS16PR	OAS4025GC - 06130
81703	40	25	950	1150	50	35	16	1080	G 1/4"	14	18	OTS16AR	OTS16PR	OAS4025GC - 06130
81704	40	25	1000	1200	50	35	16	1130	G 1/4"	14	18	OTS16AR	OTS16PR	OAS4025GC - 06130
81705	50	25	100	316	60	38	20	240	G 3/8"	16	19	04969	05004	OAS5025GC - 06132
81706	50	25	150	366	60	38	20	290	G 3/8"	16	19	04969	05004	OAS5025GC - 06132
81707	50	25	200	416	60	38	20	340	G 3/8"	16	19	04969	05004	OAS5025GC - 06132
81708	50	25	250	466	60	38	20	390	G 3/8"	16	19	04969	05004	OAS5025GC - 06132
81709	50	25	300	516	60	38	20	440	G 3/8"	16	19	04969	05004	OAS5025GC - 06132
81710	50	25	350	566	60	38	20	490	G 3/8"	16	19	04969	05004	OAS5025GC - 06132
81711	50	25	400	616	60	38	20	540	G 3/8"	16	19	04969	05004	OAS5025GC - 06132
81712	50	25	450	666	60	38	20	590	G 3/8"	16	19	04969	05004	OAS5025GC - 06132
81713	50	25	500	716	60	38	20	640	G 3/8"	16	19	04969	05004	OAS5025GC - 06132
81714	50	25	550	766	60	38	20	690	G 3/8"	16	19	04969	05004	OAS5025GC - 06132
81715	50	25	600	816	60	38	20	740	G 3/8"	16	19	04969	05004	OAS5025GC - 06132
81716	50	25	650	866	60	38	20	790	G 3/8"	16	19	04969	05004	OAS5025GC - 06132
81717	50	25	700	916	60	38	20	840	G 3/8"	16	19	04969	05004	OAS5025GC - 06132
81718	50	25	750	966	60	38	20	890	G 3/8"	16	19	04969	05004	OAS5025GC - 06132
81719	50	25	800	1016	60	38	20	940	G 3/8"	16	19	04969	05004	OAS5025GC - 06132
81720	50	25	850	1066	60	38	20	990	G 3/8"	16	19	04969	05004	OAS5025GC - 06132
81721	50	25	900	1116	60	38	20	1040	G 3/8"	16	19	04969	05004	OAS5025GC - 06132
81722	50	25	950	1166	60	38	20	1090	G 3/8"	16	19	04969	05004	OAS5025GC - 06132
81723	50	25	1000	1216	60	38	20	1140	G 3/8"	16	19	04969	05004	OAS5025GC - 06132
81724	50	30	100	316	60	38	20	240	G 3/8"	16	19	04969	05004	OAS5030GC - 06132

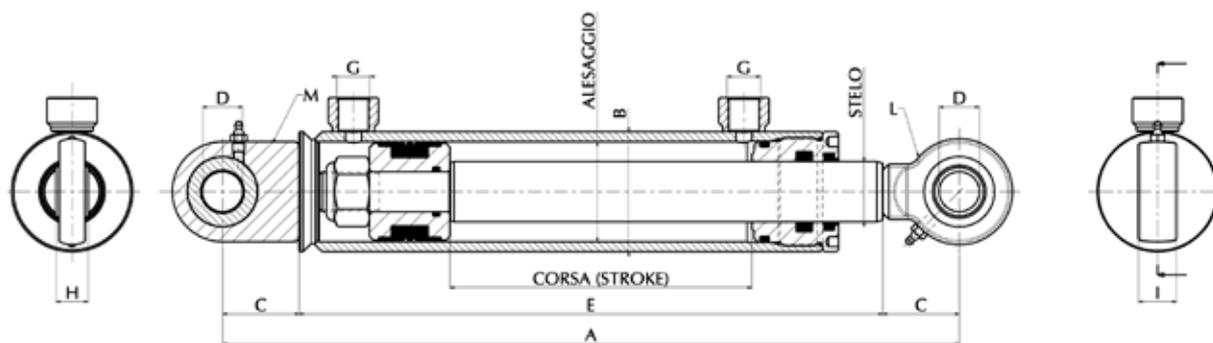

Art./ Ref.	Alesaggio/ Bore	Stelo Ø/ Rod Ø	Corsa/ Stroke	Misura A mm/A size mm	Misura B mm/B size mm	Misura C mm/C size mm	Misura D mm/D size mm	Misura E mm/E size mm	Misura G mm/G size mm	Misura H mm/H size mm	Misura I mm/I size mm	Misura L mm/L size mm	Misura M mm/M size mm	Kit testa-kit pistone/ Rod guide kit-piston kit
81725	50	30	150	366	60	38	20	290	G 3/8"	16	19	04969	05004	0AS5030GC - 06132
81726	50	30	200	416	60	38	20	340	G 3/8"	16	19	04969	05004	0AS5030GC - 06132
81727	50	30	250	466	60	38	20	390	G 3/8"	16	19	04969	05004	0AS5030GC - 06132
81728	50	30	300	516	60	38	20	440	G 3/8"	16	19	04969	05004	0AS5030GC - 06132
81729	50	30	350	566	60	38	20	490	G 3/8"	16	19	04969	05004	0AS5030GC - 06132
81730	50	30	400	616	60	38	20	540	G 3/8"	16	19	04969	05004	0AS5030GC - 06132
81731	50	30	450	666	60	38	20	590	G 3/8"	16	19	04969	05004	0AS5030GC - 06132
81732	50	30	500	716	60	38	20	640	G 3/8"	16	19	04969	05004	0AS5030GC - 06132
81733	50	30	550	766	60	38	20	690	G 3/8"	16	19	04969	05004	0AS5030GC - 06132
81734	50	30	600	816	60	38	20	740	G 3/8"	16	19	04969	05004	0AS5030GC - 06132
81735	50	30	650	866	60	38	20	790	G 3/8"	16	19	04969	05004	0AS5030GC - 06132
81736	50	30	700	916	60	38	20	840	G 3/8"	16	19	04969	05004	0AS5030GC - 06132
81737	50	30	750	966	60	38	20	890	G 3/8"	16	19	04969	05004	0AS5030GC - 06132
81738	50	30	800	1016	60	38	20	940	G 3/8"	16	19	04969	05004	0AS5030GC - 06132
81739	50	30	850	1066	60	38	20	990	G 3/8"	16	19	04969	05004	0AS5030GC - 06132
81740	50	30	900	1116	60	38	20	1040	G 3/8"	16	19	04969	05004	0AS5030GC - 06132
81741	50	30	950	1166	60	38	20	1090	G 3/8"	16	19	04969	05004	0AS5030GC - 06132
81742	50	30	1000	1216	60	38	20	1140	G 3/8"	16	19	04969	05004	0AS5030GC - 06132
81743	60	30	100	350	70	45	25	260	G 3/8"	20	23	04970	05005	0AS6030GC - 06133
81744	60	30	150	400	70	45	25	310	G 3/8"	20	23	04970	05005	0AS6030GC - 06133
81745	60	30	200	450	70	45	25	360	G 3/8"	20	23	04970	05005	0AS6030GC - 06133
81746	60	30	250	500	70	45	25	410	G 3/8"	20	23	04970	05005	0AS6030GC - 06133
81747	60	30	300	550	70	45	25	460	G 3/8"	20	23	04970	05005	0AS6030GC - 06133
81748	60	30	350	600	70	45	25	510	G 3/8"	20	23	04970	05005	0AS6030GC - 06133
81749	60	30	400	650	70	45	25	560	G 3/8"	20	23	04970	05005	0AS6030GC - 06133
81750	60	30	450	700	70	45	25	610	G 3/8"	20	23	04970	05005	0AS6030GC - 06133
81751	60	30	500	750	70	45	25	660	G 3/8"	20	23	04970	05005	0AS6030GC - 06133
81752	60	30	550	800	70	45	25	710	G 3/8"	20	23	04970	05005	0AS6030GC - 06133
81753	60	30	600	850	70	45	25	760	G 3/8"	20	23	04970	05005	0AS6030GC - 06133
81754	60	30	650	900	70	45	25	810	G 3/8"	20	23	04970	05005	0AS6030GC - 06133
81755	60	30	700	950	70	45	25	860	G 3/8"	20	23	04970	05005	0AS6030GC - 06133
81756	60	30	750	1000	70	45	25	910	G 3/8"	20	23	04970	05005	0AS6030GC - 06133
81757	60	30	800	1050	70	45	25	960	G 3/8"	20	23	04970	05005	0AS6030GC - 06133
81758	60	30	850	1100	70	45	25	1010	G 3/8"	20	23	04970	05005	0AS6030GC - 06133
81759	60	30	900	1150	70	45	25	1060	G 3/8"	20	23	04970	05005	0AS6030GC - 06133
81760	60	30	950	1200	70	45	25	1110	G 3/8"	20	23	04970	05005	0AS6030GC - 06133
81761	60	30	1000	1250	70	45	25	1160	G 3/8"	20	23	04970	05005	0AS6030GC - 06133
81762	60	35	100	350	70	45	25	260	G 3/8"	20	23	04970	05005	0AS6035GC - 06133
81763	60	35	150	400	70	45	25	310	G 3/8"	20	23	04970	05005	0AS6035GC - 06133
81764	60	35	200	450	70	45	25	360	G 3/8"	20	23	04970	05005	0AS6035GC - 06133
81765	60	35	250	500	70	45	25	410	G 3/8"	20	23	04970	05005	0AS6035GC - 06133
81766	60	35	300	550	70	45	25	460	G 3/8"	20	23	04970	05005	0AS6035GC - 06133
81767	60	35	350	600	70	45	25	510	G 3/8"	20	23	04970	05005	0AS6035GC - 06133
81768	60	35	400	650	70	45	25	560	G 3/8"	20	23	04970	05005	0AS6035GC - 06133
81769	60	35	450	700	70	45	25	610	G 3/8"	20	23	04970	05005	0AS6035GC - 06133
81770	60	35	500	750	70	45	25	660	G 3/8"	20	23	04970	05005	0AS6035GC - 06133
81771	60	35	550	800	70	45	25	710	G 3/8"	20	23	04970	05005	0AS6035GC - 06133

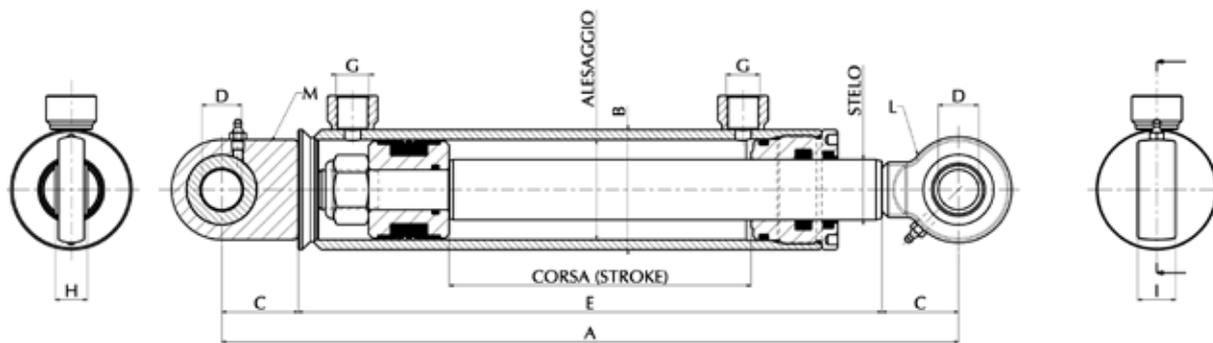

Art./ Ref.	Alesaggio/ Bore	Stelo Ø/ Rod Ø	Corsa/ Stroke	Misura A mm/A size mm	Misura B mm/B size mm	Misura C mm/C size mm	Misura D mm/D size mm	Misura E mm/E size mm	Misura G mm/G size mm	Misura H mm/H size mm	Misura I mm/I size mm	Misura L mm/L size mm	Misura M mm/M size mm	Kit testa-kit pistone/ Rod guide kit-piston kit
81772	60	35	600	850	70	45	25	760	G 3/8"	20	23	04970	05005	0AS6035GC - 06133
81773	60	35	650	900	70	45	25	810	G 3/8"	20	23	04970	05005	0AS6035GC - 06133
81914	60	35	700	950	70	45	25	860	G 3/8"	20	23	04970	05005	0AS6035GC - 06133
81775	60	35	750	1000	70	45	25	910	G 3/8"	20	23	04970	05005	0AS6035GC - 06133
81776	60	35	800	1050	70	45	25	960	G 3/8"	20	23	04970	05005	0AS6035GC - 06133
81777	60	35	850	1100	70	45	25	1010	G 3/8"	20	23	04970	05005	0AS6035GC - 06133
81778	60	35	900	1150	70	45	25	1060	G 3/8"	20	23	04970	05005	0AS6035GC - 06133
81779	60	35	950	1200	70	45	25	1110	G 3/8"	20	23	04970	05005	0AS6035GC - 06133
81780	60	35	1000	1250	70	45	25	1160	G 3/8"	20	23	04970	05005	0AS6035GC - 06133
81781	60	40	100	350	70	45	25	260	G 3/8"	20	23	04970	05005	0AS6040GC - 18219
81782	60	40	150	400	70	45	25	310	G 3/8"	20	23	04970	05005	0AS6040GC - 18219
81783	60	40	200	450	70	45	25	360	G 3/8"	20	23	04970	05005	0AS6040GC - 18219
81784	60	40	250	500	70	45	25	410	G 3/8"	20	23	04970	05005	0AS6040GC - 18219
81785	60	40	300	550	70	45	25	460	G 3/8"	20	23	04970	05005	0AS6040GC - 18219
81786	60	40	350	600	70	45	25	510	G 3/8"	20	23	04970	05005	0AS6040GC - 18219
81787	60	40	400	650	70	45	25	560	G 3/8"	20	23	04970	05005	0AS6040GC - 18219
81788	60	40	450	700	70	45	25	610	G 3/8"	20	23	04970	05005	0AS6040GC - 18219
81789	60	40	500	750	70	45	25	660	G 3/8"	20	23	04970	05005	0AS6040GC - 18219
81790	60	40	550	800	70	45	25	710	G 3/8"	20	23	04970	05005	0AS6040GC - 18219
81791	60	40	600	850	70	45	25	760	G 3/8"	20	23	04970	05005	0AS6040GC - 18219
81792	60	40	650	900	70	45	25	810	G 3/8"	20	23	04970	05005	0AS6040GC - 18219
81793	60	40	700	950	70	45	25	860	G 3/8"	20	23	04970	05005	0AS6040GC - 18219
81794	60	40	750	1000	70	45	25	910	G 3/8"	20	23	04970	05005	0AS6040GC - 18219
81795	60	40	800	1050	70	45	25	960	G 3/8"	20	23	04970	05005	0AS6040GC - 18219
81796	60	40	850	1100	70	45	25	1010	G 3/8"	20	23	04970	05005	0AS6040GC - 18219
81797	60	40	900	1150	70	45	25	1060	G 3/8"	20	23	04970	05005	0AS6040GC - 18219
81798	60	40	950	1200	70	45	25	1110	G 3/8"	20	23	04970	05005	0AS6040GC - 18219
81799	60	40	1000	1250	70	45	25	1160	G 3/8"	20	23	04970	05005	0AS6040GC - 18219
81800	70	35	100	350	80	45	25	260	G 3/8"	20	23	04970	05005	0AS7035GC - 06135
81801	70	35	150	400	80	45	25	310	G 3/8"	20	23	04970	05005	0AS7035GC - 06135
81802	70	35	200	450	80	45	25	360	G 3/8"	20	23	04970	05005	0AS7035GC - 06135
81803	70	35	250	500	80	45	25	410	G 3/8"	20	23	04970	05005	0AS7035GC - 06135
81804	70	35	300	550	80	45	25	460	G 3/8"	20	23	04970	05005	0AS7035GC - 06135
81805	70	35	350	600	80	45	25	510	G 3/8"	20	23	04970	05005	0AS7035GC - 06135
81806	70	35	400	650	80	45	25	560	G 3/8"	20	23	04970	05005	0AS7035GC - 06135
81807	70	35	450	700	80	45	25	610	G 3/8"	20	23	04970	05005	0AS7035GC - 06135
81808	70	35	500	750	80	45	25	660	G 3/8"	20	23	04970	05005	0AS7035GC - 06135
81809	70	35	550	800	80	45	25	710	G 3/8"	20	23	04970	05005	0AS7035GC - 06135
81810	70	35	600	850	80	45	25	760	G 3/8"	20	23	04970	05005	0AS7035GC - 06135
81811	70	35	650	900	80	45	25	810	G 3/8"	20	23	04970	05005	0AS7035GC - 06135
81812	70	35	700	950	80	45	25	860	G 3/8"	20	23	04970	05005	0AS7035GC - 06135
81813	70	35	750	1000	80	45	25	910	G 3/8"	20	23	04970	05005	0AS7035GC - 06135
81814	70	35	800	1050	80	45	25	960	G 3/8"	20	23	04970	05005	0AS7035GC - 06135
81815	70	35	850	1100	80	45	25	1010	G 3/8"	20	23	04970	05005	0AS7035GC - 06135
81816	70	35	900	1150	80	45	25	1060	G 3/8"	20	23	04970	05005	0AS7035GC - 06135
81817	70	35	950	1200	80	45	25	1110	G 3/8"	20	23	04970	05005	0AS7035GC - 06135
81818	70	35	1000	1250	80	45	25	1160	G 3/8"	20	23	04970	05005	0AS7035GC - 06135

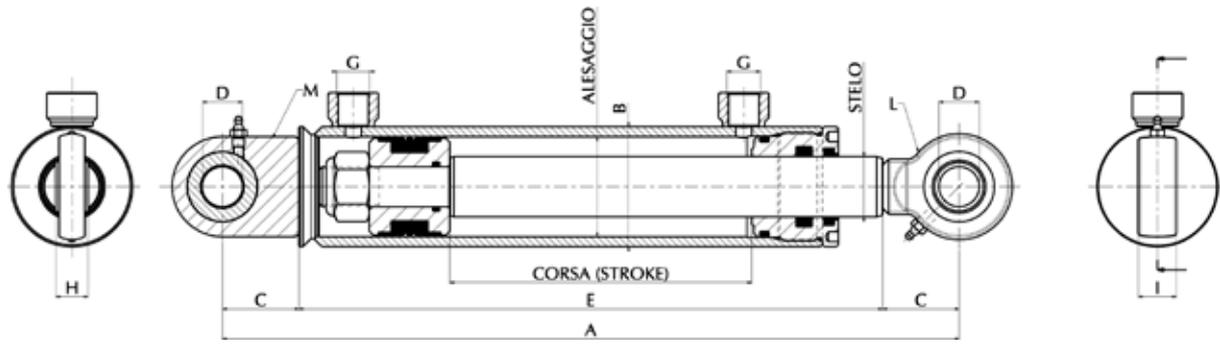

Art./ Ref.	Alesaggio/ Bore	Stelo Ø/ Rod Ø	Corsa/ Stroke	Misura A mm/A size mm	Misura B mm/B size mm	Misura C mm/C size mm	Misura D mm/D size mm	Misura E mm/E size mm	Misura G mm/G size mm	Misura H mm/H size mm	Misura I mm/I size mm	Misura L mm/L size mm	Misura M mm/M size mm	Kit testa-kit pistone/ Rod guide kit-piston kit
81819	70	40	100	350	80	45	25	260	G 3/8"	20	23	04970	05005	0AS7040GC - 06135
81820	70	40	150	400	80	45	25	310	G 3/8"	20	23	04970	05005	0AS7040GC - 06135
81821	70	40	200	450	80	45	25	360	G 3/8"	20	23	04970	05005	0AS7040GC - 06135
81822	70	40	250	500	80	45	25	410	G 3/8"	20	23	04970	05005	0AS7040GC - 06135
81823	70	40	300	550	80	45	25	460	G 3/8"	20	23	04970	05005	0AS7040GC - 06135
81824	70	40	350	600	80	45	25	510	G 3/8"	20	23	04970	05005	0AS7040GC - 06135
81825	70	40	400	650	80	45	25	560	G 3/8"	20	23	04970	05005	0AS7040GC - 06135
81826	70	40	450	700	80	45	25	610	G 3/8"	20	23	04970	05005	0AS7040GC - 06135
81827	70	40	500	750	80	45	25	660	G 3/8"	20	23	04970	05005	0AS7040GC - 06135
81828	70	40	550	800	80	45	25	710	G 3/8"	20	23	04970	05005	0AS7040GC - 06135
81829	70	40	600	850	80	45	25	760	G 3/8"	20	23	04970	05005	0AS7040GC - 06135
81830	70	40	650	900	80	45	25	810	G 3/8"	20	23	04970	05005	0AS7040GC - 06135
81831	70	40	700	950	80	45	25	860	G 3/8"	20	23	04970	05005	0AS7040GC - 06135
81832	70	40	750	1000	80	45	25	910	G 3/8"	20	23	04970	05005	0AS7040GC - 06135
81833	70	40	800	1050	80	45	25	960	G 3/8"	20	23	04970	05005	0AS7040GC - 06135
81834	70	40	850	1100	80	45	25	1010	G 3/8"	20	23	04970	05005	0AS7040GC - 06135
81835	70	40	900	1150	80	45	25	1060	G 3/8"	20	23	04970	05005	0AS7040GC - 06135
81836	70	40	950	1200	80	45	25	1110	G 3/8"	20	23	04970	05005	0AS7040GC - 06135
81837	70	40	1000	1250	80	45	25	1160	G 3/8"	20	23	04970	05005	0AS7040GC - 06135
81838	80	40	100	377	95	51	30	275	G 3/8"	22	28	04971	05006	0AS8040GC - 06136
81839	80	40	150	427	95	51	30	325	G 3/8"	22	28	04971	05006	0AS8040GC - 06136
81840	80	40	200	477	95	51	30	375	G 3/8"	22	28	04971	05006	0AS8040GC - 06136
81841	80	40	250	527	95	51	30	425	G 3/8"	22	28	04971	05006	0AS8040GC - 06136
81842	80	40	300	577	95	51	30	475	G 3/8"	22	28	04971	05006	0AS8040GC - 06136
81843	80	40	350	627	95	51	30	525	G 3/8"	22	28	04971	05006	0AS8040GC - 06136
81844	80	40	400	677	95	51	30	575	G 3/8"	22	28	04971	05006	0AS8040GC - 06136
81845	80	40	450	727	95	51	30	625	G 3/8"	22	28	04971	05006	0AS8040GC - 06136
81846	80	40	500	777	95	51	30	675	G 3/8"	22	28	04971	05006	0AS8040GC - 06136
81847	80	40	550	827	95	51	30	725	G 3/8"	22	28	04971	05006	0AS8040GC - 06136
81848	80	40	600	877	95	51	30	775	G 3/8"	22	28	04971	05006	0AS8040GC - 06136
81849	80	40	650	927	95	51	30	825	G 3/8"	22	28	04971	05006	0AS8040GC - 06136
81850	80	40	700	977	95	51	30	875	G 3/8"	22	28	04971	05006	0AS8040GC - 06136
81851	80	40	750	1027	95	51	30	925	G 3/8"	22	28	04971	05006	0AS8040GC - 06136
81852	80	40	800	1077	95	51	30	975	G 3/8"	22	28	04971	05006	0AS8040GC - 06136
81853	80	40	850	1127	95	51	30	1025	G 3/8"	22	28	04971	05006	0AS8040GC - 06136
81854	80	40	900	1177	95	51	30	1075	G 3/8"	22	28	04971	05006	0AS8040GC - 06136
81855	80	40	950	1227	95	51	30	1125	G 3/8"	22	28	04971	05006	0AS8040GC - 06136
81856	80	40	1000	1277	95	51	30	1175	G 3/8"	22	28	04971	05006	0AS8040GC - 06136
81857	80	50	100	377	95	51	30	275	G 3/8"	22	28	04971	05006	0AS8050GC - 06136
81858	80	50	150	427	95	51	30	325	G 3/8"	22	28	04971	05006	0AS8050GC - 06136
81859	80	50	200	477	95	51	30	375	G 3/8"	22	28	04971	05006	0AS8050GC - 06136
81860	80	50	250	527	95	51	30	425	G 3/8"	22	28	04971	05006	0AS8050GC - 06136
81861	80	50	300	577	95	51	30	475	G 3/8"	22	28	04971	05006	0AS8050GC - 06136
81862	80	50	350	627	95	51	30	525	G 3/8"	22	28	04971	05006	0AS8050GC - 06136
81863	80	50	400	677	95	51	30	575	G 3/8"	22	28	04971	05006	0AS8050GC - 06136
81864	80	50	450	727	95	51	30	625	G 3/8"	22	28	04971	05006	0AS8050GC - 06136
81865	80	50	500	777	95	51	30	675	G 3/8"	22	28	04971	05006	0AS8050GC - 06136

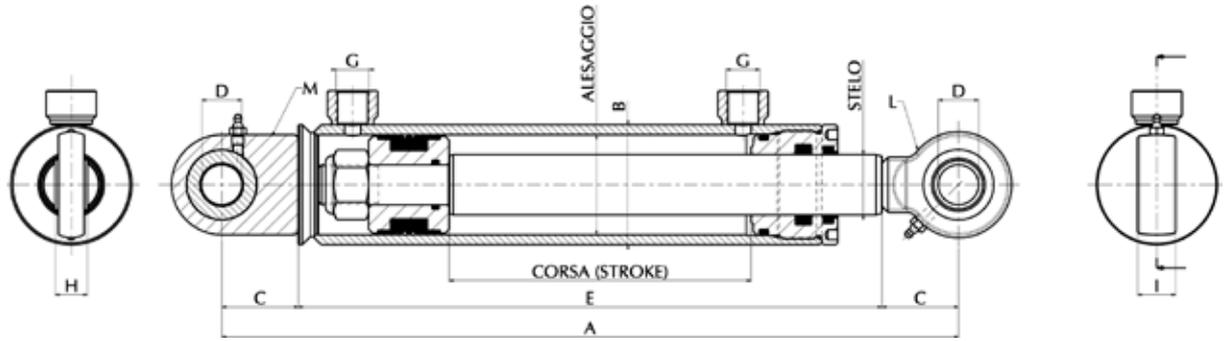

Art./ Ref.	Alesaggio/ Bore	Stelo Ø/ Rod Ø	Corsa/ Stroke	Misura A mm/A size mm	Misura B mm/B size mm	Misura C mm/C size mm	Misura D mm/D size mm	Misura E mm/E size mm	Misura G mm/G size mm	Misura H mm/H size mm	Misura I mm/I size mm	Misura L mm/L size mm	Misura M mm/M size mm	Kit testa-kit pistone/ Rod guide kit-piston kit
81866	80	50	550	827	95	51	30	725	G 3/8"	22	28	04971	05006	0AS8050GC - 06136
81867	80	50	600	877	95	51	30	775	G 3/8"	22	28	04971	05006	0AS8050GC - 06136
81868	80	50	650	927	95	51	30	825	G 3/8"	22	28	04971	05006	0AS8050GC - 06136
81869	80	50	700	977	95	51	30	875	G 3/8"	22	28	04971	05006	0AS8050GC - 06136
81870	80	50	750	1027	95	51	30	925	G 3/8"	22	28	04971	05006	0AS8050GC - 06136
81871	80	50	800	1077	95	51	30	975	G 3/8"	22	28	04971	05006	0AS8050GC - 06136
81872	80	50	850	1127	95	51	30	1025	G 3/8"	22	28	04971	05006	0AS8050GC - 06136
81873	80	50	900	1177	95	51	30	1075	G 3/8"	22	28	04971	05006	0AS8050GC - 06136
81874	80	50	950	1227	95	51	30	1125	G 3/8"	22	28	04971	05006	0AS8050GC - 06136
81875	80	50	1000	1277	95	51	30	1175	G 3/8"	22	28	04971	05006	0AS8050GC - 06136
81876	100	50	100	428	115	69	40	290	G 3/8"	28	35	04676	04678	0AS150GCA - 06138
81877	100	50	150	478	115	69	40	340	G 3/8"	28	35	04676	04678	0AS150GCA - 06138
81878	100	50	200	528	115	69	40	390	G 3/8"	28	35	04676	04678	0AS150GCA - 06138
81879	100	50	250	578	115	69	40	440	G 3/8"	28	35	04676	04678	0AS150GCA - 06138
81880	100	50	300	628	115	69	40	490	G 3/8"	28	35	04676	04678	0AS150GCA - 06138
81881	100	50	350	678	115	69	40	540	G 3/8"	28	35	04676	04678	0AS150GCA - 06138
81882	100	50	400	728	115	69	40	590	G 3/8"	28	35	04676	04678	0AS150GCA - 06138
81883	100	50	450	778	115	69	40	640	G 3/8"	28	35	04676	04678	0AS150GCA - 06138
81884	100	50	500	828	115	69	40	690	G 3/8"	28	35	04676	04678	0AS150GCA - 06138
81885	100	50	550	878	115	69	40	740	G 3/8"	28	35	04676	04678	0AS150GCA - 06138
81886	100	50	600	928	115	69	40	790	G 3/8"	28	35	04676	04678	0AS150GCA - 06138
81887	100	50	650	978	115	69	40	840	G 3/8"	28	35	04676	04678	0AS150GCA - 06138
81888	100	50	700	1028	115	69	40	890	G 3/8"	28	35	04676	04678	0AS150GCA - 06138
81889	100	50	750	1078	115	69	40	940	G 3/8"	28	35	04676	04678	0AS150GCA - 06138
81890	100	50	800	1128	115	69	40	990	G 3/8"	28	35	04676	04678	0AS150GCA - 06138
81891	100	50	850	1178	115	69	40	1040	G 3/8"	28	35	04676	04678	0AS150GCA - 06138
81892	100	50	900	1228	115	69	40	1090	G 3/8"	28	35	04676	04678	0AS150GCA - 06138
81893	100	50	950	1278	115	69	40	1140	G 3/8"	28	35	04676	04678	0AS150GCA - 06138
81894	100	50	1000	1328	115	69	40	1190	G 3/8"	28	35	04676	04678	0AS150GCA - 06138
81895	100	60	100	428	115	69	40	290	G 3/8"	28	35	04676	04678	0AS160GCA - 06138
81896	100	60	150	478	115	69	40	340	G 3/8"	28	35	04676	04678	0AS160GCA - 06138
81897	100	60	200	528	115	69	40	390	G 3/8"	28	35	04676	04678	0AS160GCA - 06138
81898	100	60	250	578	115	69	40	440	G 3/8"	28	35	04676	04678	0AS160GCA - 06138
81899	100	60	300	628	115	69	40	490	G 3/8"	28	35	04676	04678	0AS160GCA - 06138
81900	100	60	350	678	115	69	40	540	G 3/8"	28	35	04676	04678	0AS160GCA - 06138
81901	100	60	400	728	115	69	40	590	G 3/8"	28	35	04676	04678	0AS160GCA - 06138
81902	100	60	450	778	115	69	40	640	G 3/8"	28	35	04676	04678	0AS160GCA - 06138
81903	100	60	500	828	115	69	40	690	G 3/8"	28	35	04676	04678	0AS160GCA - 06138
81904	100	60	550	878	115	69	40	740	G 3/8"	28	35	04676	04678	0AS160GCA - 06138
81905	100	60	600	928	115	69	40	790	G 3/8"	28	35	04676	04678	0AS160GCA - 06138
81906	100	60	650	978	115	69	40	840	G 3/8"	28	35	04676	04678	0AS160GCA - 06138
81907	100	60	700	1028	115	69	40	890	G 3/8"	28	35	04676	04678	0AS160GCA - 06138
81908	100	60	750	1078	115	69	40	940	G 3/8"	28	35	04676	04678	0AS160GCA - 06138
81909	100	60	800	1128	115	69	40	990	G 3/8"	28	35	04676	04678	0AS160GCA - 06138
81910	100	60	850	1178	115	69	40	1040	G 3/8"	28	35	04676	04678	0AS160GCA - 06138
81911	100	60	900	1228	115	69	40	1090	G 3/8"	28	35	04676	04678	0AS160GCA - 06138
81912	100	60	950	1278	115	69	40	1140	G 3/8"	28	35	04676	04678	0AS160GCA - 06138
81913	100	60	1000	1328	115	69	40	1190	G 3/8"	28	35	04676	04678	0AS160GCA - 06138

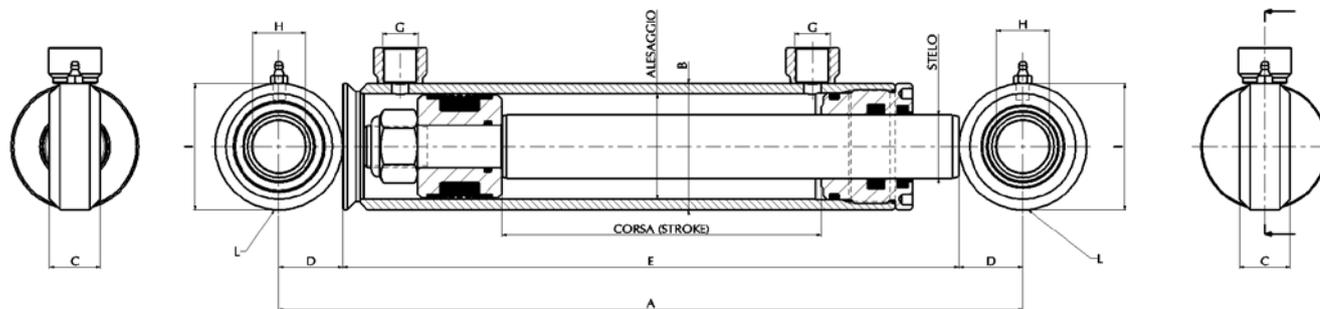
CILINDRI A DOPPIO EFFETTO CON ATTACCHI
VERINS DOUBLE EFFET AVEC FIXATIONES
HYDRAULIC CYLINDERS DOUBLE ACTING WITH ENDS
HYDRAULISCHE ZYLINDER DOPPELWIRKEND MIT ANSCHLÜSSE
CILINDROS DOBLE EFECTO CON FISACIONES
ЦИЛИНДРИ ДВОЙНОГО ДЕЙСТВИЯ С КРЕПЛЕНИЯМИ

Art./Ref.	Alesaggio/ Bore	Stelo Ø/Rod Ø	Corsa/Stroke	Misura A mm/A size mm	Misura B mm/B size mm	Misura C mm/C size mm	Misura D mm/D size mm	Misura E mm/E size mm	Misura G mm/G size mm	Misura H mm/H size mm	Misura I mm/I size mm	Misura L mm/L size mm	Kit testa-kit pistone/ Rod guide kit-piston kit
81915	40	20	50	230	50	25	25	180	G 1/4"	20	50	25	OAS4020GC - 06130
81916	40	20	100	280	50	25	25	230	G 1/4"	20	50	25	OAS4020GC - 06130
81917	40	20	150	330	50	25	25	280	G 1/4"	20	50	25	OAS4020GC - 06130
81918	40	20	200	380	50	25	25	330	G 1/4"	20	50	25	OAS4020GC - 06130
81919	40	20	250	430	50	25	25	380	G 1/4"	20	50	25	OAS4020GC - 06130
81920	40	20	300	480	50	25	25	430	G 1/4"	20	50	25	OAS4020GC - 06130
81921	40	20	350	530	50	25	25	480	G 1/4"	20	50	25	OAS4020GC - 06130
81922	40	20	400	580	50	25	25	530	G 1/4"	20	50	25	OAS4020GC - 06130
81923	40	20	450	630	50	25	25	580	G 1/4"	20	50	25	OAS4020GC - 06130
81924	40	20	500	680	50	25	25	630	G 1/4"	20	50	25	OAS4020GC - 06130
81925	40	20	550	730	50	25	25	680	G 1/4"	20	50	25	OAS4020GC - 06130
81926	40	20	600	780	50	25	25	730	G 1/4"	20	50	25	OAS4020GC - 06130
81927	40	20	650	830	50	25	25	780	G 1/4"	20	50	25	OAS4020GC - 06130
81928	40	20	700	880	50	25	25	830	G 1/4"	20	50	25	OAS4020GC - 06130
81929	40	20	750	930	50	25	25	880	G 1/4"	20	50	25	OAS4020GC - 06130
81930	40	20	800	980	50	25	25	930	G 1/4"	20	50	25	OAS4020GC - 06130
81931	40	20	850	1030	50	25	25	980	G 1/4"	20	50	25	OAS4020GC - 06130
81932	40	20	900	1080	50	25	25	1030	G 1/4"	20	50	25	OAS4020GC - 06130
81933	40	20	950	1130	50	25	25	1080	G 1/4"	20	50	25	OAS4020GC - 06130
81934	40	20	1000	1180	50	25	25	1130	G 1/4"	20	50	25	OAS4020GC - 06130
81935	40	25	50	230	50	25	25	180	G 1/4"	20	50	25	OAS4025GC - 06130
81936	40	25	100	280	50	25	25	230	G 1/4"	20	50	25	OAS4025GC - 06130
81937	40	25	150	330	50	25	25	280	G 1/4"	20	50	25	OAS4025GC - 06130
81938	40	25	200	380	50	25	25	330	G 1/4"	20	50	25	OAS4025GC - 06130
81939	40	25	250	430	50	25	25	380	G 1/4"	20	50	25	OAS4025GC - 06130
81940	40	25	300	480	50	25	25	430	G 1/4"	20	50	25	OAS4025GC - 06130
81941	40	25	350	530	50	25	25	480	G 1/4"	20	50	25	OAS4025GC - 06130
81942	40	25	400	580	50	25	25	530	G 1/4"	20	50	25	OAS4025GC - 06130
81943	40	25	450	630	50	25	25	580	G 1/4"	20	50	25	OAS4025GC - 06130
81944	40	25	500	680	50	25	25	630	G 1/4"	20	50	25	OAS4025GC - 06130
81945	40	25	550	730	50	25	25	680	G 1/4"	20	50	25	OAS4025GC - 06130
81946	40	25	600	780	50	25	25	730	G 1/4"	20	50	25	OAS4025GC - 06130
81947	40	25	650	830	50	25	25	780	G 1/4"	20	50	25	OAS4025GC - 06130
81948	40	25	700	880	50	25	25	830	G 1/4"	20	50	25	OAS4025GC - 06130
81949	40	25	750	930	50	25	25	880	G 1/4"	20	50	25	OAS4025GC - 06130
81950	40	25	800	980	50	25	25	930	G 1/4"	20	50	25	OAS4025GC - 06130
81951	40	25	850	1030	50	25	25	980	G 1/4"	20	50	25	OAS4025GC - 06130
81952	40	25	900	1080	50	25	25	1030	G 1/4"	20	50	25	OAS4025GC - 06130
81953	40	25	950	1130	50	25	25	1080	G 1/4"	20	50	25	OAS4025GC - 06130
81954	40	25	1000	1180	50	25	25	1130	G 1/4"	20	50	25	OAS4025GC - 06130

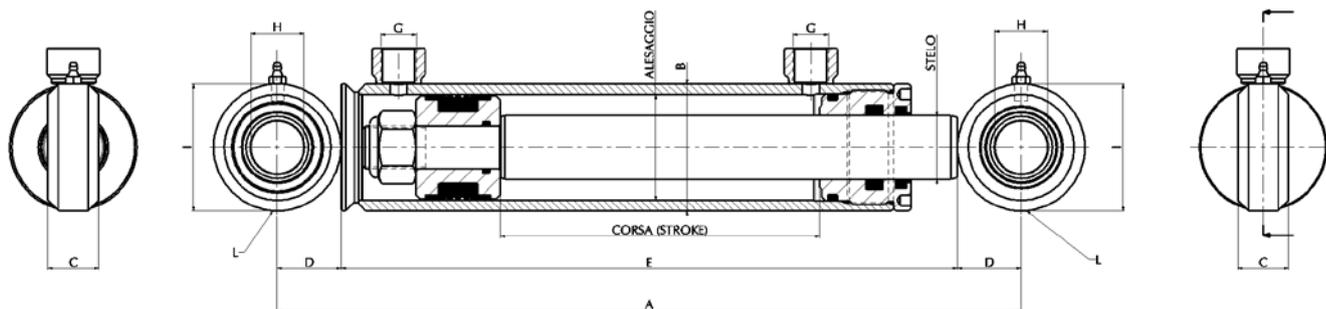

Art./Ref.	Alesaggio/ Bore	Stelo Ø/Rod Ø	Corsa/Stroke	Misura A mm/A size mm	Misura B mm/B size mm	Misura C mm/C size mm	Misura D mm/D size mm	Misura E mm/E size mm	Misura G mm/G size mm	Misura H mm/H size mm	Misura I mm/I size mm	Misura L mm/L size mm	Kit testa-kit pistone/ Rod guide kit-piston kit
81955	50	25	100	290	60	24	30	240	G 3/8"	25	60	30	OAS5025GC- 06132
81956	50	25	150	340	60	24	30	290	G 3/8"	25	60	30	OAS5025GC- 06132
81957	50	25	200	390	60	24	30	340	G 3/8"	25	60	30	OAS5025GC- 06132
81958	50	25	250	440	60	24	30	390	G 3/8"	25	60	30	OAS5025GC- 06132
81959	50	25	300	490	60	24	30	440	G 3/8"	25	60	30	OAS5025GC- 06132
81960	50	25	350	540	60	24	30	490	G 3/8"	25	60	30	OAS5025GC- 06132
81961	50	25	400	590	60	24	30	540	G 3/8"	25	60	30	OAS5025GC- 06132
81962	50	25	450	640	60	24	30	590	G 3/8"	25	60	30	OAS5025GC- 06132
81963	50	25	500	690	60	24	30	640	G 3/8"	25	60	30	OAS5025GC- 06132
81964	50	25	550	740	60	24	30	690	G 3/8"	25	60	30	OAS5025GC- 06132
81965	50	25	600	790	60	24	30	740	G 3/8"	25	60	30	OAS5025GC- 06132
81966	50	25	650	840	60	24	30	790	G 3/8"	25	60	30	OAS5025GC- 06132
81967	50	25	700	890	60	24	30	840	G 3/8"	25	60	30	OAS5025GC- 06132
81968	50	25	750	940	60	24	30	890	G 3/8"	25	60	30	OAS5025GC- 06132
81969	50	25	800	990	60	24	30	940	G 3/8"	25	60	30	OAS5025GC- 06132
81970	50	25	850	1040	60	24	30	990	G 3/8"	25	60	30	OAS5025GC- 06132
81971	50	25	900	1090	60	24	30	1040	G 3/8"	25	60	30	OAS5025GC- 06132
81972	50	25	950	1140	60	24	30	1090	G 3/8"	25	60	30	OAS5025GC- 06132
81973	50	25	1000	1190	60	24	30	1140	G 3/8"	25	60	30	OAS5025GC- 06132
81974	50	30	100	290	60	30	30	240	G 3/8"	25	60	30	OAS5030GC- 06132
81975	50	30	150	340	60	30	30	290	G 3/8"	25	60	30	OAS5030GC- 06132
81976	50	30	200	390	60	30	30	340	G 3/8"	25	60	30	OAS5030GC- 06132
81977	50	30	250	440	60	30	30	390	G 3/8"	25	60	30	OAS5030GC- 06132
81978	50	30	300	490	60	30	30	440	G 3/8"	25	60	30	OAS5030GC- 06132
81979	50	30	350	540	60	30	30	490	G 3/8"	25	60	30	OAS5030GC- 06132
81980	50	30	400	590	60	30	30	540	G 3/8"	25	60	30	OAS5030GC- 06132
81981	50	30	450	640	60	30	30	590	G 3/8"	25	60	30	OAS5030GC- 06132
81982	50	30	500	690	60	30	30	640	G 3/8"	25	60	30	OAS5030GC- 06132
81983	50	30	550	740	60	30	30	690	G 3/8"	25	60	30	OAS5030GC- 06132
81984	50	30	600	790	60	30	30	740	G 3/8"	25	60	30	OAS5030GC- 06132
81985	50	30	650	840	60	30	30	790	G 3/8"	25	60	30	OAS5030GC- 06132
81986	50	30	700	890	60	30	30	840	G 3/8"	25	60	30	OAS5030GC- 06132
81987	50	30	750	940	60	30	30	890	G 3/8"	25	60	30	OAS5030GC- 06132
81988	50	30	800	990	60	30	30	940	G 3/8"	25	60	30	OAS5030GC- 06132
81989	50	30	850	1040	60	30	30	990	G 3/8"	25	60	30	OAS5030GC- 06132
81990	50	30	900	1090	60	30	30	1040	G 3/8"	25	60	30	OAS5030GC- 06132
81991	50	30	950	1140	60	30	30	1090	G 3/8"	25	60	30	OAS5030GC- 06132
81992	50	30	1000	1190	60	30	30	1140	G 3/8"	25	60	30	OAS5030GC- 06132
81993	60	30	100	330	70	30	30	260	G 3/8"	30	66	30	OAS6030GC- 06133
81994	60	30	150	380	70	30	30	310	G 3/8"	30	66	30	OAS6030GC- 06133
81995	60	30	200	430	70	30	30	360	G 3/8"	30	66	30	OAS6030GC- 06133
81996	60	30	250	480	70	30	30	410	G 3/8"	30	66	30	OAS6030GC- 06133
81997	60	30	300	530	70	30	30	460	G 3/8"	30	66	30	OAS6030GC- 06133
81998	60	30	350	580	70	30	30	510	G 3/8"	30	66	30	OAS6030GC- 06133
81999	60	30	400	630	70	30	30	560	G 3/8"	30	66	30	OAS6030GC- 06133
82000	60	30	450	680	70	30	30	610	G 3/8"	30	66	30	OAS6030GC- 06133
82001	60	30	500	730	70	30	30	660	G 3/8"	30	66	30	OAS6030GC- 06133

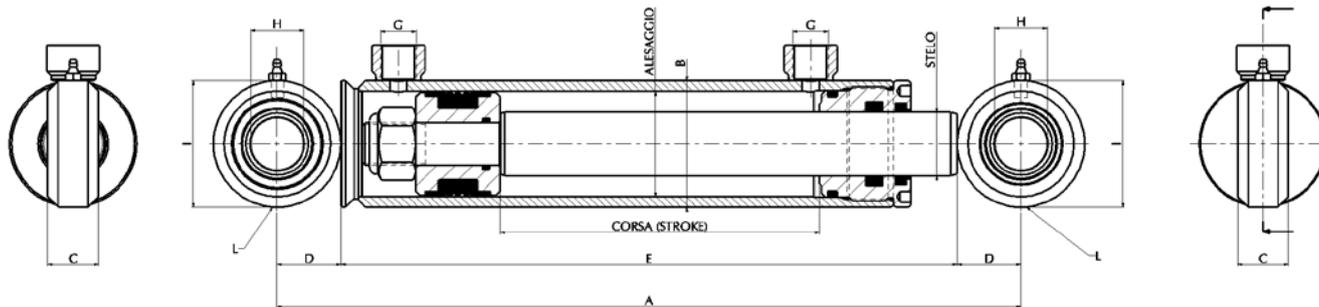

Art./Ref.	Alesaggio/ Bore	Stelo Ø/Rod Ø	Corsa/Stroke	Misura A mm/A size mm	Misura B mm/B size mm	Misura C mm/C size mm	Misura D mm/D size mm	Misura E mm/E size mm	Misura G mm/G size mm	Misura H mm/H size mm	Misura I mm/I size mm	Misura L mm/L size mm	Kit testa-kit pistone/ Rod guide kit-piston kit
81559	60	30	550	780	70	30	30	710	G 3/8"	30	66	30	0AS6030GC- 06133
82002	60	30	600	830	70	30	30	760	G 3/8"	30	66	30	0AS6030GC- 06133
82003	60	30	650	880	70	30	30	810	G 3/8"	30	66	30	0AS6030GC- 06133
82004	60	30	700	930	70	30	30	860	G 3/8"	30	66	30	0AS6030GC- 06133
82005	60	30	750	980	70	30	30	910	G 3/8"	30	66	30	0AS6030GC- 06133
82006	60	30	800	1030	70	30	30	960	G 3/8"	30	66	30	0AS6030GC- 06133
82007	60	30	850	1080	70	30	30	1010	G 3/8"	30	66	30	0AS6030GC- 06133
82008	60	30	900	1130	70	30	30	1060	G 3/8"	30	66	30	0AS6030GC- 06133
82009	60	30	950	1180	70	30	30	1110	G 3/8"	30	66	30	0AS6030GC- 06133
82010	60	30	1000	1230	70	30	30	1160	G 3/8"	30	66	30	0AS6030GC- 06133
82011	60	35	100	330	70	30	30	260	G 3/8"	30	66	30	0AS6035GC- 06133
82012	60	35	150	380	70	30	30	310	G 3/8"	30	66	30	0AS6035GC- 06133
82013	60	35	200	430	70	30	30	360	G 3/8"	30	66	30	0AS6035GC- 06133
82014	60	35	250	480	70	30	30	410	G 3/8"	30	66	30	0AS6035GC- 06133
82015	60	35	300	530	70	30	30	460	G 3/8"	30	66	30	0AS6035GC- 06133
82016	60	35	350	580	70	30	30	510	G 3/8"	30	66	30	0AS6035GC- 06133
82017	60	35	400	630	70	30	30	560	G 3/8"	30	66	30	0AS6035GC- 06133
82018	60	35	450	680	70	30	30	610	G 3/8"	30	66	30	0AS6035GC- 06133
82019	60	35	500	730	70	30	30	660	G 3/8"	30	66	30	0AS6035GC- 06133
82020	60	35	550	780	70	30	30	710	G 3/8"	30	66	30	0AS6035GC- 06133
82021	60	35	600	830	70	30	30	760	G 3/8"	30	66	30	0AS6035GC- 06133
82022	60	35	650	880	70	30	30	810	G 3/8"	30	66	30	0AS6035GC- 06133
82023	60	35	700	930	70	30	30	860	G 3/8"	30	66	30	0AS6035GC- 06133
82024	60	35	750	980	70	30	30	910	G 3/8"	30	66	30	0AS6035GC- 06133
82025	60	35	800	1030	70	30	30	960	G 3/8"	30	66	30	0AS6035GC- 06133
82026	60	35	850	1080	70	30	30	1010	G 3/8"	30	66	30	0AS6035GC- 06133
82027	60	35	900	1130	70	30	30	1060	G 3/8"	30	66	30	0AS6035GC- 06133
82028	60	35	950	1180	70	30	30	1110	G 3/8"	30	66	30	0AS6035GC- 06133
82029	60	35	1000	1230	70	30	30	1160	G 3/8"	30	66	30	0AS6035GC- 06133
82030	60	40	100	330	70	30	30	260	G 3/8"	30	66	30	0AS6040GC - 18219
82031	60	40	150	380	70	30	30	310	G 3/8"	30	66	30	0AS6040GC - 18219
82032	60	40	200	430	70	30	30	360	G 3/8"	30	66	30	0AS6040GC - 18219
82033	60	40	250	480	70	30	30	410	G 3/8"	30	66	30	0AS6040GC - 18219
82034	60	40	300	530	70	30	30	460	G 3/8"	30	66	30	0AS6040GC - 18219
82035	60	40	350	580	70	30	30	510	G 3/8"	30	66	30	0AS6040GC - 18219
82036	60	40	400	630	70	30	30	560	G 3/8"	30	66	30	0AS6040GC - 18219
82037	60	40	450	680	70	30	30	610	G 3/8"	30	66	30	0AS6040GC - 18219
82038	60	40	500	730	70	30	30	660	G 3/8"	30	66	30	0AS6040GC - 18219
82039	60	40	550	780	70	30	30	710	G 3/8"	30	66	30	0AS6040GC - 18219
82040	60	40	600	830	70	30	30	760	G 3/8"	30	66	30	0AS6040GC - 18219
82041	60	40	650	880	70	30	30	810	G 3/8"	30	66	30	0AS6040GC - 18219
82042	60	40	700	930	70	30	30	860	G 3/8"	30	66	30	0AS6040GC - 18219
82043	60	40	750	980	70	30	30	910	G 3/8"	30	66	30	0AS6040GC - 18219
82044	60	40	800	1030	70	30	30	960	G 3/8"	30	66	30	0AS6040GC - 18219
82045	60	40	850	1080	70	30	30	1010	G 3/8"	30	66	30	0AS6040GC - 18219
82046	60	40	900	1130	70	30	30	1060	G 3/8"	30	66	30	0AS6040GC - 18219
82047	60	40	950	1180	70	30	30	1110	G 3/8"	30	66	30	0AS6040GC - 18219

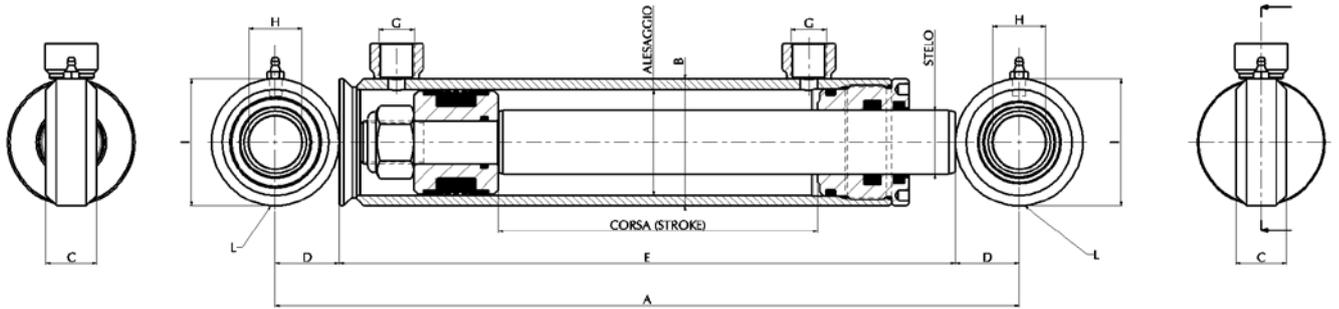

Art./Ref.	Alesaggio/ Bore	Stelo Ø/Rod Ø	Corsa/Stroke	Misura A mm/A size mm	Misura B mm/B size mm	Misura C mm/C size mm	Misura D mm/D size mm	Misura E mm/E size mm	Misura G mm/G size mm	Misura H mm/H size mm	Misura I mm/I size mm	Misura L mm/L size mm	Kit testa-kit pistone/ Rod guide kit-piston kit
82048	60	40	1000	1230	70	30	30	1160	G 3/8"	30	66	30	0AS6040GC - 18219
82049	70	35	100	335	80	35	40	260	G 3/8"	35	80	30	0AS7035GC - 06135
82050	70	35	150	385	80	35	40	310	G 3/8"	35	80	30	0AS7035GC - 06135
82051	70	35	200	435	80	35	40	360	G 3/8"	35	80	30	0AS7035GC - 06135
82052	70	35	250	485	80	35	40	410	G 3/8"	35	80	30	0AS7035GC - 06135
82053	70	35	300	535	80	35	40	460	G 3/8"	35	80	30	0AS7035GC - 06135
82054	70	35	350	585	80	35	40	510	G 3/8"	35	80	30	0AS7035GC - 06135
82055	70	35	400	635	80	35	40	560	G 3/8"	35	80	30	0AS7035GC - 06135
82056	70	35	450	685	80	35	40	610	G 3/8"	35	80	30	0AS7035GC - 06135
82057	70	35	500	735	80	35	40	660	G 3/8"	35	80	30	0AS7035GC - 06135
82058	70	35	550	785	80	35	40	710	G 3/8"	35	80	30	0AS7035GC - 06135
82059	70	35	600	835	80	35	40	760	G 3/8"	35	80	30	0AS7035GC - 06135
82060	70	35	650	885	80	35	40	810	G 3/8"	35	80	30	0AS7035GC - 06135
82061	70	35	700	935	80	35	40	860	G 3/8"	35	80	30	0AS7035GC - 06135
82062	70	35	750	985	80	35	40	910	G 3/8"	35	80	30	0AS7035GC - 06135
82063	70	35	800	1035	80	35	40	960	G 3/8"	35	80	30	0AS7035GC - 06135
82064	70	35	850	1085	80	35	40	1010	G 3/8"	35	80	30	0AS7035GC - 06135
82065	70	35	900	1135	80	35	40	1060	G 3/8"	35	80	30	0AS7035GC - 06135
82066	70	35	950	1185	80	35	40	1110	G 3/8"	35	80	30	0AS7035GC - 06135
82067	70	35	1000	1235	80	35	40	1160	G 3/8"	35	80	30	0AS7035GC - 06135
82068	70	40	100	335	80	35	40	260	G 3/8"	35	80	30	0AS7040GC - 06135
82069	70	40	150	385	80	35	40	310	G 3/8"	35	80	30	0AS7040GC - 06135
82070	70	40	200	435	80	35	40	360	G 3/8"	35	80	30	0AS7040GC - 06135
82071	70	40	250	485	80	35	40	410	G 3/8"	35	80	30	0AS7040GC - 06135
82072	70	40	300	535	80	35	40	460	G 3/8"	35	80	30	0AS7040GC - 06135
82073	70	40	350	585	80	35	40	510	G 3/8"	35	80	30	0AS7040GC - 06135
82074	70	40	400	635	80	35	40	560	G 3/8"	35	80	30	0AS7040GC - 06135
82075	70	40	450	685	80	35	40	610	G 3/8"	35	80	30	0AS7040GC - 06135
82076	70	40	500	735	80	35	40	660	G 3/8"	35	80	30	0AS7040GC - 06135
82077	70	40	550	785	80	35	40	710	G 3/8"	35	80	30	0AS7040GC - 06135
82078	70	40	600	835	80	35	40	760	G 3/8"	35	80	30	0AS7040GC - 06135
82079	70	40	650	885	80	35	40	810	G 3/8"	35	80	30	0AS7040GC - 06135
82080	70	40	700	935	80	35	40	860	G 3/8"	35	80	30	0AS7040GC - 06135
82081	70	40	750	985	80	35	40	910	G 3/8"	35	80	30	0AS7040GC - 06135
82082	70	40	800	1035	80	35	40	960	G 3/8"	35	80	30	0AS7040GC - 06135
82083	70	40	850	1085	80	35	40	1010	G 3/8"	35	80	30	0AS7040GC - 06135
82084	70	40	900	1135	80	35	40	1060	G 3/8"	35	80	30	0AS7040GC - 06135
82085	70	40	950	1185	80	35	40	1110	G 3/8"	35	80	30	0AS7040GC - 06135
82086	70	40	1000	1235	80	35	40	1160	G 3/8"	35	80	30	0AS7040GC - 06135
82087	80	40	100	355	95	28	48	275	G 3/8"	40	96	30	0AS8040GC - 06136
82088	80	40	150	405	95	28	48	325	G 3/8"	40	96	30	0AS8040GC - 06136
82089	80	40	200	455	95	28	48	375	G 3/8"	40	96	30	0AS8040GC - 06136
82090	80	40	250	505	95	28	48	425	G 3/8"	40	96	30	0AS8040GC - 06136
82091	80	40	300	555	95	28	48	475	G 3/8"	40	96	30	0AS8040GC - 06136
82092	80	40	350	605	95	28	48	525	G 3/8"	40	96	30	0AS8040GC - 06136
82093	80	40	400	655	95	28	48	575	G 3/8"	40	96	30	0AS8040GC - 06136
82094	80	40	450	705	95	28	48	625	G 3/8"	40	96	30	0AS8040GC - 06136

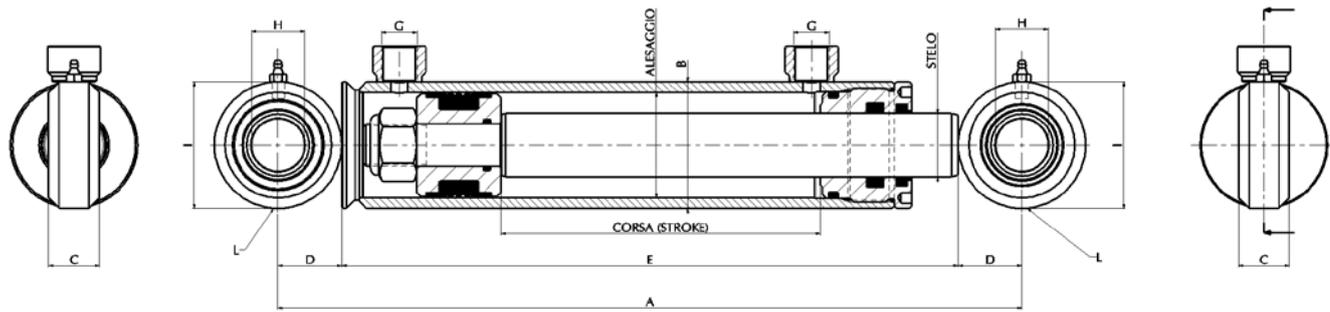

Art./Ref.	Alesaggio/ Bore	Stelo Ø/Rod Ø	Corsa/Stroke	Misura A mm/A size mm	Misura B mm/B size mm	Misura C mm/C size mm	Misura D mm/D size mm	Misura E mm/E size mm	Misura G mm/G size mm	Misura H mm/H size mm	Misura I mm/I size mm	Misura L mm/L size mm	Kit testa-kit pistone/ Rod guide kit-piston kit
82095	80	40	500	755	95	28	48	675	G 3/8"	40	96	30	OAS8040GC - 06136
82096	80	40	550	805	95	28	48	725	G 3/8"	40	96	30	OAS8040GC - 06136
82097	80	40	600	855	95	28	48	775	G 3/8"	40	96	30	OAS8040GC - 06136
82098	80	40	650	905	95	28	48	825	G 3/8"	40	96	30	OAS8040GC - 06136
82099	80	40	700	955	95	28	48	875	G 3/8"	40	96	30	OAS8040GC - 06136
82100	80	40	750	1005	95	28	48	925	G 3/8"	40	96	30	OAS8040GC - 06136
82101	80	40	800	1055	95	28	48	975	G 3/8"	40	96	30	OAS8040GC - 06136
82102	80	40	850	1105	95	28	48	1025	G 3/8"	40	96	30	OAS8040GC - 06136
82103	80	40	900	1155	95	28	48	1075	G 3/8"	40	96	30	OAS8040GC - 06136
82104	80	40	950	1205	95	28	48	1125	G 3/8"	40	96	30	OAS8040GC - 06136
82105	80	40	1000	1255	95	28	48	1175	G 3/8"	40	96	30	OAS8040GC - 06136
82106	80	50	100	355	95	28	48	275	G 3/8"	40	96	30	OAS8050GC - 06136
82107	80	50	150	405	95	28	48	325	G 3/8"	40	96	30	OAS8050GC - 06136
82108	80	50	200	455	95	28	48	375	G 3/8"	40	96	30	OAS8050GC - 06136
82109	80	50	250	505	95	28	48	425	G 3/8"	40	96	30	OAS8050GC - 06136
82110	80	50	300	555	95	28	48	475	G 3/8"	40	96	30	OAS8050GC - 06136
82111	80	50	350	605	95	28	48	525	G 3/8"	40	96	30	OAS8050GC - 06136
82112	80	50	400	655	95	28	48	575	G 3/8"	40	96	30	OAS8050GC - 06136
82113	80	50	450	705	95	28	48	625	G 3/8"	40	96	30	OAS8050GC - 06136
82114	80	50	500	755	95	28	48	675	G 3/8"	40	96	30	OAS8050GC - 06136
82115	80	50	550	805	95	28	48	725	G 3/8"	40	96	30	OAS8050GC - 06136
82116	80	50	600	855	95	28	48	775	G 3/8"	40	96	30	OAS8050GC - 06136
82117	80	50	650	905	95	28	48	825	G 3/8"	40	96	30	OAS8050GC - 06136
82118	80	50	700	955	95	28	48	875	G 3/8"	40	96	30	OAS8050GC - 06136
82119	80	50	750	1005	95	28	48	925	G 3/8"	40	96	30	OAS8050GC - 06136
82120	80	50	800	1055	95	28	48	975	G 3/8"	40	96	30	OAS8050GC - 06136
82121	80	50	850	1105	95	28	48	1025	G 3/8"	40	96	30	OAS8050GC - 06136
82122	80	50	900	1155	95	28	48	1075	G 3/8"	40	96	30	OAS8050GC - 06136
82123	80	50	950	1205	95	28	48	1125	G 3/8"	40	96	30	OAS8050GC - 06136
82124	80	50	1000	1255	95	28	48	1175	G 3/8"	40	96	30	OAS8050GC - 06136
82125	100	50	100	385	115	35	52,5	290	G 3/8"	50	105	30	OAS150GCA - 06138
82126	100	50	150	435	115	35	52,5	340	G 3/8"	50	105	30	OAS150GCA - 06138
82127	100	50	200	485	115	35	52,5	390	G 3/8"	50	105	30	OAS150GCA - 06138
82128	100	50	250	535	115	35	52,5	440	G 3/8"	50	105	30	OAS150GCA - 06138
82129	100	50	300	585	115	35	52,5	490	G 3/8"	50	105	30	OAS150GCA - 06138
82130	100	50	350	635	115	35	52,5	540	G 3/8"	50	105	30	OAS150GCA - 06138
82131	100	50	400	685	115	35	52,5	590	G 3/8"	50	105	30	OAS150GCA - 06138
82132	100	50	450	735	115	35	52,5	640	G 3/8"	50	105	30	OAS150GCA - 06138
82133	100	50	500	785	115	35	52,5	690	G 3/8"	50	105	30	OAS150GCA - 06138
82134	100	50	550	835	115	35	52,5	740	G 3/8"	50	105	30	OAS150GCA - 06138
82135	100	50	600	885	115	35	52,5	790	G 3/8"	50	105	30	OAS150GCA - 06138
82136	100	50	650	935	115	35	52,5	840	G 3/8"	50	105	30	OAS150GCA - 06138
82137	100	50	700	985	115	35	52,5	890	G 3/8"	50	105	30	OAS150GCA - 06138
82138	100	50	750	1035	115	35	52,5	940	G 3/8"	50	105	30	OAS150GCA - 06138
82139	100	50	800	1085	115	35	52,5	990	G 3/8"	50	105	30	OAS150GCA - 06138
82140	100	50	850	1135	115	35	52,5	1040	G 3/8"	50	105	30	OAS150GCA - 06138
82141	100	50	900	1185	115	35	52,5	1090	G 3/8"	50	105	30	OAS150GCA - 06138

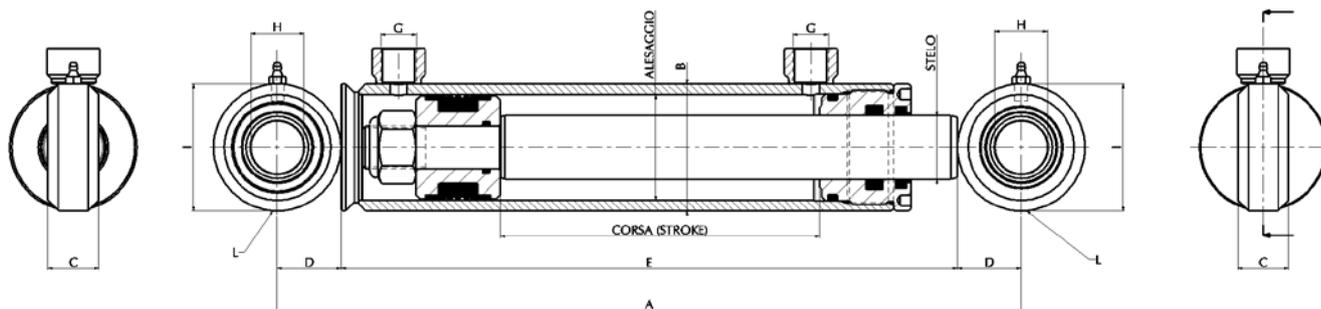

Art./Ref.	Alesaggio/ Bore	Stelo Ø/Rod Ø	Corsa/Stroke	Misura A mm/A size mm	Misura B mm/B size mm	Misura C mm/C size mm	Misura D mm/D size mm	Misura E mm/E size mm	Misura G mm/G size mm	Misura H mm/H size mm	Misura I mm/I size mm	Misura L mm/L size mm	Kit testa-kit pistone/ Rod guide kit-piston kit
82142	100	50	950	1235	115	35	52,5	1140	G 3/8"	50	105	30	0AS150GCA - 06138
82143	100	50	1000	1285	115	35	52,5	1190	G 3/8"	50	105	30	0AS150GCA - 06138
82144	100	60	100	385	115	35	52,5	290	G 3/8"	50	105	30	0AS150GCA - 06138
82145	100	60	150	435	115	35	52,5	340	G 3/8"	50	105	30	0AS160GCA - 06138
82146	100	60	200	485	115	35	52,5	390	G 3/8"	50	105	30	0AS160GCA - 06138
82147	100	60	250	535	115	35	52,5	440	G 3/8"	50	105	30	0AS160GCA - 06138
82148	100	60	300	585	115	35	52,5	490	G 3/8"	50	105	30	0AS160GCA - 06138
82149	100	60	350	635	115	35	52,5	540	G 3/8"	50	105	30	0AS160GCA - 06138
82150	100	60	400	685	115	35	52,5	590	G 3/8"	50	105	30	0AS160GCA - 06138
82151	100	60	450	735	115	35	52,5	640	G 3/8"	50	105	30	0AS160GCA - 06138
82152	100	60	500	785	115	35	52,5	690	G 3/8"	50	105	30	0AS160GCA - 06138
82153	100	60	550	835	115	35	52,5	740	G 3/8"	50	105	30	0AS160GCA - 06138
82154	100	60	600	885	115	35	52,5	790	G 3/8"	50	105	30	0AS160GCA - 06138
82155	100	60	650	935	115	35	52,5	840	G 3/8"	50	105	30	0AS160GCA - 06138
82156	100	60	700	985	115	35	52,5	890	G 3/8"	50	105	30	0AS160GCA - 06138
82157	100	60	750	1035	115	35	52,5	940	G 3/8"	50	105	30	0AS160GCA - 06138
82158	100	60	800	1085	115	35	52,5	990	G 3/8"	50	105	30	0AS160GCA - 06138
82159	100	60	850	1135	115	35	52,5	1040	G 3/8"	50	105	30	0AS160GCA - 06138
82160	100	60	900	1185	115	35	52,5	1090	G 3/8"	50	105	30	0AS160GCA - 06138
82161	100	60	950	1235	115	35	52,5	1140	G 3/8"	50	105	30	0AS160GCA - 06138
82162	100	60	1000	1285	115	35	52,5	1190	G 3/8"	50	105	30	0AS160GCA - 06138

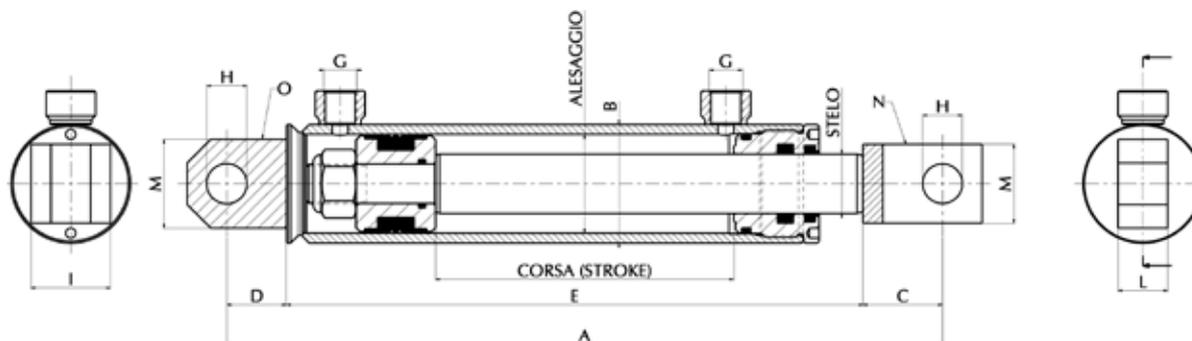
CILINDRI A DOPPIO EFFETTO CON FORCELLA
VERINS A DOUBLE EFFET AVEC CHAPE
HYDRAULIC CYLINDERS DOUBLE ACTING WITH FORK
HYDRAULISCHE ZYLINDER DOPPELWIRKEND MIT GABEL
CILINDROS DOBLE EFECTO CON HORQUILLA
ЦИЛИНДРЫ ДВОЙНОГО ДЕЙСТВИЯ С ВИЛКОЙ

Art./ Ref.	Alesag- gio/ Bore	Stelo Ø/ Rod Ø	Corsa/ Stroke	Misura A mm/A size mm	Misura B mm/B size mm	Misura C mm/C size mm	Misura D mm/D size mm	Misura E mm/E size mm	Misura G mm/G size mm	Misura H mm/H size mm	Misura I mm/I size mm	Misura L mm/L size mm	Misura M mm/M size mm	Misura N mm/N size mm	Misura O mm/O size mm	Kit testa-kit pistone/ Rod guide kit-piston kit
82163	40	20	50	239	50	34	25	180	G 1/4"	16	35	20	35	OFR16	OOF1625	OAS4020GC - 06130
82164	40	20	100	289	50	34	25	230	G 1/4"	16	35	20	35	OFR16	OOF1625	OAS4020GC - 06130
82165	40	20	150	339	50	34	25	280	G 1/4"	16	35	20	35	OFR16	OOF1625	OAS4020GC - 06130
82166	40	20	200	389	50	34	25	330	G 1/4"	16	35	20	35	OFR16	OOF1625	OAS4020GC - 06130
82167	40	20	250	439	50	34	25	380	G 1/4"	16	35	20	35	OFR16	OOF1625	OAS4020GC - 06130
82168	40	20	300	489	50	34	25	430	G 1/4"	16	35	20	35	OFR16	OOF1625	OAS4020GC - 06130
82169	40	20	350	539	50	34	25	480	G 1/4"	16	35	20	35	OFR16	OOF1625	OAS4020GC - 06130
82170	40	20	400	589	50	34	25	530	G 1/4"	16	35	20	35	OFR16	OOF1625	OAS4020GC - 06130
82171	40	20	450	639	50	34	25	580	G 1/4"	16	35	20	35	OFR16	OOF1625	OAS4020GC - 06130
82172	40	20	500	689	50	34	25	630	G 1/4"	16	35	20	35	OFR16	OOF1625	OAS4020GC - 06130
82173	40	20	550	739	50	34	25	680	G 1/4"	16	35	20	35	OFR16	OOF1625	OAS4020GC - 06130
82174	40	20	600	789	50	34	25	730	G 1/4"	16	35	20	35	OFR16	OOF1625	OAS4020GC - 06130
82175	40	20	650	839	50	34	25	780	G 1/4"	16	35	20	35	OFR16	OOF1625	OAS4020GC - 06130
82176	40	20	700	889	50	34	25	830	G 1/4"	16	35	20	35	OFR16	OOF1625	OAS4020GC - 06130
82177	40	20	750	939	50	34	25	880	G 1/4"	16	35	20	35	OFR16	OOF1625	OAS4020GC - 06130
82178	40	20	800	989	50	34	25	930	G 1/4"	16	35	20	35	OFR16	OOF1625	OAS4020GC - 06130
82179	40	20	850	1039	50	34	25	980	G 1/4"	16	35	20	35	OFR16	OOF1625	OAS4020GC - 06130
82180	40	20	900	1089	50	34	25	1030	G 1/4"	16	35	20	35	OFR16	OOF1625	OAS4020GC - 06130
82181	40	20	950	1139	50	34	25	1080	G 1/4"	16	35	20	35	OFR16	OOF1625	OAS4020GC - 06130
82182	40	20	1000	1189	50	34	25	1130	G 1/4"	16	35	20	35	OFR16	OOF1625	OAS4020GC - 06130
82183	40	25	50	239	50	34	25	180	G 1/4"	16	35	20	35	OFR16	OOF1625	OAS4025GC - 06130
82184	40	25	100	289	50	34	25	230	G 1/4"	16	35	20	35	OFR16	OOF1625	OAS4025GC - 06130
82185	40	25	150	339	50	34	25	280	G 1/4"	16	35	20	35	OFR16	OOF1625	OAS4025GC - 06130
82186	40	25	200	389	50	34	25	330	G 1/4"	16	35	20	35	OFR16	OOF1625	OAS4025GC - 06130
82187	40	25	250	439	50	34	25	380	G 1/4"	16	35	20	35	OFR16	OOF1625	OAS4025GC - 06130
82188	40	25	300	489	50	34	25	430	G 1/4"	16	35	20	35	OFR16	OOF1625	OAS4025GC - 06130
82189	40	25	350	539	50	34	25	480	G 1/4"	16	35	20	35	OFR16	OOF1625	OAS4025GC - 06130
82190	40	25	400	589	50	34	25	530	G 1/4"	16	35	20	35	OFR16	OOF1625	OAS4025GC - 06130
82191	40	25	450	639	50	34	25	580	G 1/4"	16	35	20	35	OFR16	OOF1625	OAS4025GC - 06130
82192	40	25	500	689	50	34	25	630	G 1/4"	16	35	20	35	OFR16	OOF1625	OAS4025GC - 06130
82193	40	25	550	739	50	34	25	680	G 1/4"	16	35	20	35	OFR16	OOF1625	OAS4025GC - 06130
82194	40	25	600	789	50	34	25	730	G 1/4"	16	35	20	35	OFR16	OOF1625	OAS4025GC - 06130
82195	40	25	650	839	50	34	25	780	G 1/4"	16	35	20	35	OFR16	OOF1625	OAS4025GC - 06130
82196	40	25	700	889	50	34	25	830	G 1/4"	16	35	20	35	OFR16	OOF1625	OAS4025GC - 06130
82197	40	25	750	939	50	34	25	880	G 1/4"	16	35	20	35	OFR16	OOF1625	OAS4025GC - 06130
82198	40	25	800	989	50	34	25	930	G 1/4"	16	35	20	35	OFR16	OOF1625	OAS4025GC - 06130
82199	40	25	850	1039	50	34	25	980	G 1/4"	16	35	20	35	OFR16	OOF1625	OAS4025GC - 06130
82200	40	25	900	1089	50	34	25	1030	G 1/4"	16	35	20	35	OFR16	OOF1625	OAS4025GC - 06130
82201	40	25	950	1139	50	34	25	1080	G 1/4"	16	35	20	35	OFR16	OOF1625	OAS4025GC - 06130
82202	50	25	1000	1189	50	34	25	1130	G 1/4"	16	35	20	35	OFR16	OOF1625	OAS4025GC - 06130
82203	50	25	100	310	60	40	30	240	G 3/8"	20	40	25	40	OFR20	OOF2030	OAS5025GC - 06132

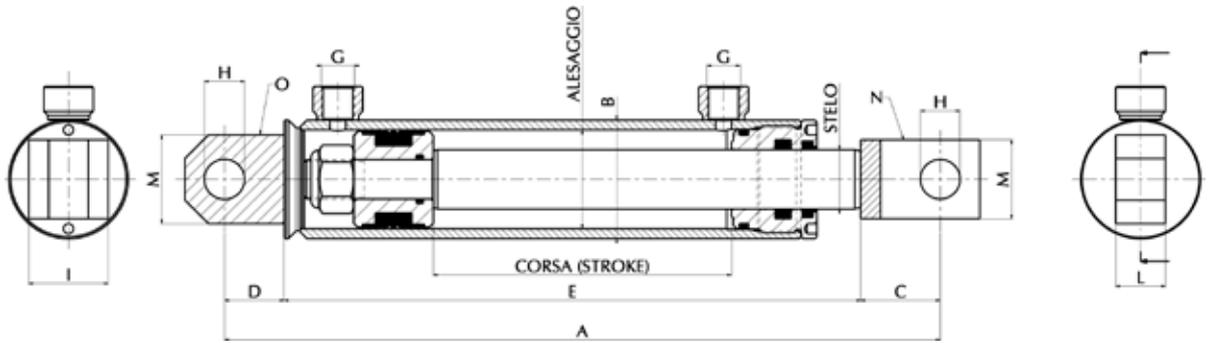

Art./ Ref.	Alesaggio/ Bore	Stelo Ø/ Rod Ø	Corsa/ Stroke	Misura A mm/A size mm	Misura B mm/B size mm	Misura C mm/C size mm	Misura D mm/D size mm	Misura E mm/E size mm	Misura G mm/G size mm	Misura H mm/H size mm	Misura I mm/I size mm	Misura L mm/L size mm	Misura M mm/M size mm	Misura N mm/N size mm	Misura O mm/O size mm	Kit testa-kit pistone/ Rod guide kit-piston kit
82204	50	25	150	360	60	40	30	290	G 3/8"	20	40	25	40	0FR20	00F2030	OAS5025GC- 06132
82205	50	25	200	410	60	40	30	340	G 3/8"	20	40	25	40	0FR20	00F2030	OAS5025GC- 06132
82206	50	25	250	460	60	40	30	390	G 3/8"	20	40	25	40	0FR20	00F2030	OAS5025GC- 06132
82207	50	25	300	510	60	40	30	440	G 3/8"	20	40	25	40	0FR20	00F2030	OAS5025GC- 06132
82208	50	25	350	560	60	40	30	490	G 3/8"	20	40	25	40	0FR20	00F2030	OAS5025GC- 06132
82209	50	25	400	610	60	40	30	540	G 3/8"	20	40	25	40	0FR20	00F2030	OAS5025GC- 06132
82210	50	25	450	660	60	40	30	590	G 3/8"	20	40	25	40	0FR20	00F2030	OAS5025GC- 06132
82211	50	25	500	710	60	40	30	640	G 3/8"	20	40	25	40	0FR20	00F2030	OAS5025GC- 06132
82212	50	25	550	760	60	40	30	690	G 3/8"	20	40	25	40	0FR20	00F2030	OAS5025GC- 06132
82213	50	25	600	810	60	40	30	740	G 3/8"	20	40	25	40	0FR20	00F2030	OAS5025GC- 06132
82214	50	25	650	860	60	40	30	790	G 3/8"	20	40	25	40	0FR20	00F2030	OAS5025GC- 06132
82215	50	25	700	910	60	40	30	840	G 3/8"	20	40	25	40	0FR20	00F2030	OAS5025GC- 06132
82216	50	25	750	960	60	40	30	890	G 3/8"	20	40	25	40	0FR20	00F2030	OAS5025GC- 06132
82217	50	25	800	1010	60	40	30	940	G 3/8"	20	40	25	40	0FR20	00F2030	OAS5025GC- 06132
82218	50	25	850	1060	60	40	30	990	G 3/8"	20	40	25	40	0FR20	00F2030	OAS5025GC- 06132
82219	50	25	900	1110	60	40	30	1040	G 3/8"	20	40	25	40	0FR20	00F2030	OAS5025GC- 06132
82220	50	25	950	1160	60	40	30	1090	G 3/8"	20	40	25	40	0FR20	00F2030	OAS5025GC- 06132
82221	50	25	1000	1210	60	40	30	1140	G 3/8"	20	40	25	40	0FR20	00F2030	OAS5025GC- 06132
82222	50	30	100	310	60	40	30	240	G 3/8"	20	40	25	40	0FR20	00F2030	OAS5025GC- 06132
82223	50	30	150	360	60	40	30	290	G 3/8"	20	40	25	40	0FR20	00F2030	OAS5030GC- 06132
82224	50	30	200	410	60	40	30	340	G 3/8"	20	40	25	40	0FR20	00F2030	OAS5030GC- 06132
82225	50	30	250	460	60	40	30	390	G 3/8"	20	40	25	40	0FR20	00F2030	OAS5030GC- 06132
82226	50	30	300	510	60	40	30	440	G 3/8"	20	40	25	40	0FR20	00F2030	OAS5030GC- 06132
82227	50	30	350	560	60	40	30	490	G 3/8"	20	40	25	40	0FR20	00F2030	OAS5030GC- 06132
82228	50	30	400	610	60	40	30	540	G 3/8"	20	40	25	40	0FR20	00F2030	OAS5030GC- 06132
82229	50	30	450	660	60	40	30	590	G 3/8"	20	40	25	40	0FR20	00F2030	OAS5030GC- 06132
82230	50	30	500	710	60	40	30	640	G 3/8"	20	40	25	40	0FR20	00F2030	OAS5030GC- 06132
82231	50	30	550	760	60	40	30	690	G 3/8"	20	40	25	40	0FR20	00F2030	OAS5030GC- 06132
82232	50	30	600	810	60	40	30	740	G 3/8"	20	40	25	40	0FR20	00F2030	OAS5030GC- 06132
82233	50	30	650	860	60	40	30	790	G 3/8"	20	40	25	40	0FR20	00F2030	OAS5030GC- 06132
82234	50	30	700	910	60	40	30	840	G 3/8"	20	40	25	40	0FR20	00F2030	OAS5030GC- 06132
82235	50	30	750	960	60	40	30	890	G 3/8"	20	40	25	40	0FR20	00F2030	OAS5030GC- 06132
82236	50	30	800	1010	60	40	30	940	G 3/8"	20	40	25	40	0FR20	00F2030	OAS5030GC- 06132
82237	50	30	850	1060	60	40	30	990	G 3/8"	20	40	25	40	0FR20	00F2030	OAS5030GC- 06132
82238	50	30	900	1110	60	40	30	1040	G 3/8"	20	40	25	40	0FR20	00F2030	OAS5030GC- 06132
82239	50	30	950	1160	60	40	30	1090	G 3/8"	20	40	25	40	0FR20	00F2030	OAS5030GC- 06132
82240	50	30	1000	1210	60	40	30	1140	G 3/8"	20	40	25	40	0FR20	00F2030	OAS5030GC- 06132
82241	60	30	100	340	70	45	35	260	G 3/8"	25	50	30	50	0FR25	00F2535	OAS6030GC- 06133
82242	60	30	150	390	70	45	35	310	G 3/8"	25	50	30	50	0FR25	00F2535	OAS6030GC- 06133
82243	60	30	200	440	70	45	35	360	G 3/8"	25	50	30	50	0FR25	00F2535	OAS6030GC- 06133
82244	60	30	250	490	70	45	35	410	G 3/8"	25	50	30	50	0FR25	00F2535	OAS6030GC- 06133
82245	60	30	300	540	70	45	35	460	G 3/8"	25	50	30	50	0FR25	00F2535	OAS6030GC- 06133
82246	60	30	350	590	70	45	35	510	G 3/8"	25	50	30	50	0FR25	00F2535	OAS6030GC- 06133
82247	60	30	400	640	70	45	35	560	G 3/8"	25	50	30	50	0FR25	00F2535	OAS6030GC- 06133
82248	60	30	450	690	70	45	35	610	G 3/8"	25	50	30	50	0FR25	00F2535	OAS6030GC- 06133
82249	60	30	500	740	70	45	35	660	G 3/8"	25	50	30	50	0FR25	00F2535	OAS6030GC- 06133
82250	60	30	550	790	70	45	35	710	G 3/8"	25	50	30	50	0FR25	00F2535	OAS6030GC- 06133
82251	60	30	600	840	70	45	35	760	G 3/8"	25	50	30	50	0FR25	00F2535	OAS6030GC- 06133

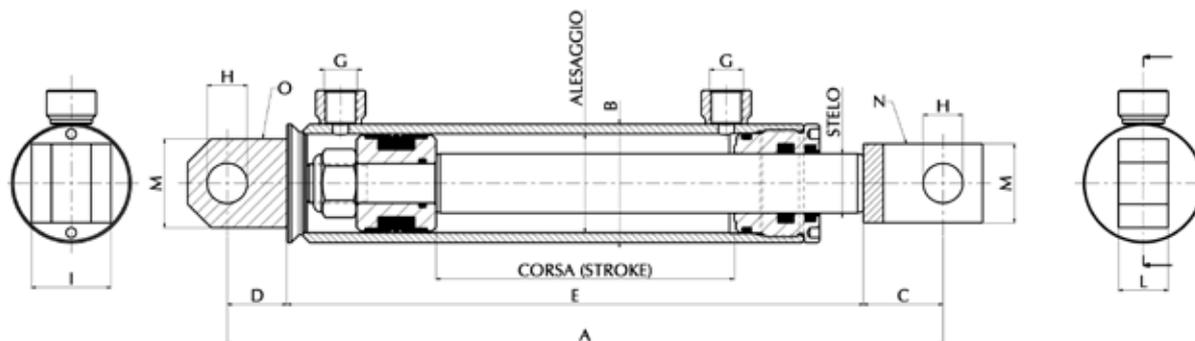

Art./ Ref.	Alesaggio/ Bore	Stelo Ø/ Rod Ø	Corsa/ Stroke	Misura A mm/A size mm	Misura B mm/B size mm	Misura C mm/C size mm	Misura D mm/D size mm	Misura E mm/E size mm	Misura G mm/G size mm	Misura H mm/H size mm	Misura I mm/I size mm	Misura L mm/L size mm	Misura M mm/M size mm	Misura N mm/N size mm	Misura O mm/O size mm	Kit testa-kit pistone/ Rod guide kit-piston kit
82252	60	30	650	890	70	45	35	810	G 3/8"	25	50	30	50	OFR25	OOF2535	OAS6030GC- 06133
82253	60	30	700	940	70	45	35	860	G 3/8"	25	50	30	50	OFR25	OOF2535	OAS6030GC- 06133
82254	60	30	750	990	70	45	35	910	G 3/8"	25	50	30	50	OFR25	OOF2535	OAS6030GC- 06133
82255	60	30	800	1040	70	45	35	960	G 3/8"	25	50	30	50	OFR25	OOF2535	OAS6030GC- 06133
82256	60	30	850	1090	70	45	35	1010	G 3/8"	25	50	30	50	OFR25	OOF2535	OAS6030GC- 06133
82257	60	30	900	1140	70	45	35	1060	G 3/8"	25	50	30	50	OFR25	OOF2535	OAS6030GC- 06133
82258	60	30	950	1190	70	45	35	1110	G 3/8"	25	50	30	50	OFR25	OOF2535	OAS6030GC- 06133
82259	60	30	1000	1240	70	45	35	1160	G 3/8"	25	50	30	50	OFR25	OOF2535	OAS6030GC- 06133
82260	60	35	100	340	70	45	35	260	G 3/8"	25	50	30	50	OFR25	OOF2535	OAS6035GC- 06133
82261	60	35	150	390	70	45	35	310	G 3/8"	25	50	30	50	OFR25	OOF2535	OAS6035GC- 06133
82262	60	35	200	440	70	45	35	360	G 3/8"	25	50	30	50	OFR25	OOF2535	OAS6035GC- 06133
82263	60	35	250	490	70	45	35	410	G 3/8"	25	50	30	50	OFR25	OOF2535	OAS6035GC- 06133
82264	60	35	300	540	70	45	35	460	G 3/8"	25	50	30	50	OFR25	OOF2535	OAS6035GC- 06133
82265	60	35	350	590	70	45	35	510	G 3/8"	25	50	30	50	OFR25	OOF2535	OAS6035GC- 06133
82266	60	35	400	640	70	45	35	560	G 3/8"	25	50	30	50	OFR25	OOF2535	OAS6035GC- 06133
82267	60	35	450	690	70	45	35	610	G 3/8"	25	50	30	50	OFR25	OOF2535	OAS6035GC- 06133
82268	60	35	500	740	70	45	35	660	G 3/8"	25	50	30	50	OFR25	OOF2535	OAS6035GC- 06133
82269	60	35	550	790	70	45	35	710	G 3/8"	25	50	30	50	OFR25	OOF2535	OAS6035GC- 06133
82270	60	35	600	840	70	45	35	760	G 3/8"	25	50	30	50	OFR25	OOF2535	OAS6035GC- 06133
82271	60	35	650	890	70	45	35	810	G 3/8"	25	50	30	50	OFR25	OOF2535	OAS6035GC- 06133
82272	60	35	700	940	70	45	35	860	G 3/8"	25	50	30	50	OFR25	OOF2535	OAS6035GC- 06133
82273	60	35	750	990	70	45	35	910	G 3/8"	25	50	30	50	OFR25	OOF2535	OAS6035GC- 06133
82274	60	35	800	1040	70	45	35	960	G 3/8"	25	50	30	50	OFR25	OOF2535	OAS6035GC- 06133
82275	60	35	850	1090	70	45	35	1010	G 3/8"	25	50	30	50	OFR25	OOF2535	OAS6035GC- 06133
82276	60	35	900	1140	70	45	35	1060	G 3/8"	25	50	30	50	OFR25	OOF2535	OAS6035GC- 06133
82277	60	35	950	1190	70	45	35	1110	G 3/8"	25	50	30	50	OFR25	OOF2535	OAS6035GC- 06133
82278	60	35	1000	1240	70	45	35	1160	G 3/8"	25	50	30	50	OFR25	OOF2535	OAS6035GC- 06133
82279	60	40	100	340	70	45	35	260	G 3/8"	25	50	30	50	OFR25	OOF2535	OAS6040GC- 18219
82280	60	40	150	390	70	45	35	310	G 3/8"	25	50	30	50	OFR25	OOF2535	OAS6040GC- 18219
82281	60	40	200	440	70	45	35	360	G 3/8"	25	50	30	50	OFR25	OOF2535	OAS6040GC- 18219
82282	60	40	250	490	70	45	35	410	G 3/8"	25	50	30	50	OFR25	OOF2535	OAS6040GC- 18219
82283	60	40	300	540	70	45	35	460	G 3/8"	25	50	30	50	OFR25	OOF2535	OAS6040GC- 18219
82284	60	40	350	590	70	45	35	510	G 3/8"	25	50	30	50	OFR25	OOF2535	OAS6040GC- 18219
82285	60	40	400	640	70	45	35	560	G 3/8"	25	50	30	50	OFR25	OOF2535	OAS6040GC- 18219
82286	60	40	450	690	70	45	35	610	G 3/8"	25	50	30	50	OFR25	OOF2535	OAS6040GC- 18219
82287	60	40	500	740	70	45	35	660	G 3/8"	25	50	30	50	OFR25	OOF2535	OAS6040GC- 18219
82288	60	40	550	790	70	45	35	710	G 3/8"	25	50	30	50	OFR25	OOF2535	OAS6040GC- 18219
82289	60	40	600	840	70	45	35	760	G 3/8"	25	50	30	50	OFR25	OOF2535	OAS6040GC- 18219
82290	60	40	650	890	70	45	35	810	G 3/8"	25	50	30	50	OFR25	OOF2535	OAS6040GC- 18219
82291	60	40	700	940	70	45	35	860	G 3/8"	25	50	30	50	OFR25	OOF2535	OAS6040GC- 18219
82292	60	40	750	990	70	45	35	910	G 3/8"	25	50	30	50	OFR25	OOF2535	OAS6040GC- 18219
82293	60	40	800	1040	70	45	35	960	G 3/8"	25	50	30	50	OFR25	OOF2535	OAS6040GC- 18219
82294	60	40	850	1090	70	45	35	1010	G 3/8"	25	50	30	50	OFR25	OOF2535	OAS6040GC- 18219
82295	60	40	900	1140	70	45	35	1060	G 3/8"	25	50	30	50	OFR25	OOF2535	OAS6040GC- 18219
82296	60	40	950	1190	70	45	35	1110	G 3/8"	25	50	30	50	OFR25	OOF2535	OAS6040GC- 18219
82297	60	40	1000	1240	70	45	35	1160	G 3/8"	25	50	30	50	OFR25	OOF2535	OAS6040GC- 18219
82298	70	35	100	340	80	45	35	260	G 3/8"	25	50	30	50	OFR25	OOF2535	OAS7035GC - 06135

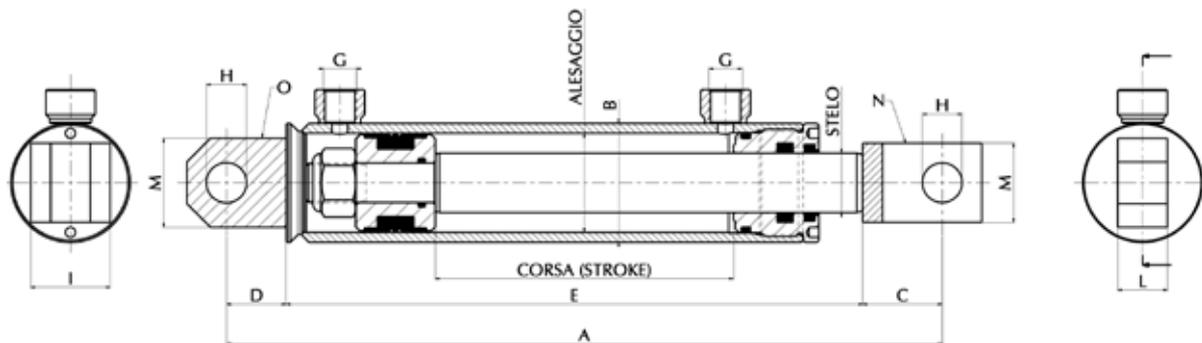

Art./ Ref.	Alesaggio/Bore	Stelo Ø/Rod Ø	Corsa/Stroke	Misura A mm/A size mm	Misura B mm/B size mm	Misura C mm/C size mm	Misura D mm/D size mm	Misura E mm/E size mm	Misura G mm/G size mm	Misura H mm/H size mm	Misura I mm/I size mm	Misura L mm/L size mm	Misura M mm/M size mm	Misura N mm/N size mm	Misura O mm/O size mm	Kit testa-kit pistone/Rod guide kit-piston kit
82299	70	35	150	390	80	45	35	310	G 3/8"	25	50	30	50	0FR25	00F2535	0AS7035GC - 06135
82300	70	35	200	440	80	45	35	360	G 3/8"	25	50	30	50	0FR25	00F2535	0AS7035GC - 06135
82301	70	35	250	490	80	45	35	410	G 3/8"	25	50	30	50	0FR25	00F2535	0AS7035GC - 06135
82302	70	35	300	540	80	45	35	460	G 3/8"	25	50	30	50	0FR25	00F2535	0AS7035GC - 06135
82303	70	35	350	590	80	45	35	510	G 3/8"	25	50	30	50	0FR25	00F2535	0AS7035GC - 06135
82304	70	35	400	640	80	45	35	560	G 3/8"	25	50	30	50	0FR25	00F2535	0AS7035GC - 06135
82305	70	35	450	690	80	45	35	610	G 3/8"	25	50	30	50	0FR25	00F2535	0AS7035GC - 06135
82306	70	35	500	740	80	45	35	660	G 3/8"	25	50	30	50	0FR25	00F2535	0AS7035GC - 06135
82307	70	35	550	790	80	45	35	710	G 3/8"	25	50	30	50	0FR25	00F2535	0AS7035GC - 06135
82308	70	35	600	840	80	45	35	760	G 3/8"	25	50	30	50	0FR25	00F2535	0AS7035GC - 06135
82309	70	35	650	890	80	45	35	810	G 3/8"	25	50	30	50	0FR25	00F2535	0AS7035GC - 06135
82310	70	35	700	940	80	45	35	860	G 3/8"	25	50	30	50	0FR25	00F2535	0AS7035GC - 06135
82311	70	35	750	990	80	45	35	910	G 3/8"	25	50	30	50	0FR25	00F2535	0AS7035GC - 06135
82312	70	35	800	1040	80	45	35	960	G 3/8"	25	50	30	50	0FR25	00F2535	0AS7035GC - 06135
82313	70	35	850	1090	80	45	35	1010	G 3/8"	25	50	30	50	0FR25	00F2535	0AS7035GC - 06135
82314	70	35	900	1140	80	45	35	1060	G 3/8"	25	50	30	50	0FR25	00F2535	0AS7035GC - 06135
82315	70	35	950	1190	80	45	35	1110	G 3/8"	25	50	30	50	0FR25	00F2535	0AS7035GC - 06135
82316	70	35	1000	1240	80	45	35	1160	G 3/8"	25	50	30	50	0FR25	00F2535	0AS7035GC - 06135
82317	70	40	100	340	80	45	35	260	G 3/8"	25	50	30	50	0FR25	00F2535	0AS7040GC - 06135
82318	70	40	150	390	80	45	35	310	G 3/8"	25	50	30	50	0FR25	00F2535	0AS7040GC - 06135
82319	70	40	200	440	80	45	35	360	G 3/8"	25	50	30	50	0FR25	00F2535	0AS7040GC - 06135
82320	70	40	250	490	80	45	35	410	G 3/8"	25	50	30	50	0FR25	00F2535	0AS7040GC - 06135
82321	70	40	300	540	80	45	35	460	G 3/8"	25	50	30	50	0FR25	00F2535	0AS7040GC - 06135
82322	70	40	350	590	80	45	35	510	G 3/8"	25	50	30	50	0FR25	00F2535	0AS7040GC - 06135
82323	70	40	400	640	80	45	35	560	G 3/8"	25	50	30	50	0FR25	00F2535	0AS7040GC - 06135
82324	70	40	450	690	80	45	35	610	G 3/8"	25	50	30	50	0FR25	00F2535	0AS7040GC - 06135
82325	70	40	500	740	80	45	35	660	G 3/8"	25	50	30	50	0FR25	00F2535	0AS7040GC - 06135
82326	70	40	550	790	80	45	35	710	G 3/8"	25	50	30	50	0FR25	00F2535	0AS7040GC - 06135
82327	70	40	600	840	80	45	35	760	G 3/8"	25	50	30	50	0FR25	00F2535	0AS7040GC - 06135
82328	70	40	650	890	80	45	35	810	G 3/8"	25	50	30	50	0FR25	00F2535	0AS7040GC - 06135
82329	70	40	700	940	80	45	35	860	G 3/8"	25	50	30	50	0FR25	00F2535	0AS7040GC - 06135
82330	70	40	750	990	80	45	35	910	G 3/8"	25	50	30	50	0FR25	00F2535	0AS7040GC - 06135
82331	70	40	800	1040	80	45	35	960	G 3/8"	25	50	30	50	0FR25	00F2535	0AS7040GC - 06135
82332	70	40	850	1090	80	45	35	1010	G 3/8"	25	50	30	50	0FR25	00F2535	0AS7040GC - 06135
82333	70	40	900	1140	80	45	35	1060	G 3/8"	25	50	30	50	0FR25	00F2535	0AS7040GC - 06135
82334	70	40	950	1190	80	45	35	1110	G 3/8"	25	50	30	50	0FR25	00F2535	0AS7040GC - 06135
82335	70	40	1000	1240	80	45	35	1160	G 3/8"	25	50	30	50	0FR25	00F2535	0AS7040GC - 06135

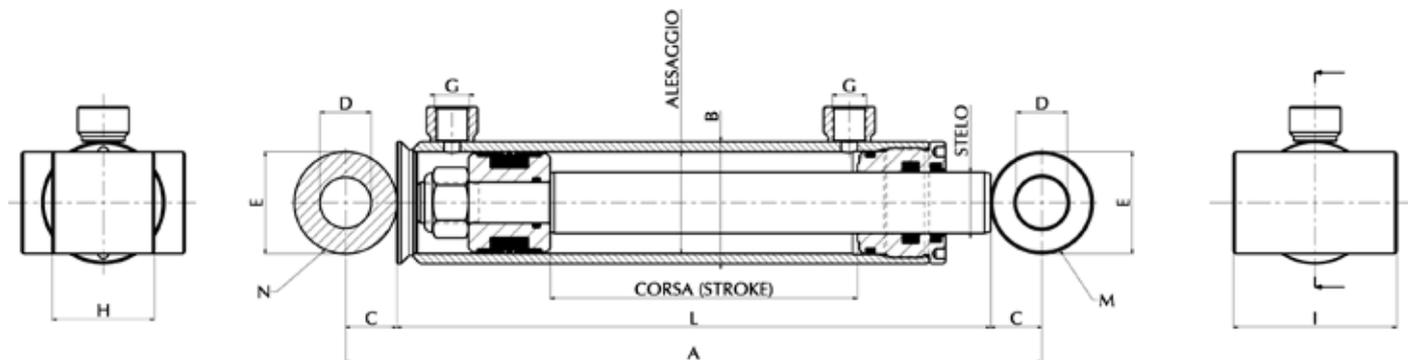
CILINDRI A DOPPIO EFFETTO CON BOCCOLE
VERINS A DOUBLE EFFET AVEC DOUILLES
HYDRAULIC CYLINDERS DOUBLE ACTING WITH BUSHINGS
HYDRAULISCHE ZYLINDER DOPPELWIRKEND MIT BUCHSEN
CILINDROS DOBLE EFECTO CON CASQUILLOS
ЦИЛИНДРЫ ДВОЙНОГО ДЕЙСТВИЯ С ВТУЛКАМИ

Art./ Ref.	Alesaggio/ Bore	Stelo Ø/ Rod Ø	Corsa/ Stroke	Misura A mm/A size mm	Misura B mm/B size mm	Misura C mm/C size mm	Misura D mm/D size mm	Misura E mm/E size mm	Misura G mm/G size mm	Misura H mm/H size mm	Misura I mm/I size mm	Misura L mm/L size mm	Misura M mm/M size mm	Misura N mm/N size mm	Kit testa-kit pistone/ Rod guide kit-piston kit
82412	40	20	50	215	50	17,5	16	35	G 1/4"	30	60	180	OBM1635	OBB1635	OAS4020GC - 06130
82413	40	20	100	265	50	17,5	16	35	G 1/4"	30	60	230	OBM1635	OBB1635	OAS4020GC - 06130
82414	40	20	150	315	50	17,5	16	35	G 1/4"	30	60	280	OBM1635	OBB1635	OAS4020GC - 06130
82415	40	20	200	365	50	17,5	16	35	G 1/4"	30	60	330	OBM1635	OBB1635	OAS4020GC - 06130
82416	40	20	250	415	50	17,5	16	35	G 1/4"	30	60	380	OBM1635	OBB1635	OAS4020GC - 06130
82417	40	20	300	465	50	17,5	16	35	G 1/4"	30	60	430	OBM1635	OBB1635	OAS4020GC - 06130
82418	40	20	350	515	50	17,5	16	35	G 1/4"	30	60	480	OBM1635	OBB1635	OAS4020GC - 06130
82419	40	20	400	565	50	17,5	16	35	G 1/4"	30	60	530	OBM1635	OBB1635	OAS4020GC - 06130
82420	40	20	450	615	50	17,5	16	35	G 1/4"	30	60	580	OBM1635	OBB1635	OAS4020GC - 06130
82421	40	20	500	665	50	17,5	16	35	G 1/4"	30	60	630	OBM1635	OBB1635	OAS4020GC - 06130
82422	40	20	550	715	50	17,5	16	35	G 1/4"	30	60	680	OBM1635	OBB1635	OAS4020GC - 06130
82423	40	20	600	765	50	17,5	16	35	G 1/4"	30	60	730	OBM1635	OBB1635	OAS4020GC - 06130
82424	40	20	650	815	50	17,5	16	35	G 1/4"	30	60	780	OBM1635	OBB1635	OAS4020GC - 06130
82425	40	20	700	865	50	17,5	16	35	G 1/4"	30	60	830	OBM1635	OBB1635	OAS4020GC - 06130
82426	40	20	750	915	50	17,5	16	35	G 1/4"	30	60	880	OBM1635	OBB1635	OAS4020GC - 06130
82427	40	20	800	965	50	17,5	16	35	G 1/4"	30	60	930	OBM1635	OBB1635	OAS4020GC - 06130
82428	40	20	850	1015	50	17,5	16	35	G 1/4"	30	60	980	OBM1635	OBB1635	OAS4020GC - 06130
82429	40	20	900	1065	50	17,5	16	35	G 1/4"	30	60	1030	OBM1635	OBB1635	OAS4020GC - 06130
82430	40	20	950	1115	50	17,5	16	35	G 1/4"	30	60	1080	OBM1635	OBB1635	OAS4020GC - 06130
82431	40	20	1000	1165	50	17,5	16	35	G 1/4"	30	60	1130	OBM1635	OBB1635	OAS4020GC - 06130
82432	40	25	50	215	50	17,5	16	35	G 1/4"	30	60	180	OBM1635	OBB1635	OAS4025GC - 06130
82433	40	25	100	265	50	17,5	16	35	G 1/4"	30	60	230	OBM1635	OBB1635	OAS4025GC - 06130
82434	40	25	150	315	50	17,5	16	35	G 1/4"	30	60	280	OBM1635	OBB1635	OAS4025GC - 06130
82435	40	25	200	365	50	17,5	16	35	G 1/4"	30	60	330	OBM1635	OBB1635	OAS4025GC - 06130
82436	40	25	250	415	50	17,5	16	35	G 1/4"	30	60	380	OBM1635	OBB1635	OAS4025GC - 06130
82437	40	25	300	465	50	17,5	16	35	G 1/4"	30	60	430	OBM1635	OBB1635	OAS4025GC - 06130
82438	40	25	350	515	50	17,5	16	35	G 1/4"	30	60	480	OBM1635	OBB1635	OAS4025GC - 06130
82439	40	25	400	565	50	17,5	16	35	G 1/4"	30	60	530	OBM1635	OBB1635	OAS4025GC - 06130
82440	40	25	450	615	50	17,5	16	35	G 1/4"	30	60	580	OBM1635	OBB1635	OAS4025GC - 06130
82441	40	25	500	665	50	17,5	16	35	G 1/4"	30	60	630	OBM1635	OBB1635	OAS4025GC - 06130
82442	40	25	550	715	50	17,5	16	35	G 1/4"	30	60	680	OBM1635	OBB1635	OAS4025GC - 06130
82443	40	25	600	765	50	17,5	16	35	G 1/4"	30	60	730	OBM1635	OBB1635	OAS4025GC - 06130
82444	40	25	650	815	50	17,5	16	35	G 1/4"	30	60	780	OBM1635	OBB1635	OAS4025GC - 06130
82445	40	25	700	865	50	17,5	16	35	G 1/4"	30	60	830	OBM1635	OBB1635	OAS4025GC - 06130
82446	40	25	750	915	50	17,5	16	35	G 1/4"	30	60	880	OBM1635	OBB1635	OAS4025GC - 06130
82447	40	25	800	965	50	17,5	16	35	G 1/4"	30	60	930	OBM1635	OBB1635	OAS4025GC - 06130
82448	40	25	850	1015	50	17,5	16	35	G 1/4"	30	60	980	OBM1635	OBB1635	OAS4025GC - 06130
82449	40	25	900	1065	50	17,5	16	35	G 1/4"	30	60	1030	OBM1635	OBB1635	OAS4025GC - 06130
82450	40	25	950	1115	50	17,5	16	35	G 1/4"	30	60	1080	OBM1635	OBB1635	OAS4025GC - 06130
82451	40	25	1000	1165	50	17,5	16	35	G 1/4"	30	60	1130	OBM1635	OBB1635	OAS4025GC - 06130

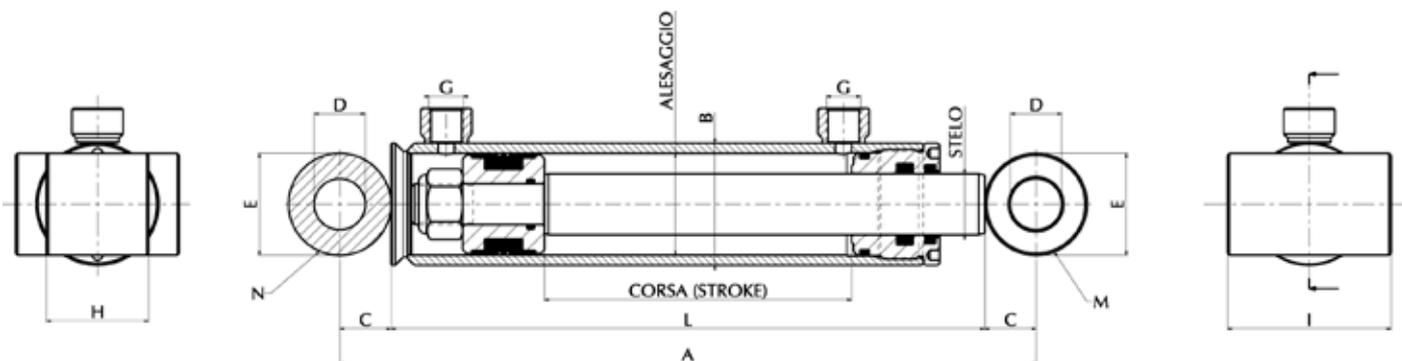

Art./ Ref.	Alesaggio/ Bore	Stelo Ø/ Rod Ø	Corsa/ Stroke	Misura A mm/A size mm	Misura B mm/B size mm	Misura C mm/C size mm	Misura D mm/D size mm	Misura E mm/E size mm	Misura G mm/G size mm	Misura H mm/H size mm	Misura I mm/I size mm	Misura L mm/L size mm	Misura M mm/M size mm	Misura N mm/N size mm	Kit testa-kit pistone/ Rod guide kit-piston kit
82452	50	25	100	280	60	20	20	35	G 3/8"	40	70	240	OBM2040	OBB2040	0AS5025GC- 06132
82453	50	25	150	330	60	20	20	35	G 3/8"	40	70	290	OBM2040	OBB2040	0AS5025GC- 06132
82454	50	25	200	380	60	20	20	35	G 3/8"	40	70	340	OBM2040	OBB2040	0AS5025GC- 06132
82455	50	25	250	430	60	20	20	35	G 3/8"	40	70	390	OBM2040	OBB2040	0AS5025GC- 06132
82456	50	25	300	480	60	20	20	35	G 3/8"	40	70	440	OBM2040	OBB2040	0AS5025GC- 06132
82457	50	25	350	530	60	20	20	35	G 3/8"	40	70	490	OBM2040	OBB2040	0AS5025GC- 06132
82458	50	25	400	580	60	20	20	35	G 3/8"	40	70	540	OBM2040	OBB2040	0AS5025GC- 06132
82459	50	25	450	630	60	20	20	35	G 3/8"	40	70	590	OBM2040	OBB2040	0AS5025GC- 06132
82460	50	25	500	680	60	20	20	35	G 3/8"	40	70	640	OBM2040	OBB2040	0AS5025GC- 06132
82461	50	25	550	730	60	20	20	35	G 3/8"	40	70	690	OBM2040	OBB2040	0AS5025GC- 06132
82462	50	25	600	780	60	20	20	35	G 3/8"	40	70	740	OBM2040	OBB2040	0AS5025GC- 06132
82463	50	25	650	830	60	20	20	35	G 3/8"	40	70	790	OBM2040	OBB2040	0AS5025GC- 06132
82464	50	25	700	880	60	20	20	35	G 3/8"	40	70	840	OBM2040	OBB2040	0AS5025GC- 06132
82465	50	25	750	930	60	20	20	35	G 3/8"	40	70	890	OBM2040	OBB2040	0AS5025GC- 06132
82466	50	25	800	980	60	20	20	35	G 3/8"	40	70	940	OBM2040	OBB2040	0AS5025GC- 06132
82467	50	25	850	1030	60	20	20	35	G 3/8"	40	70	990	OBM2040	OBB2040	0AS5025GC- 06132
82468	50	25	900	1080	60	20	20	35	G 3/8"	40	70	1040	OBM2040	OBB2040	0AS5025GC- 06132
82469	50	25	950	1130	60	20	20	35	G 3/8"	40	70	1090	OBM2040	OBB2040	0AS5025GC- 06132
82470	50	25	1000	1180	60	20	20	35	G 3/8"	40	70	1140	OBM2040	OBB2040	0AS5025GC- 06132
82471	50	30	100	290	60	25	25	50	G 3/8"	50	80	240	OBM2550	OBB2550	0AS5030GC- 06132
82472	50	30	150	340	60	25	25	50	G 3/8"	50	80	290	OBM2550	OBB2550	0AS5030GC- 06132
82473	50	30	200	390	60	25	25	50	G 3/8"	50	80	340	OBM2550	OBB2550	0AS5030GC- 06132
82474	50	30	250	440	60	25	25	50	G 3/8"	50	80	390	OBM2550	OBB2550	0AS5030GC- 06132
82475	50	30	300	490	60	25	25	50	G 3/8"	50	80	440	OBM2550	OBB2550	0AS5030GC- 06132
82476	50	30	350	540	60	25	25	50	G 3/8"	50	80	490	OBM2550	OBB2550	0AS5030GC- 06132
82477	50	30	400	590	60	25	25	50	G 3/8"	50	80	540	OBM2550	OBB2550	0AS5030GC- 06132
82478	50	30	450	640	60	25	25	50	G 3/8"	50	80	590	OBM2550	OBB2550	0AS5030GC- 06132
82479	50	30	500	690	60	25	25	50	G 3/8"	50	80	640	OBM2550	OBB2550	0AS5030GC- 06132
82480	50	30	550	740	60	25	25	50	G 3/8"	50	80	690	OBM2550	OBB2550	0AS5030GC- 06132
82481	50	30	600	790	60	25	25	50	G 3/8"	50	80	740	OBM2550	OBB2550	0AS5030GC- 06132
82482	50	30	650	840	60	25	25	50	G 3/8"	50	80	790	OBM2550	OBB2550	0AS5030GC- 06132
82483	50	30	700	890	60	25	25	50	G 3/8"	50	80	840	OBM2550	OBB2550	0AS5030GC- 06132
82484	50	30	750	940	60	25	25	50	G 3/8"	50	80	890	OBM2550	OBB2550	0AS5030GC- 06132
82485	50	30	800	990	60	25	25	50	G 3/8"	50	80	940	OBM2550	OBB2550	0AS5030GC- 06132
82486	50	30	850	1040	60	25	25	50	G 3/8"	50	80	990	OBM2550	OBB2550	0AS5030GC- 06132
82487	50	30	900	1090	60	25	25	50	G 3/8"	50	80	1040	OBM2550	OBB2550	0AS5030GC- 06132
82488	50	30	950	1140	60	25	25	50	G 3/8"	50	80	1090	OBM2550	OBB2550	0AS5030GC- 06132
82489	50	30	1000	1190	60	25	25	50	G 3/8"	50	80	1140	OBM2550	OBB2550	0AS5030GC- 06132
82490	60	30	100	310	70	25	25	50	G 3/8"	50	80	260	OBM2550	OBB2550	0AS6030GC- 06133
82491	60	30	150	360	70	25	25	50	G 3/8"	50	80	310	OBM2550	OBB2550	0AS6030GC- 06133
82492	60	30	200	410	70	25	25	50	G 3/8"	50	80	360	OBM2550	OBB2550	0AS6030GC- 06133
82493	60	30	250	460	70	25	25	50	G 3/8"	50	80	410	OBM2550	OBB2550	0AS6030GC- 06133
82494	60	30	300	510	70	25	25	50	G 3/8"	50	80	460	OBM2550	OBB2550	0AS6030GC- 06133
82495	60	30	350	560	70	25	25	50	G 3/8"	50	80	510	OBM2550	OBB2550	0AS6030GC- 06133
82496	60	30	400	610	70	25	25	50	G 3/8"	50	80	560	OBM2550	OBB2550	0AS6030GC- 06133
82497	60	30	450	660	70	25	25	50	G 3/8"	50	80	610	OBM2550	OBB2550	0AS6030GC- 06133
82498	60	30	500	710	70	25	25	50	G 3/8"	50	80	660	OBM2550	OBB2550	0AS6030GC- 06133

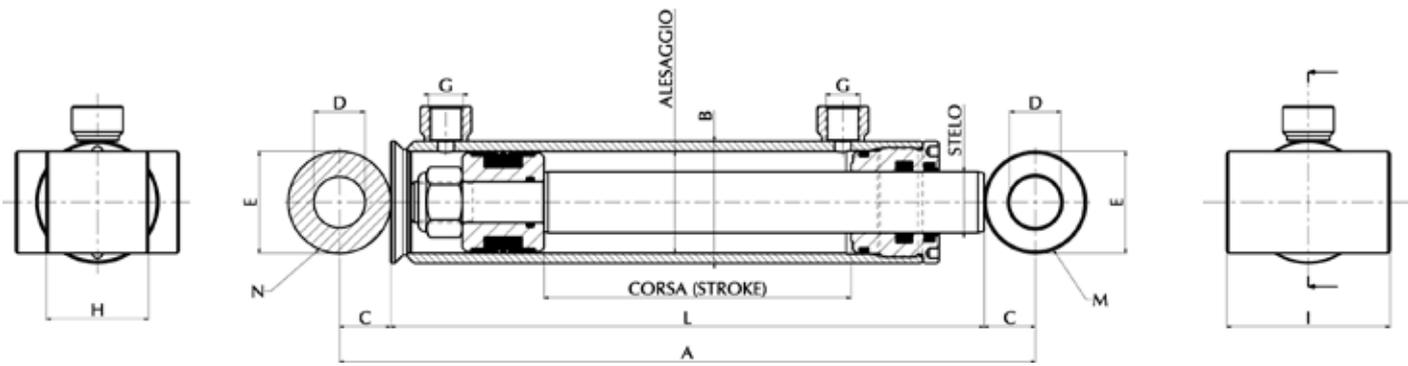

Art./ Ref.	Alesaggio/ Bore	Stelo Ø/ Rod Ø	Corsa/ Stroke	Misura A mm/A size mm	Misura B mm/B size mm	Misura C mm/C size mm	Misura D mm/D size mm	Misura E mm/E size mm	Misura G mm/G size mm	Misura H mm/H size mm	Misura I mm/I size mm	Misura L mm/L size mm	Misura M mm/M size mm	Misura N mm/N size mm	Kit testa-kit pistone/ Rod guide kit-piston kit
82499	60	30	550	760	70	25	25	50	G 3/8"	50	80	710	OBM2550	OBB2550	0AS6030GC - 06133
82500	60	30	600	810	70	25	25	50	G 3/8"	50	80	760	OBM2550	OBB2550	0AS6030GC - 06133
82501	60	30	650	860	70	25	25	50	G 3/8"	50	80	810	OBM2550	OBB2550	0AS6030GC - 06133
82502	60	30	700	910	70	25	25	50	G 3/8"	50	80	860	OBM2550	OBB2550	0AS6030GC - 06133
82503	60	30	750	960	70	25	25	50	G 3/8"	50	80	910	OBM2550	OBB2550	0AS6030GC - 06133
82504	60	30	800	1010	70	25	25	50	G 3/8"	50	80	960	OBM2550	OBB2550	0AS6030GC - 06133
82505	60	30	850	1060	70	25	25	50	G 3/8"	50	80	1010	OBM2550	OBB2550	0AS6030GC - 06133
82506	60	30	900	1110	70	25	25	50	G 3/8"	50	80	1060	OBM2550	OBB2550	0AS6030GC - 06133
82507	60	30	950	1160	70	25	25	50	G 3/8"	50	80	1110	OBM2550	OBB2550	0AS6030GC - 06133
82508	60	30	1000	1210	70	25	25	50	G 3/8"	50	80	1160	OBM2550	OBB2550	0AS6030GC - 06133
82509	60	35	100	310	70	25	25	50	G 3/8"	50	80	260	OBM2550	OBB2550	0AS6035GC - 06133
82510	60	35	150	360	70	25	25	50	G 3/8"	50	80	310	OBM2550	OBB2550	0AS6035GC - 06133
82511	60	35	200	410	70	25	25	50	G 3/8"	50	80	360	OBM2550	OBB2550	0AS6035GC - 06133
82512	60	35	250	460	70	25	25	50	G 3/8"	50	80	410	OBM2550	OBB2550	0AS6035GC - 06133
82513	60	35	300	510	70	25	25	50	G 3/8"	50	80	460	OBM2550	OBB2550	0AS6035GC - 06133
82514	60	35	350	560	70	25	25	50	G 3/8"	50	80	510	OBM2550	OBB2550	0AS6035GC - 06133
82515	60	35	400	610	70	25	25	50	G 3/8"	50	80	560	OBM2550	OBB2550	0AS6035GC - 06133
82516	60	35	450	660	70	25	25	50	G 3/8"	50	80	610	OBM2550	OBB2550	0AS6035GC - 06133
82517	60	35	500	710	70	25	25	50	G 3/8"	50	80	660	OBM2550	OBB2550	0AS6035GC - 06133
82518	60	35	550	760	70	25	25	50	G 3/8"	50	80	710	OBM2550	OBB2550	0AS6035GC - 06133
82519	60	35	600	810	70	25	25	50	G 3/8"	50	80	760	OBM2550	OBB2550	0AS6035GC - 06133
82520	60	35	650	860	70	25	25	50	G 3/8"	50	80	810	OBM2550	OBB2550	0AS6035GC - 06133
82521	60	35	700	910	70	25	25	50	G 3/8"	50	80	860	OBM2550	OBB2550	0AS6035GC - 06133
82522	60	35	750	960	70	25	25	50	G 3/8"	50	80	910	OBM2550	OBB2550	0AS6035GC - 06133
82523	60	35	800	1010	70	25	25	50	G 3/8"	50	80	960	OBM2550	OBB2550	0AS6035GC - 06133
82524	60	35	850	1060	70	25	25	50	G 3/8"	50	80	1010	OBM2550	OBB2550	0AS6035GC - 06133
82525	60	35	900	1110	70	25	25	50	G 3/8"	50	80	1060	OBM2550	OBB2550	0AS6035GC - 06133
82526	60	35	950	1160	70	25	25	50	G 3/8"	50	80	1110	OBM2550	OBB2550	0AS6035GC - 06133
82527	60	35	1000	1210	70	25	25	50	G 3/8"	50	80	1160	OBM2550	OBB2550	0AS6035GC - 06133
82528	60	40	100	310	70	25	25	50	G 3/8"	50	80	260	OBM2550	OBB2550	0AS6040GC - 18219
82529	60	40	150	360	70	25	25	50	G 3/8"	50	80	310	OBM2550	OBB2550	0AS6040GC - 18219
82530	60	40	200	410	70	25	25	50	G 3/8"	50	80	360	OBM2550	OBB2550	0AS6040GC - 18219
82531	60	40	250	460	70	25	25	50	G 3/8"	50	80	410	OBM2550	OBB2550	0AS6040GC - 18219
82532	60	40	300	510	70	25	25	50	G 3/8"	50	80	460	OBM2550	OBB2550	0AS6040GC - 18219
82533	60	40	350	560	70	25	25	50	G 3/8"	50	80	510	OBM2550	OBB2550	0AS6040GC - 18219
82534	60	40	400	610	70	25	25	50	G 3/8"	50	80	560	OBM2550	OBB2550	0AS6040GC - 18219
82535	60	40	450	660	70	25	25	50	G 3/8"	50	80	610	OBM2550	OBB2550	0AS6040GC - 18219
82536	60	40	500	710	70	25	25	50	G 3/8"	50	80	660	OBM2550	OBB2550	0AS6040GC - 18219
82537	60	40	550	760	70	25	25	50	G 3/8"	50	80	710	OBM2550	OBB2550	0AS6040GC - 18219
82538	60	40	600	810	70	25	25	50	G 3/8"	50	80	760	OBM2550	OBB2550	0AS6040GC - 18219
82539	60	40	650	860	70	25	25	50	G 3/8"	50	80	810	OBM2550	OBB2550	0AS6040GC - 18219
82540	60	40	700	910	70	25	25	50	G 3/8"	50	80	860	OBM2550	OBB2550	0AS6040GC - 18219
82541	60	40	750	960	70	25	25	50	G 3/8"	50	80	910	OBM2550	OBB2550	0AS6040GC - 18219
82542	60	40	800	1010	70	25	25	50	G 3/8"	50	80	960	OBM2550	OBB2550	0AS6040GC - 18219
82543	60	40	850	1060	70	25	25	50	G 3/8"	50	80	1010	OBM2550	OBB2550	0AS6040GC - 18219
82544	60	40	900	1110	70	25	25	50	G 3/8"	50	80	1060	OBM2550	OBB2550	0AS6040GC - 18219
82545	60	40	950	1160	70	25	25	50	G 3/8"	50	80	1110	OBM2550	OBB2550	0AS6040GC - 18219

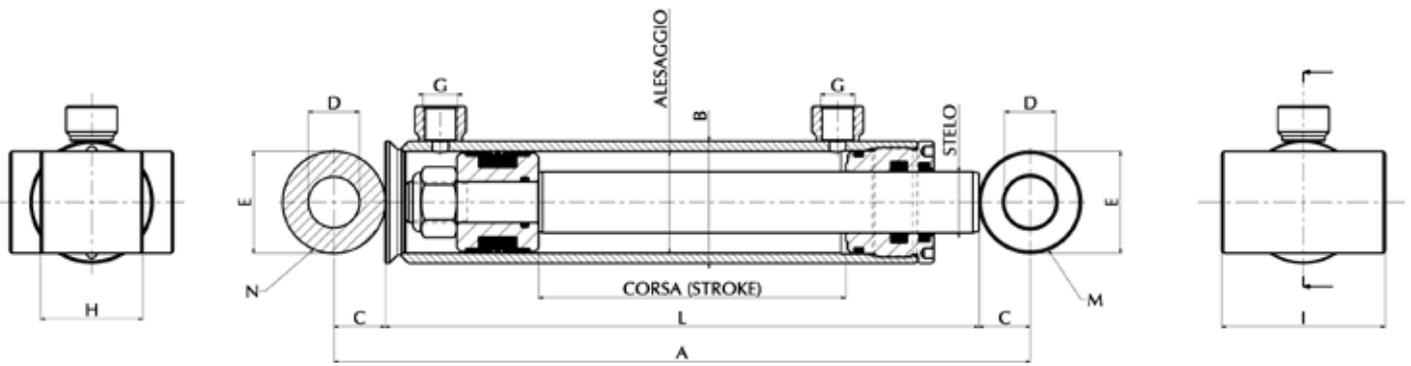

Art./ Ref.	Alesaggio/ Bore	Stelo Ø/ Rod Ø	Corsa/ Stroke	Misura A mm/A size mm	Misura B mm/B size mm	Misura C mm/C size mm	Misura D mm/D size mm	Misura E mm/E size mm	Misura G mm/G size mm	Misura H mm/H size mm	Misura I mm/I size mm	Misura L mm/L size mm	Misura M mm/M size mm	Misura N mm/N size mm	Kit testa-kit pistone/ Rod guide kit-piston kit
82546	60	40	1000	1210	70	25	25	50	G 3/8"	50	80	1160	OBM2550	OBB2550	0AS6040GC - 18219
82547	70	35	100	310	80	25	25	50	G 3/8"	50	90	260	OBM2550	OBB2550	0AS7035GC - 06135
82548	70	35	150	360	80	25	25	50	G 3/8"	50	90	310	OBM2550	OBB2550	0AS7035GC - 06135
82549	70	35	200	410	80	25	25	50	G 3/8"	50	90	360	OBM2550	OBB2550	0AS7035GC - 06135
82550	70	35	250	460	80	25	25	50	G 3/8"	50	90	410	OBM2550	OBB2550	0AS7035GC - 06135
82551	70	35	300	510	80	25	25	50	G 3/8"	50	90	460	OBM2550	OBB2550	0AS7035GC - 06135
82552	70	35	350	560	80	25	25	50	G 3/8"	50	90	510	OBM2550	OBB2550	0AS7035GC - 06135
82553	70	35	400	610	80	25	25	50	G 3/8"	50	90	560	OBM2550	OBB2550	0AS7035GC - 06135
82554	70	35	450	660	80	25	25	50	G 3/8"	50	90	610	OBM2550	OBB2550	0AS7035GC - 06135
82555	70	35	500	710	80	25	25	50	G 3/8"	50	90	660	OBM2550	OBB2550	0AS7035GC - 06135
82556	70	35	550	760	80	25	25	50	G 3/8"	50	90	710	OBM2550	OBB2550	0AS7035GC - 06135
82557	70	35	600	810	80	25	25	50	G 3/8"	50	90	760	OBM2550	OBB2550	0AS7035GC - 06135
82558	70	35	650	860	80	25	25	50	G 3/8"	50	90	810	OBM2550	OBB2550	0AS7035GC - 06135
82559	70	35	700	910	80	25	25	50	G 3/8"	50	90	860	OBM2550	OBB2550	0AS7035GC - 06135
82560	70	35	750	960	80	25	25	50	G 3/8"	50	90	910	OBM2550	OBB2550	0AS7035GC - 06135
82561	70	35	800	1010	80	25	25	50	G 3/8"	50	90	960	OBM2550	OBB2550	0AS7035GC - 06135
82562	70	35	850	1060	80	25	25	50	G 3/8"	50	90	1010	OBM2550	OBB2550	0AS7035GC - 06135
82563	70	35	900	1110	80	25	25	50	G 3/8"	50	90	1060	OBM2550	OBB2550	0AS7035GC - 06135
82564	70	35	950	1160	80	25	25	50	G 3/8"	50	90	1110	OBM2550	OBB2550	0AS7035GC - 06135
82565	70	35	1000	1210	80	25	25	50	G 3/8"	50	90	1160	OBM2550	OBB2550	0AS7035GC - 06135
82566	70	40	100	310	80	25	25	50	G 3/8"	50	90	260	OBM2550	OBB2550	0AS7040GC - 06135
82567	70	40	150	360	80	25	25	50	G 3/8"	50	90	310	OBM2550	OBB2550	0AS7040GC - 06135
82568	70	40	200	410	80	25	25	50	G 3/8"	50	90	360	OBM2550	OBB2550	0AS7040GC - 06135
82569	70	40	250	460	80	25	25	50	G 3/8"	50	90	410	OBM2550	OBB2550	0AS7040GC - 06135
82570	70	40	300	510	80	25	25	50	G 3/8"	50	90	460	OBM2550	OBB2550	0AS7040GC - 06135
82571	70	40	350	560	80	25	25	50	G 3/8"	50	90	510	OBM2550	OBB2550	0AS7040GC - 06135
82572	70	40	400	610	80	25	25	50	G 3/8"	50	90	560	OBM2550	OBB2550	0AS7040GC - 06135
82573	70	40	450	660	80	25	25	50	G 3/8"	50	90	610	OBM2550	OBB2550	0AS7040GC - 06135
82574	70	40	500	710	80	25	25	50	G 3/8"	50	90	660	OBM2550	OBB2550	0AS7040GC - 06135
82575	70	40	550	760	80	25	25	50	G 3/8"	50	90	710	OBM2550	OBB2550	0AS7040GC - 06135
82576	70	40	600	810	80	25	25	50	G 3/8"	50	90	760	OBM2550	OBB2550	0AS7040GC - 06135
82577	70	40	650	860	80	25	25	50	G 3/8"	50	90	810	OBM2550	OBB2550	0AS7040GC - 06135
82578	70	40	700	910	80	25	25	50	G 3/8"	50	90	860	OBM2550	OBB2550	0AS7040GC - 06135
82579	70	40	750	960	80	25	25	50	G 3/8"	50	90	910	OBM2550	OBB2550	0AS7040GC - 06135
82580	70	40	800	1010	80	25	25	50	G 3/8"	50	90	960	OBM2550	OBB2550	0AS7040GC - 06135
82581	70	40	850	1060	80	25	25	50	G 3/8"	50	90	1010	OBM2550	OBB2550	0AS7040GC - 06135
82582	70	40	900	1110	80	25	25	50	G 3/8"	50	90	1060	OBM2550	OBB2550	0AS7040GC - 06135
82583	70	40	950	1160	80	25	25	50	G 3/8"	50	90	1110	OBM2550	OBB2550	0AS7040GC - 06135
82584	70	40	1000	1210	80	25	25	50	G 3/8"	50	90	1160	OBM2550	OBB2550	0AS7040GC - 06135
82585	80	40	100	335	95	30	30	60	G 3/8"	60	110	275	OBM3060	OBB3060	0AS8040GC - 06136
82586	80	40	150	385	95	30	30	60	G 3/8"	60	110	325	OBM3060	OBB3060	0AS8040GC - 06136
82587	80	40	200	435	95	30	30	60	G 3/8"	60	110	375	OBM3060	OBB3060	0AS8040GC - 06136
82588	80	40	250	485	95	30	30	60	G 3/8"	60	110	425	OBM3060	OBB3060	0AS8040GC - 06136
82589	80	40	300	535	95	30	30	60	G 3/8"	60	110	475	OBM3060	OBB3060	0AS8040GC - 06136
82590	80	40	350	585	95	30	30	60	G 3/8"	60	110	525	OBM3060	OBB3060	0AS8040GC - 06136
82591	80	40	400	635	95	30	30	60	G 3/8"	60	110	575	OBM3060	OBB3060	0AS8040GC - 06136
82592	80	40	450	685	95	30	30	60	G 3/8"	60	110	625	OBM3060	OBB3060	0AS8040GC - 06136

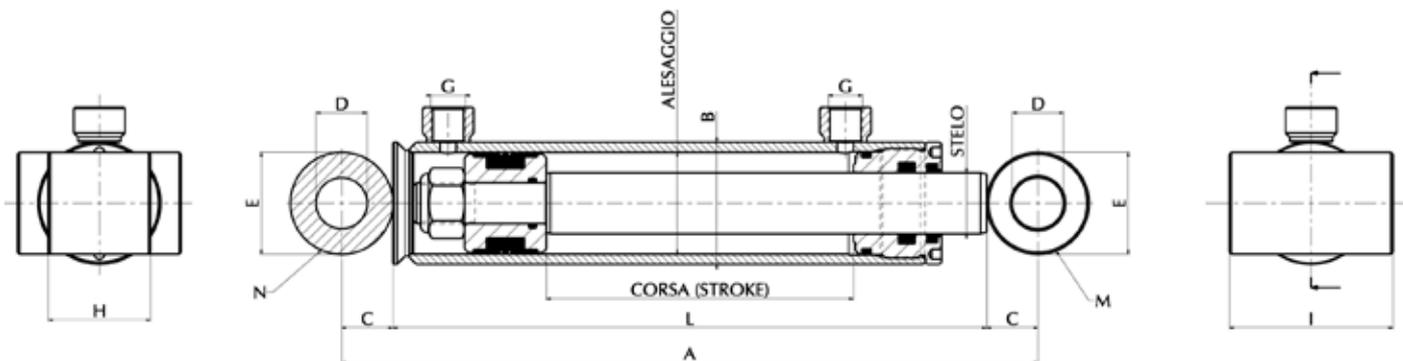

Art./ Ref.	Alesaggio/ Bore	Stelo Ø/ Rod Ø	Corsa/ Stroke	Misura A mm/A size mm	Misura B mm/B size mm	Misura C mm/C size mm	Misura D mm/D size mm	Misura E mm/E size mm	Misura G mm/G size mm	Misura H mm/H size mm	Misura I mm/I size mm	Misura L mm/L size mm	Misura M mm/M size mm	Misura N mm/N size mm	Kit testa-kit pistone/ Rod guide kit-piston kit
82593	80	40	500	735	95	30	30	60	G 3/8"	60	110	675	OBB3060	OBB3060	OAS8040GC - 06136
82594	80	40	550	785	95	30	30	60	G 3/8"	60	110	725	OBB3060	OBB3060	OAS8040GC - 06136
82595	80	40	600	835	95	30	30	60	G 3/8"	60	110	775	OBB3060	OBB3060	OAS8040GC - 06136
82596	80	40	650	885	95	30	30	60	G 3/8"	60	110	825	OBB3060	OBB3060	OAS8040GC - 06136
82597	80	40	700	935	95	30	30	60	G 3/8"	60	110	875	OBB3060	OBB3060	OAS8040GC - 06136
82598	80	40	750	985	95	30	30	60	G 3/8"	60	110	925	OBB3060	OBB3060	OAS8040GC - 06136
82599	80	40	800	1035	95	30	30	60	G 3/8"	60	110	975	OBB3060	OBB3060	OAS8040GC - 06136
82600	80	40	850	1085	95	30	30	60	G 3/8"	60	110	1025	OBB3060	OBB3060	OAS8040GC - 06136
82601	80	40	900	1135	95	30	30	60	G 3/8"	60	110	1075	OBB3060	OBB3060	OAS8040GC - 06136
82602	80	40	950	1185	95	30	30	60	G 3/8"	60	110	1125	OBB3060	OBB3060	OAS8040GC - 06136
82603	80	40	1000	1235	95	30	30	60	G 3/8"	60	110	1175	OBB3060	OBB3060	OAS8040GC - 06136
82604	80	50	100	335	95	30	30	60	G 3/8"	60	110	275	OBB3060	OBB3060	OAS8040GC - 06136
82605	80	50	150	385	95	30	30	60	G 3/8"	60	110	325	OBB3060	OBB3060	OAS8040GC - 06136
82606	80	50	200	435	95	30	30	60	G 3/8"	60	110	375	OBB3060	OBB3060	OAS8050GC - 06136
82607	80	50	250	485	95	30	30	60	G 3/8"	60	110	425	OBB3060	OBB3060	OAS8050GC - 06136
82608	80	50	300	535	95	30	30	60	G 3/8"	60	110	475	OBB3060	OBB3060	OAS8050GC - 06136
82609	80	50	350	585	95	30	30	60	G 3/8"	60	110	525	OBB3060	OBB3060	OAS8050GC - 06136
82610	80	50	400	635	95	30	30	60	G 3/8"	60	110	575	OBB3060	OBB3060	OAS8050GC - 06136
82611	80	50	450	685	95	30	30	60	G 3/8"	60	110	625	OBB3060	OBB3060	OAS8050GC - 06136
82612	80	50	500	735	95	30	30	60	G 3/8"	60	110	675	OBB3060	OBB3060	OAS8050GC - 06136
82613	80	50	550	785	95	30	30	60	G 3/8"	60	110	725	OBB3060	OBB3060	OAS8050GC - 06136
82614	80	50	600	835	95	30	30	60	G 3/8"	60	110	775	OBB3060	OBB3060	OAS8050GC - 06136
82615	80	50	650	885	95	30	30	60	G 3/8"	60	110	825	OBB3060	OBB3060	OAS8050GC - 06136
82616	80	50	700	935	95	30	30	60	G 3/8"	60	110	875	OBB3060	OBB3060	OAS8050GC - 06136
82617	80	50	750	985	95	30	30	60	G 3/8"	60	110	925	OBB3060	OBB3060	OAS8050GC - 06136
82618	80	50	800	1035	95	30	30	60	G 3/8"	60	110	975	OBB3060	OBB3060	OAS8050GC - 06136
82619	80	50	850	1085	95	30	30	60	G 3/8"	60	110	1025	OBB3060	OBB3060	OAS8050GC - 06136
82620	80	50	900	1135	95	30	30	60	G 3/8"	60	110	1075	OBB3060	OBB3060	OAS8050GC - 06136
82621	80	50	950	1185	95	30	30	60	G 3/8"	60	110	1125	OBB3060	OBB3060	OAS8050GC - 06136
82622	80	50	1000	1235	95	30	30	60	G 3/8"	60	110	1175	OBB3060	OBB3060	OAS8050GC - 06136

CILINDRI TUFFANTE

VERINS PLONGEUR

HYDRAULIC PLUNGER CYLINDERS

PLUNGERZYLINDER

CILINDROS CON CASQUILLOS

ЦИЛИНДРЫ ПЛУНЖЕРНЫЕ

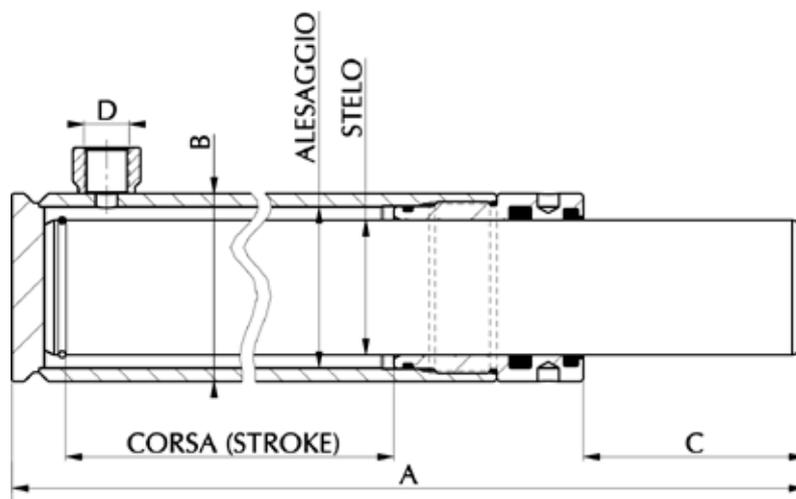

Art./Ref.	Alesaggio/ Bore	Stelo Ø/Rod Ø	Corsa/Stroke	Misura A mm/ A size mm	Misura B mm/ B size mm	Misura C mm/ C size mm	Misura D mm/ D size mm	Kit guarnizioni/Seals kit
0403020T	40	30	200	323	50	40	3/8"	18117
0403025T	40	30	250	373	50	40	3/8"	18117
0403030T	40	30	300	423	50	40	3/8"	18117
0403035T	40	30	350	473	50	40	3/8"	18117
0403040T	40	30	400	523	50	40	3/8"	18117
0403050T	40	30	500	623	50	40	3/8"	18117
0504020T	50	40	200	340	60	45	3/8"	18119
0504030T	50	40	300	440	60	45	3/8"	18119
0504040T	50	40	400	540	60	45	3/8"	18119
0504050T	50	40	500	640	60	45	3/8"	18119
0504060T	50	40	600	740	60	45	3/8"	18121
0605030T	60	50	300	467	70	50	3/8"	18121
0605040T	60	50	400	562	70	50	3/8"	18121
0605050T	60	50	500	662	70	50	3/8"	18121
0605060T	60	50	600	762	70	50	3/8"	18121

CILINDRI TUFFANTE CON FORI

VERINS PLONGEUR PERCE

HYDRAULIC PLUNGER CYLINDERS WITH BORES

PLUNGERZYLINDER MIT BOHRUNG

CILINDROS CON CASQUILLOS TALDRADO

ЦИЛИНДРЫ ПЛУНЖЕРНЫЕ С ОТВЕРСТИЕМ

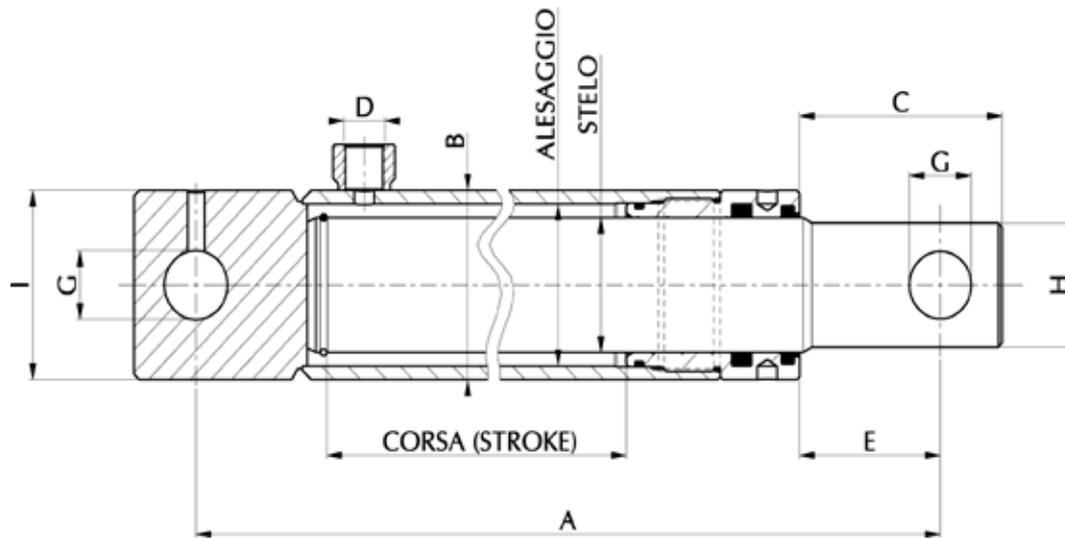

Art./Ref.	Alesaggio/ Bore	Stelo Ø/Rod Ø	Corsa/Stroke	Misura A mm/A size mm	Misura B mm/B size mm	Misura C mm/C size mm	Misura D mm/D size mm	Misura E mm/E size mm	Misura G mm/G size mm	Misura H mm/H size mm	Misura I mm/I size mm	Kit guarnizioni/Seals kit
80724	30	25	100	190	40	38	3/8"	24	14	22	40	
80725	30	25	150	240	40	38	3/8"	24	14	22	40	
80726	30	25	200	290	40	38	3/8"	24	14	22	40	
80727	30	25	250	340	40	38	3/8"	24	14	22	40	
80728	30	25	300	390	40	38	3/8"	24	14	22	40	
80729	40	30	200	300	50	42	3/8"	26	16	27	50	18117
80730	40	30	250	350	50	42	3/8"	26	16	27	50	18117
80731	40	30	300	400	50	42	3/8"	26	16	27	50	18117
80732	40	30	350	450	50	42	3/8"	26	16	27	50	18117
80733	40	30	400	500	50	42	3/8"	26	16	27	50	18117
80734	40	30	550	650	50	42	3/8"	26	16	27	50	18117
80735	50	40	200	330	60	54	3/8"	32	23	37	60	18119
80736	50	40	250	380	60	54	3/8"	32	23	37	60	18119
80737	50	40	300	430	60	54	3/8"	32	23	37	60	18119
80738	50	40	350	480	60	54	3/8"	32	23	37	60	18119
80739	50	40	400	530	60	54	3/8"	32	23	37	60	18119
80740	50	40	550	680	60	54	3/8"	32	23	37	60	18119
80741	50	40	700	830	60	54	3/8"	32	23	37	60	18119
80742	60	50	300	460	70	74	3/8"	49	25,5	47	65	18121
80743	60	50	400	560	70	74	3/8"	49	25,5	47	65	18121
78706	60	50	550	710	70	74	3/8"	49	25,5	47	65	18121
78707	60	50	700	860	70	74	3/8"	49	25,5	47	65	18121

CILINDRO SFILANTE DOPPIO EFFETTO

VÉRINS A DOUBLE EFFET A 2 EXPANSIONS

HYDRAULIC CYLINDER DOUBLE ACTING WITH 2 EXTENSIONS

ZYLINDER DOPPELWIRKEND MIT 2 STUFEN

CILINDRO DOBLE EFECTO CON 2 EXTENSIONES

РАЗДВИЖНОЙ ЦИЛИНДР ДВОЙНОГО ДЕЙСТВИЯ

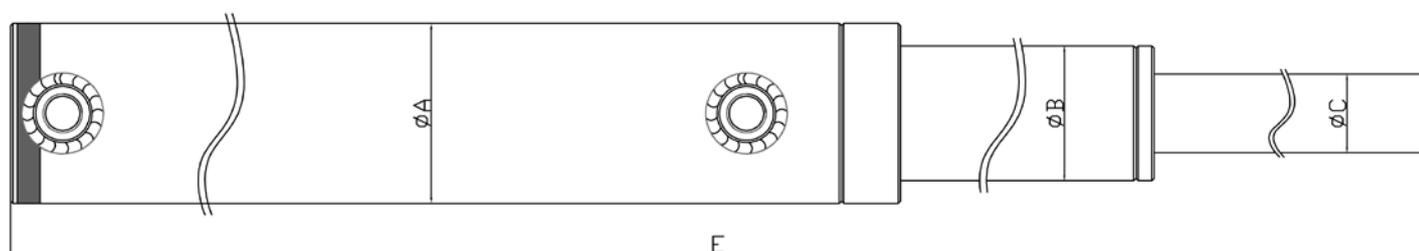
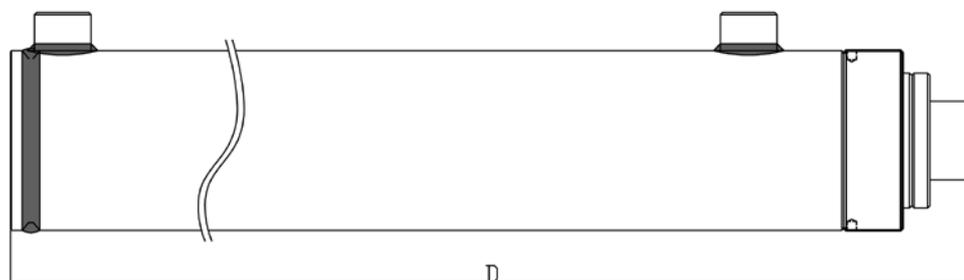

Art./Ref.	Sfilata/ Extension	Alesaggio/Bore	Corsa/Stroke	Misura A mm/A size mm	Misura B mm/B size mm	Misura C mm/C size mm	Misura D mm/D size mm	Misura E mm/E size mm
82662	2	70	150	80	60	35	270	420
82670	2	70	270	80	60	35	330	600
82675	2	70	470	80	60	35	430	900
82751	2	70	670	80	60	35	530	1200
82754	2	70	870	80	60	35	630	1500

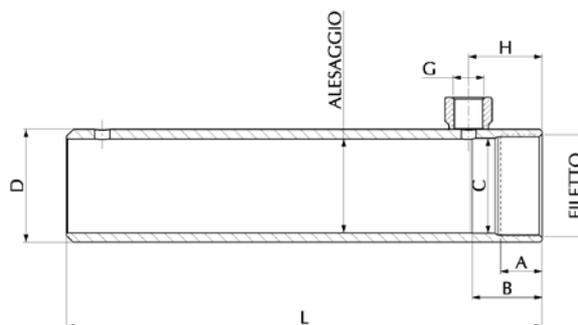
TUBO TORNITO CON BORCHIA SALDATA
TUBE TOURNE' AVEC DOUILLE SOUDE'
THREADED CYLINDER TUBE WITH WELDED CONNECTION
GEDREHTES ZYLINDERROHR MIT ANGESCHWEISSTEM ANSCHLUSSGEWINDE
TUBO TORNADO CON ENTRADA SOLDADA
ТРУБКА ОБТОЧЕННАЯ СО СВАРОЧНОЙ БОЙКОЙ

Art./Ref.	Alesaggio/ Bore	Corsa/Stroke	Filetto/ Thread	Misura A mm/ A size mm	Misura B mm/ B size mm	Misura C mm/ C size mm	Misura D mm/ D size mm	Misura G mm/ G size mm	Misura H mm/ H size mm	Misura L mm/ L size mm	Peso kg/ Weight kg
OTA4015	40	150	44X1,5	21	34	40,6	50	1/4"	34	242	1,34
OTA4020	40	200	44X1,5	21	34	40,6	50	1/4"	34	292	1,62
OTA4025	40	250	44X1,5	21	34	40,6	50	1/4"	34	342	1,89
OTA4030	40	300	44X1,5	21	34	40,6	50	1/4"	34	392	2,17
OTA4040	40	400	44X1,5	21	34	40,6	50	1/4"	34	492	2,73
OTA5015	50	150	54X1,5	24	37	50,6	60	3/8"	37	252	1,70
OTA5020	50	200	54X1,5	24	37	50,6	60	3/8"	37	302	2,04
OTA5025	50	250	54X1,5	24	37	50,6	60	3/8"	37	352	2,38
OTA5030	50	300	54X1,5	24	37	50,6	60	3/8"	37	402	2,72
OTA5040	50	400	54X1,5	24	37	50,6	60	3/8"	37	502	3,40
OTA5050	50	500	54X1,5	24	37	50,6	60	3/8"	37	602	4,08
OTA5060	50	600	54X1,5	24	37	50,6	60	3/8"	37	702	4,75
OTA6015	60	150	64X1,5	29	42	60,6	70	3/8"	45	267	2,13
OTA6020	60	200	64X1,5	29	42	60,6	70	3/8"	45	317	2,53
OTA6025	60	250	64X1,5	29	42	60,6	70	3/8"	45	367	2,93
OTA6030	60	300	64X1,5	29	42	60,6	70	3/8"	45	417	3,34
OTA6040	60	400	64X1,5	29	42	60,6	70	3/8"	45	517	4,13
OTA6050	60	500	64X1,5	29	42	60,6	70	3/8"	45	617	4,93
OTA6060	60	600	64X1,5	29	42	60,6	70	3/8"	45	717	5,73
OTA6320	63	200	68X1,5	29	42	63,6	73	3/8"	45	317	2,66
OTA6325	63	250	68X1,5	29	42	63,6	73	3/8"	45	367	3,08
OTA6330	63	300	68X1,5	29	42	63,6	73	3/8"	45	417	3,50
OTA6340	63	400	68X1,5	29	42	63,6	73	3/8"	45	517	4,34
OTA6350	63	500	68X1,5	29	42	63,6	73	3/8"	45	617	5,18
OTA6360	63	600	68X1,5	29	42	63,6	73	3/8"	45	717	6,02
OTA7020	70	200	74X1,5	29	42	70,6	80	3/8"	45	317	2,93
OTA7025	70	250	74X1,5	29	42	70,6	80	3/8"	45	367	3,35
OTA7030	70	300	74X1,5	29	42	70,6	80	3/8"	45	417	3,85
OTA7040	70	400	74X1,5	29	42	70,6	80	3/8"	45	517	4,78
OTA7050	70	500	74X1,5	29	42	70,6	80	3/8"	45	617	5,70
OTA7060	70	600	74X1,5	29	42	70,6	80	3/8"	45	717	6,63
OTA8020	80	200	85X20	35	52	80,6	95	3/8"	55	330	5,35
OTA8025	80	250	85X20	35	52	80,6	95	3/8"	55	380	6,15
OTA8030	80	300	85X20	35	52	80,6	95	3/8"	55	430	6,97
OTA8040	80	400	85X20	35	52	80,6	95	3/8"	55	530	8,60
OTA8050	80	500	85X20	35	52	80,6	95	3/8"	55	630	10,2
OTA8060	80	600	85X20	35	52	80,6	95	3/8"	55	730	11,8
OTAA125	100	250	105X20	35	52	100,6	115	3/8"	55	392	7,80
OTAA130	100	300	105X20	35	52	100,6	115	3/8"	55	442	8,80
OTAA140	100	400	105X20	35	52	100,6	115	3/8"	55	542	10,8
OTAA150	100	500	105X20	35	52	100,6	115	3/8"	55	642	12,8
OTAA160	100	600	105X20	35	52	100,6	115	3/8"	55	742	14,8

BARRA CROMATA TORNITA

BARRE CHROMEÉ TURNEE

CHROME PLATED TURNED RODS

GEDREHTE CHROMSTANGE

BARRA COMADA TORNEADA

ПРУТ ХРОМИРОВАННЫЙ ОБТОЧЕННЫЙ



Art./Ref.	Alesaggio/ Bore	Stelo Ø/Rod Ø	Corsa/Stroke	Filetto/ Thread	Misura A mm/ A size mm	Misura B mm/ B size mm	Misura C mm/ C size mm	Misura L mm/ L size mm	Peso kg/ Weight kg
OBC2015	35/40	20	150	14x1,5	35	23	15	270	0,59
OBC2020	35/40	20	200	14x1,5	35	23	15	320	0,71
OBC2025	35/40	20	250	14x1,5	35	23	15	370	0,84
OBC2030	35/40	20	300	14x1,5	35	23	15	420	0,96
OBC2040	35/40	20	400	14x1,5	35	23	15	520	1,21
OBC2515	40	25	150	14x1,5	35	23	15	270	0,88
OBC2520	40	25	200	14x1,5	35	23	15	320	1,07
OBC2525	40	25	250	14x1,5	35	23	15	370	1,27
OBC2530	40	25	300	14x1,5	35	23	15	420	1,46
OBC2540	40	25	400	14x1,5	35	23	15	520	1,84
OBC2550	40	25	500	14x1,5	35	23	15	620	2,23
OBC2560	40	25	600	14x1,5	35	23	15	720	2,61
OBC2515L	50	25	150	20x1,5	35	30	20	280	0,98
OBC2520L	50	25	200	20x1,5	35	30	20	330	1,18
OBC2525L	50	25	250	20x1,5	35	30	20	380	1,37
OBC2530L	50	25	300	20x1,5	35	30	20	430	1,56
OBC2540L	50	25	400	20x1,5	35	30	20	530	1,95
OBC2550L	50	25	500	20x1,5	35	30	20	630	2,33
OBC2560L	50	25	600	20x1,5	35	30	20	730	2,72
OBC3015	50	30	150	20x1,5	35	30	20	280	1,35
OBC3020	50	30	200	20x1,5	35	30	20	330	1,63
OBC3025	50	30	250	20x1,5	35	30	20	380	1,90
OBC3030	50	30	300	20x1,5	35	30	20	430	2,18
OBC3040	50	30	400	20x1,5	35	30	20	530	2,74
OBC3050	50	30	500	20x1,5	35	30	20	630	3,29
OBC3060	50	30	600	20x1,5	35	30	20	730	3,85
OBC3015L	60/65	30	150	20x1,5	45	30	20	298	1,41
OBC3020L	60/65	30	200	20x1,5	45	30	20	348	1,69
OBC3025L	60/65	30	250	20x1,5	45	30	20	398	1,97
OBC3030L	60/65	30	300	20x1,5	45	30	20	448	2,25
OBC3040L	60	30	400	20x1,5	45	30	20	548	2,80
OBC3050L	60	30	500	20x1,5	45	30	20	648	3,36
OBC3060L	60	30	600	20x1,5	45	30	20	748	3,91
OBC3520	60	35	200	20x1,5	45	30	20	348	2,24
OBC3525	60	35	250	20x1,5	45	30	20	398	2,61
OBC3530	60	35	300	20x1,5	45	30	20	448	2,99
OBC3540	60	35	400	20x1,5	45	30	20	548	3,75
OBC3550	60	35	500	20x1,5	45	30	20	648	4,50
OBC3560	60	35	600	20x1,5	45	30	20	748	5,26
OBC3520L	70	35	200	27x2	45	30	27	348	2,39
OBC3525L	70	35	250	27x2	45	30	27	398	2,76
OBC3530L	70	35	300	27x2	45	30	27	448	3,14

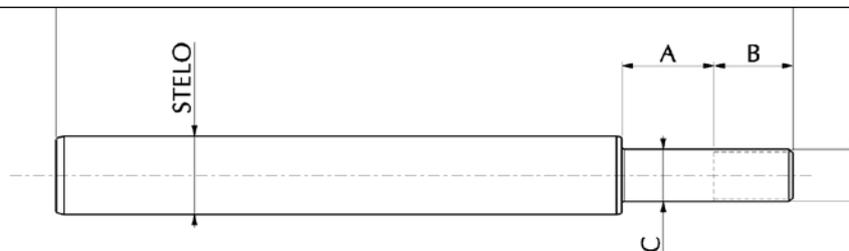

Art./Ref.	Alesaggio/ Bore	Stelo Ø/Rod Ø	Corsa/Stroke	Filetto/ Thread	Misura A mm/ A size mm	Misura B mm/ B size mm	Misura C mm/ C size mm	Misura L mm/ L size mm	Peso kg/ Weight kg
OBC3540L	70	35	400	27x2	45	30	27	548	3,90
OBC3550L	70	35	500	27x2	45	30	27	648	4,65
OBC3560L	70	35	600	27x2	45	30	27	748	5,41
OBC4020	60	40	200	27x2	45	30	27	348	3,02
OBC4025	60	40	250	27x2	45	30	27	398	3,51
OBC4030	60	40	300	27x2	45	30	27	448	3,71
OBC4040	60	40	400	27x2	45	30	27	548	4,99
OBC4050	60	40	500	27x2	45	30	27	648	5,97
OBC4060	60	40	600	27x2	45	30	27	748	6,96
OBC4020L	80	40	200	30x2	45	33	30	363	3,24
OBC4025L	80	40	250	30x2	45	33	30	413	3,63
OBC4030L	80	40	300	30x2	45	33	30	463	4,22
OBC4040L	80	40	400	30x2	45	33	30	563	5,21
OBC4050L	80	40	500	30x2	45	33	30	663	6,19
OBC4060L	80	40	600	30x2	45	33	30	763	7,18
OBC5020	80	50	200	30x2	45	33	30	363	4,81
OBC5025	80	50	250	30x2	45	33	30	413	5,43
OBC5030	80	50	300	30x2	45	33	30	463	6,35
OBC5040	80	50	400	30x2	45	33	30	563	7,89
OBC5050	80	50	500	30x2	45	33	30	663	9,43
OBC5060	80	50	600	30x2	45	33	30	763	10,9
OBC5020L	90	50	200	33x2	45	43	33	375	4,98
OBC5025L	90	50	250	33x2	45	43	33	425	5,75
OBC5030L	90	50	300	33x2	45	43	33	475	6,52
OBC5040L	90	50	400	33x2	45	43	33	575	8,06
OBC5050L	90	50	500	33x2	45	43	33	675	9,60
OBC5060L	90	50	600	33x2	45	43	33	775	11,1
OBC6025	100	60	200	33x2	45	43	33	425	8,05
OBC6030	100	60	300	33x2	45	43	33	475	9,16
OBC6040	100	60	400	33x2	45	43	33	575	11,3
OBC6050	100	60	500	33x2	45	43	33	675	13,6
OBC6060	100	60	600	33x2	45	43	33	775	15,8

TESTA DI GUIDA IN GHISA

TETE

ROD GUIDE

FÜHRUNG

CABEZA DE GUIA

НАПРАВЛЯЮЩАЯ ГОЛОВКА ЧУГУННАЯ

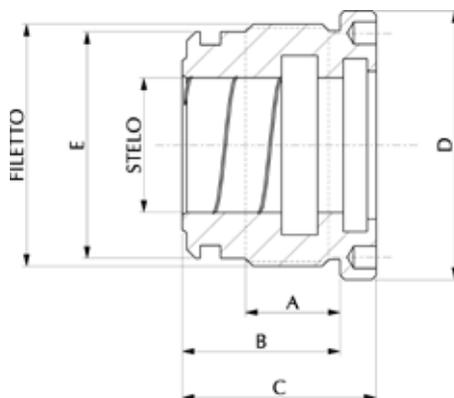
**Materiale:****Ghisa oleodinamica GG25 UNI 5007****Materials:****Hydraulic cast iron grade 260 BS**

Art./Ref.	Alesaggio/ Bore	Stelo Ø/Rod Ø	Filetto/ Thread	Misura A mm/ A size mm	Misura B mm/ B size mm	Misura C mm/ C size mm	Misura D mm/ D size mm	Misura E mm/ E size mm	Peso kg/ Weight kg	Kit guarnizioni a ricambio/Spare seals kit
0GC3016	30	16	34X1,5	18	34	42	40	30,5	0,12	0AS3016GC
0GC3020	30	20	34X1,5	18	32	40	40	30,5	0,14	0AS3020GC
0GC3220	32	20	36X1,5	14	27	33	40	32,5	0,18	0AS3220GC
0GC3515	35	15	39X1,5	16	28	34	45	35,5	0,22	0AS3515GC
0GC3520	35	20	39X1,5	18	32	40	45	35,5	0,20	0AS3520GC
0GC4016	40	16	44X1,5	18	32	40	50	40,5	0,28	0AS4016GC
0GC4020	40	20	44X1,5	18	32	40	50	40,5	0,32	0AS4020GC
0GC4022	40	22	44X1,5	18	32	40	50	40,5	0,28	0AS4022GC
0GC4025	40	25	44X1,5	17	32	40	50	40,5	0,26	0AS4025GC
0GC4028	40	28	44X1,5	18	32	55	50	40,5	0,24	0AS4028GC
0GC4522	45	22	49X1,5	18,5	32	40	55	45,5	0,37	0AS4522GC
0GC4525	45	25	49X1,5	18	32	40	55	45,5	0,33	0AS4525GC
0GC5025	50	25	54X1,5	22	35	43	60	50,5	0,53	0AS5025GC
0GC5030	50	30	54X1,5	21	35	43	60	50,5	0,45	0AS5030GC
80764	50	35	54X1,5	17	30	38	60	50,5	0,29	0AS5035GC
0GC5035	50	35	54X1,5	22	35	43	60	50,5	0,40	0AS5035GC
0GC5525	55	25	59X1,5	20	35	43	65	55,5	0,48	0AS5525GC
80765	55	25	60X1,5	21	35	43	65	55,5	0,68	0AS5525GC
0GC5530	55	30	59X1,5	20	35	43	65	55,5	0,51	0AS5530GC
80766	55	30	60X1,5	21	35	43	65	55,5	0,54	0AS5530GC
0GC5535	55	35	59X1,5	20	35	43	65	55,5	0,43	0AS5535GC
80767	55	35	60X1,5	21	35	43	65	55,5	0,45	0AS5535GC
0GC6030	60	30	64X1,5	26	40	50	70	60,5	0,92	0AS6030GC
0GC6035	60	35	64X1,5	25	40	50	70	60,5	0,81	0AS6035GC
0GC6040	60	40	64X1,5	26	40	50	70	60,5	0,70	0AS6040GC
0GC6330	63	30	68X1,5	26	40	50	73	63,5	0,88	0AS6330GC
0GC6335	63	35	68X1,5	26	40	50	73	63,5	0,82	0AS6335GC
0GC6340	63	40	68X1,5	26	40	50	73	63,5	0,75	0AS6340GC
80768	65	30	69X1,5	25	40	50	75	65,5	1,25	0AS6530GC
0GC6530	65	30	69X1,5	30	50	60	75	65,5	1,70	0AS6530GC
80769	65	35	69X1,5	25	40	50	75	65,5	1,11	0AS6535GC
0GC6535	65	35	69X1,5	30	50	60	75	65,5	1,06	0AS6535GC
80770	65	40	69X1,5	25	40	50	75	65,5	0,98	0AS6540GC
0GC6540	65	40	69X1,5	30	50	60	75	65,5	0,95	0AS6540GC

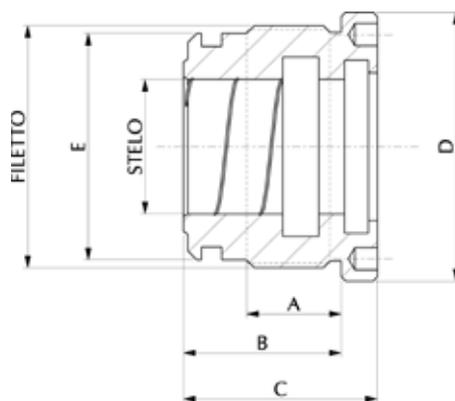

Art./Ref.	Alesaggio/ Bore	Stelo \varnothing /Rod \varnothing	Filetto/ Thread	Misura A mm/ A size mm	Misura B mm/ B size mm	Misura C mm/ C size mm	Misura D mm/ D size mm	Misura E mm/ E size mm	Peso kg/ Weight kg	Kit guarnizioni a ricambio/Spare seals kit
OGC7030	70	30	74X1,5	26	40	50	80	70,5	1,70	OAS7030GC
OGC7035	70	35	74X1,5	25	40	50	80	70,5	1,80	OAS7035GC
OGC7040	70	40	74X1,5	25	40	50	80	70,5	1,10	OAS7040GC
OGC7530	75	30	80X1,5	30	50	60	85	75,5	1,69	OAS7530GC
80771	75	30	80X2	33	50	60	85	75,5	1,72	OAS7530GC
OGC7535	75	35	80X1,5	30	50	60	85	75,5	1,58	OAS7035GC
80772	75	35	80X2	33	50	60	85	75,5	1,62	OAS7535GC
OGC7540	75	40	80X1,5	30	50	60	85	75,5	1,46	OAS7540GC
80773	75	40	80X2	33	50	60	85	75,5	1,46	OAS7540GC
OGC7545	75	45	80X1,5	30	50	60	85	75,5	1,33	OAS7545GC
80774	75	45	80X2	33	50	60	85	75,5	1,33	OAS7545GC
OGC8040	80	40	85X2	29	50	60	92	80,5	1,75	OAS8040GC
OGC8045	80	45	85X2	30	50	60	92	80,5	1,60	OAS8045GC
OGC8050	80	50	85X2	30	50	60	92	80,5	1,40	OAS8050GC
OGC8060	80	60	85X2	30	50	60	90	80,5	1,30	OAS8060GC
OGC8535	85	35	90X2	30	50	60	100	85,5	2,08	OAS8535GC
OGC8540	85	40	90X2	30	50	60	100	85,5	1,90	OAS8540GC
OGC8545	85	45	90X2	30	50	60	100	85,5	1,85	OAS8545GC
OGC8550	85	50	90X2	30	50	60	100	85,5	1,76	OAS8550GC
OGC9040	90	40	95X2	32	50	60	100	90,5	2,10	OAS9040GC
OGC9045	90	45	95X2	32	50	60	100	90,5	1,99	OAS9045GC
OGC9050	90	50	95X2	32	50	60	100	90,5	1,91	OAS9050GC
OGCA140	100	40	105X2	32	50	62	115	100,5	3,07	OAS140GCA
80775	100	40	105X2	51	70	82	115	100,5	4,14	OAS140GCA
OGCA145	100	45	105X2	32	50	62	115	100,5	2,93	OAS145GCA
80776	100	45	105X2	51	70	82	115	100,5	3,94	OAS145GCA
OGCA150	100	50	105X2	32	50	62	115	100,5	2,79	OAS150GCA
80777	100	50	105X2	51	70	82	115	100,5	3,71	OAS150GCA
OGCA155	100	55	105X2	32	50	62	115	100,5	2,64	OAS155GCA
80778	100	55	105,2	51	70	82	115	100,5	3,68	OAS155GCA
OGCA160	100	60	105X2	32	50	62	115	100,5	2,50	OAS160GCA
OGC1160	110	60	115X2	42	70	82	125	110,5	6	OAS11060GC
80779	100	60	105X2	51	70	82	115	100,5	3,13	OAS160GCA
OGC1170	110	70	115X2	42	70	82	130	110,5	5,40	OAS11070GC
OGC1260	120	60	125X2	42	70	82	140	120,5	7	OAS12060GC
OGC1270	120	70	125X2	42	70	82	140	120,5	6,40	OAS12070GC
OGC1280	120	80	125X2	42	70	82	140	120,5	6	OAS12080GC
OGC1370	130	70	135X2	60	90	102	140	130,5	7,50	OAS13070GC
OGC1380	130	80	135X2	60	90	102	140	135,2	8	OAS13080GC
OGC1470	140	70	145X2	60	90	102	150	140,5	12	OAS14070GC
OGC1480	140	80	145X2	60	90	102	150	140,5	11	OAS14080GC
OGC1570	150	70	155X2	60	90	102	160	150,5	13	OAS15070GC
OGC1580	150	80	155x2	60	90	102	160	150,5	12	OAS15080GC

TESTATE DI GUIDA TUFFANTI

TETE DE GUIDAGE PLONGEUR

DISPLACEMENT RAM HEAD BUSH

PLUNGER KOLBENSTANGENFUEHRUNG

CABEZAS DE GUIA PARA CILINDROS TIPO BUZO

ГОЛОВКИ НАПРАВЛЕНИЯ ПРОТЕСТИРОВАННЫЕ

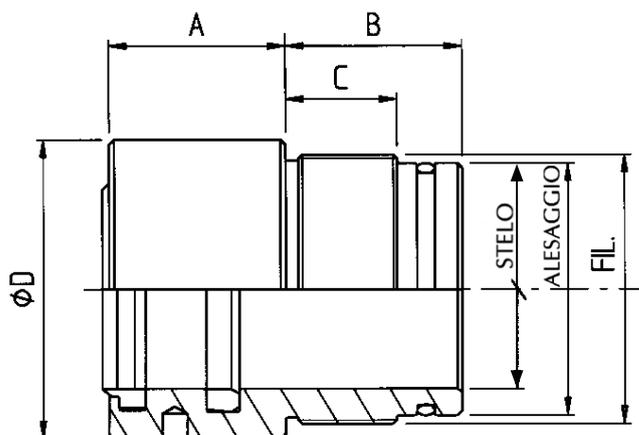
**Materiale:**

Ghisa oleodinamica GG25 UNI 5007

Materials:

Hydraulic cast iron grade 260 BS

Art./Ref.	Alesaggio/ Bore	Stelo \emptyset /Rod \emptyset	Filetto/ Thread	Misura A mm/ A size mm	Misura B mm/ B size mm	Misura C mm/ C size mm	Misura D mm/ D size mm	Peso kg/ Weight kg
OGT2535	35	25	39X1,5	33	32	18	45	0,33
OGT3040	40	30	44X1,5	33	32	18	50	0,39
OGT4050	50	40	54X1,5	35	35	22	60	0,53
OGT4555	55	45	60X1,5	35	35	22	65	0,61
OGT5060	60	50	64X1,5	35	40	26	70	0,65
OGT6070	70	60	74X1,5	35	40	26	80	0,77

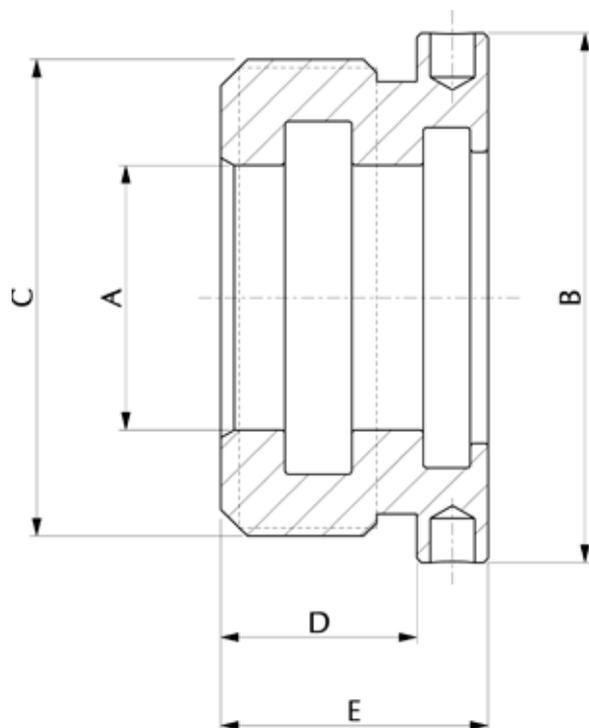
TESTA DI GUIDA IN GHISA CORTA
TETE COURTE
SHORT ROD GUIDE
KURZE FÜHRUNGSKOPFE
CABEZA DE GUIA CORTA
НАПРАВЛЯЮЩАЯ ГОЛОВКА ЧУГУННАЯ КОРОТКАЯ

Art./Ref.	Alesaggio/ Bore	Misura A mm/ A size mm	Misura B mm/ B size mm	Misura C mm/ C size mm	Misura D mm/ D size mm	Misura E mm/ E size mm	Peso kg/ Weight kg	Kit guarnizioni a ricambio/Spare seals kit
80763	25	16	35	28X1,5	12	30	0,10	
2GC3016R	30	16	40	34X1,5	18	26	0,17	0AS30162GCR
2GC3520R	35	20	45	39X1,5	18	26	0,18	
2GC4020R	40	20	50	44X1,5	18	26	0,25	0AS40202GCR
2GC4025R	40	25	50	44X1,5	18	26	0,20	0AS40252GCR
2GC5025R	50	25	60	54X1,5	22	30	0,45	0AS50252GCR
2GC5030R	50	30	60	54X1,5	22	30	0,39	0AS50302GCR
2GC6030R	60	30	70	64X1,5	26	36	0,78	0AS60302GCR
2GC6035R	60	35	70	64X1,5	26	36	0,74	0AS60352GCR
2GC6330R	63	30	73	67X1,5	26	36	0,80	
2GC6335R	63	35	73	68X1,5	26	36	0,78	
2GC7035R	70	35	80	74X1,5	26	36	1,70	0AS70352GCR
2GC7040R	70	40	80	74X1,5	26	36	1,20	0AS70402GCR
2GC8040R	80	40	95	85X2	32	42	1,75	0AS80402GCR
2GC8045R	80	45	95	85X2	32	42	1,70	0AS80452GCR
2GC8050R	80	50	95	85X2	32	42	1,40	0AS80502GCR
2GC9040R	90	40	105	95X2	32	42	1,85	
2GC9050R	90	50	105	95X2	32	42	1,75	

PISTONE

PISTON

PISTON

ZYLINDERKOPF

PISTÓN

ПОРШЕНЬ

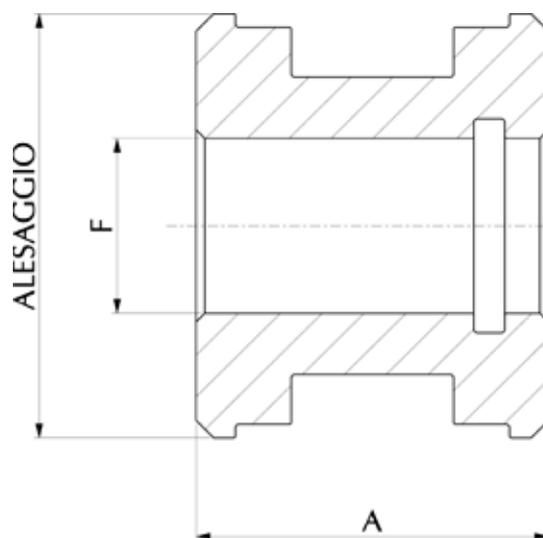

Materiale: acciaio cf9s Mn Pb 36 UNI 5105

Materials: STEEL 230 M07 Pb BS

Art./Ref.	Alesaggio/Bore	Misura A mm/A size mm	Misura F mm/F size mm	Peso kg/Weight kg	Kit guarnizioni a ricambio/Spare seals kit
YTC2510AD	25	25	10	0,10	0AS2510TC
OTC3014	30	28	14	0,12	0AS3014TC
OTC3215	32	40	15	0,15	80723
OTC3514	35	40	15	0,18	18216
OTC4014	40	40	15	0,22	06130
OTC4515	45	40	15	0,27	0AS4515TC
OTC5020	50	40	20	0,31	06132
OTC5520	55	40	20	0,46	0AS5520TC
OTC6020	60	50	20	0,61	06133
OTC6027	60	50	27	0,51	18219
OTC6320	63	50	20	0,70	0AS6320TC
OTC6327	63	50	27	0,65	18218
OTC6330	63	50	30	0,68	0AS6330TC
OTC6520	65	50	20	0,70	0AS6520TC
OTC6524	65	50	24	0,68	0AS6524TC
OTC7027	70	50	27	0,79	06135
OTC7524	75	50	24	0,98	0AS7524TC
OTC8027	80	50	27	1,23	0AS8027TC
OTC8030	80	50	30	1,20	06136
OTC8033	80	50	33	1,17	0AS8033TC
OTC8527	85	50	27	1,43	0AS8527TC
OTC8530	85	50	30	1,40	0AS8530TC
OTC9030	90	50	30	1,63	06137
OTC9033	90	50	33	1,56	18217
OTCA133	100	50	33	1,95	06138
OTC1140	110	50	40	2,60	0AS11040TC
OTC1240	120	50	40	2,98	0AS12040TC
OTC1340	130	58	40	4,00	0AS13040TC
OTC1440	140	58	40	5,09	0AS14040TC
OTC1540	150	58	40	6,02	0AS15040TC

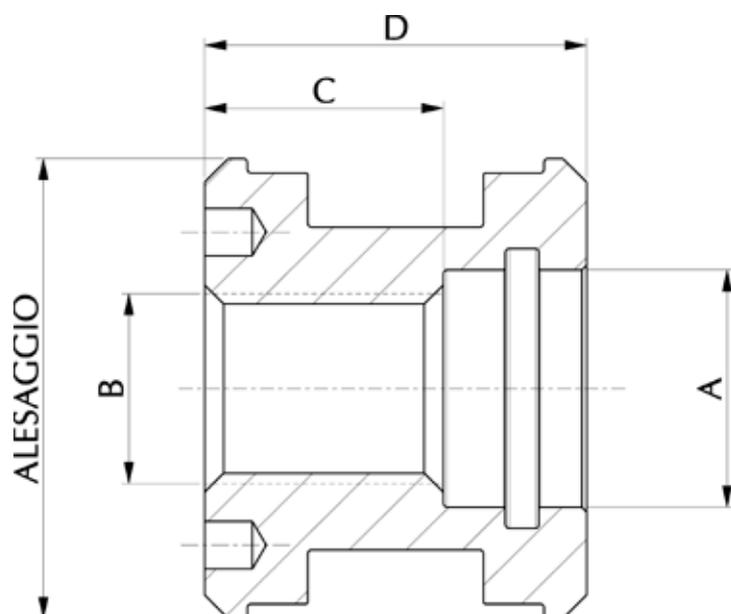
PISTONI FILETTATI
PISTON FILETE
THREADED PISTONS
ZYLINDERKOPF MIT GEWINDE
PISTÓN ROSCADO
ПОРШНИ С РЕЗЬБОЙ

Art./Ref.	Alesaggio/ Bore	Misura A mm/ A size mm	Misura B mm/ B size mm	Misura C mm/ C size mm	Misura D mm/ D size mm	Peso kg/ Weight kg	Kit guarnizioni a ricambio/Spare seals kit
2TC3012R	30	14	12X1,5	21	28	0,10	0AS3014TC
2TC3214T	32	20	14X1,5	30	40	0,12	0AS32142TCT
2TC3512T	35	15	12x1	19	29	0,15	0AS35122TCT
2TC3514T	35	18	14X1,5	30	40	0,17	0AS35142TCT
2TC4014T	40	20	14X1,5	25	40	0,20	0AS40142TCT
2TC4518T	45	22	18X1,5	25	40	0,18	0AS45182TCT
2TC5018T	50	25	18X1,5	25	40	0,31	0AS50182TCT
2TC5020T	50	25	20X2	25	40	0,31	0AS50182TCT
2TC5520T	55	25	20X1,5	27	42	0,45	0AS55202TCT
2TC5524T	55	30	24X2	27	42	0,40	0AS55242TCT
2TC6024T	60	30	24X2	27	42	0,58	0AS60242TCT
2TC6324T	63	30	24X2	27	42	0,66	0AS63242TCT
2TC6524T	65	30	24X2	35	50	0,70	0AS65242TCT
2TC7027T	70	35	27X2	35	50	0,78	0AS70272TCT
2TC7030T	70	35	30X2	35	50	0,78	0AS70272TCT
2TC7033T	70	40	33X2	35	50	0,75	0AS70332TCT
2TC7530T	75	35	30X3	35	50	0,90	0AS75302TCT
2TC8033T	80	40	33X2	35	50	1,08	0AS80332TCT
2TC8527T	85	30	27X2	35	50	1,30	0AS85272TCT
2TC9033T	90	40	33X2	35	50	1,57	0AS90332TCT
2TC9039T	90	40	39X4	35	50	1,57	0AS90332TCT
2TCA133T	100	40	33X2	35	50	2,18	0AS100332TCT
2TC10042T	100	50	42X4,5	57	74	2,10	0AS100422TCT
2TC1139T	110	45	39X2	35	50	2,40	0AS110392TCT

KIT GUARNIZIONI TESTA PER CILINDRI STANDARD

KIT DE JOINTS TÊTE POUR VERINS STANDARD
ROD GUIDE SEALING KIT FOR STANDARD CYLINDERS
DICHTUNGSATZ FÜR STANDARD ZYLINDERKOPF
KIT JUNTAS CABEZA PARA CILINDROS HIDRAULICOS
НАБОР УПЛОТНЕНИЙ ДЛЯ ГОЛОВКИ ЦИЛИНДРА СТАНДАРТНОГО

Kit composto da /set made up of:

- N.1 O-Ring
- N.1 Raschiatore/ rod wiper
- N.1 Tenuta stelo/ semicompact rod seal

Materiali/material:

- O-Ring: gomma nitrilica NBR 70° ShA/ nitrile rubber NBR 70° ShA
- Raschiatore/ rod wiper: poliuretano 93° ShA/ polyurethane 93° ShA
- Tenuta stelo / semicompact seal: poliuretano 93° ShA/ polyurethane 93° ShA

Art./Ref.	Alesaggio/Bore	Stelo/Rod
0AS2516GC	25	16
0AS3220GC	32	20
0AS3520GC	35	20
0AS4020GC	40	20
0AS4025GC	40	25
0AS5025GC	50	25
0AS5030GC	50	30
0AS6030GC	60	30
0AS6035GC	60	35
0AS6040GC	60	40
0AS6340GC	63	40
0AS7035GC	70	35
0AS7040GC	70	40
0AS8040GC	80	40
0AS8050GC	80	50
0AS9040GC	90	40
0AS9045GC	90	45
0AS9050GC	90	50
0AS150GCA	100	50
0AS160GCA	100	60

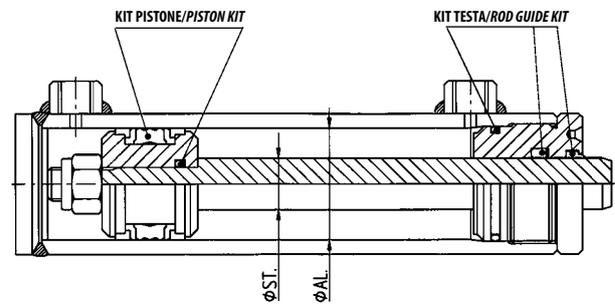

KIT GUARNIZIONI PISTONE PER CILINDRI STANDARD

KIT DE JOINTS PISTON POUR VERINS STANDARD
PISTON SEALING KIT FOR STANDARD CYLINDERS
DICHTUNGSATZ FÜR STANDARD ZYLINDERKOLBEN
KIT JUNTAS PISTON PARA CILINDROS HIDRAULICOS
НАБОР УПЛОТНЕНИЙ ДЛЯ ПОРШНЯ ЦИЛИНДРА СТАНДАРТНОГО

Kit composto da /set made up of:

- N.1 O-Ring
- N.1 Tenuta pistone/ double acting seal

Materiali/material:

- O-Ring: gomma nitrilica NBR 70° ShA/ nitrile rubber NBR 70° ShA
- Tenuta pistone/ double acting seal: gomma nitrilica NBR 75° ShA/ nitrile rubber NBR 75° ShA

Art./Ref.	Alesaggio/Bore	Stelo/Rod
83876	25	16
80723	32	20
18216	35	25
06130	40	20
06130	40	25
06132	50	25
06132	50	30
06133	60	30
06133	60	35
18219	60	40
18218	63	40
06135	70	35
06135	70	40
06136	80	40
06136	80	50
06137	90	40
06137	90	45
06137	90	50
06138	100	50
06138	100	60

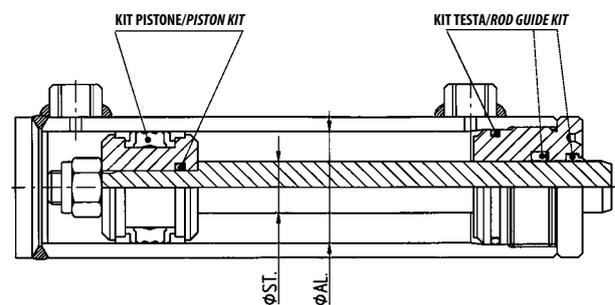

FONDELLO A SALDARE

FOND
 BOTTOM
 ZYLINDERBODEN
 TAPÓN DE SALDARE
 ФЛЮС СВАРОЧНЫЙ

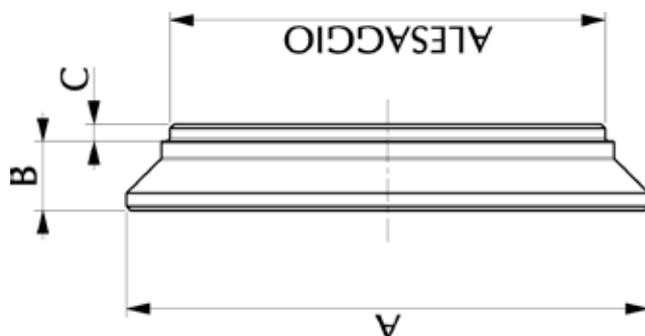

Materiale: acciaio cf9s Mn Pb 36 UNI 5105
Materials: STEEL 230 M07 Pb BS

Art./Ref.	Alesaggio/Bore	Misura A mm/ A size mm	Misura B mm/ B size mm	Misura C mm/ C size mm	Peso kg/Weight kg
YFS25AE	25	35	8	2	0,08
0FS30	30	40	8	2	0,10
YFS32AB	32	40	8	2	0,10
0FS35	35	45	8	2	0,12
0FS40	40	50	8	2	0,14
0FS45	45	55	8	2	0,16
0FS50	50	60	8	2	0,19
0FS55	55	65	10	2	0,27
0FS60	60	70	10	2	0,40
0FS63	63	73	10	2	0,42
0FS65	65	75	10	2	0,44
0FS70	70	80	10	2	0,47
0FS75	75	85	10	2	0,50
YFS80BU	80	90	10	2	0,60
0FS80	80	95	10	2	0,60
0FS85	85	100	13	2	0,70
0FS90	90	105	13	2	0,80
0FS100	100	115	13	2	1,00
0FS110	110	125	13	2	1,32
79137	110	130	13	2	1,25
0FS120	120	140	18	2	1,65
0FS125	125	145	16	4	1,88

FONDELLO CON FORO SPINA ELASTICA

FOND PERCE POUR GOUPILLE ELASTIQUE

BOTTOM WITH BORE FOR ELASTIC PIN

ZYLINDERBODEN MIT SPANNHÜLSE BOHRUNG

TAPÓN TALADRADO PARA PASADOR ELÁSTICO

ФЛЮС ЭЛАСТИЧНОЙ ВТУЛКИ С ОТВЕРСТИЯМИ

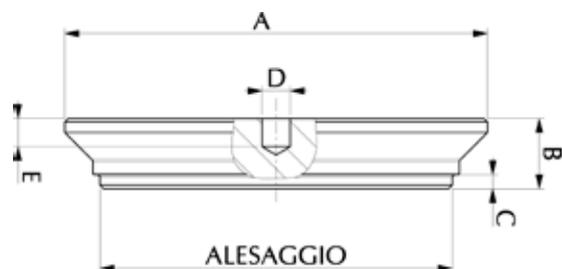

Art./Ref.	Alesaggio/Bore	Misura A mm/ A size mm	Misura B mm/ B size mm	Misura C mm/ C size mm	Misura D mm/ D size mm	Misura E mm/ E size mm	Peso kg/Weight kg
78708	25	35	10	2	4	6	0,04
78709	30	40	10	2	4	6	0,06
78731	32	40	10	2	4	6	0,06
78732	35	45	10	2	4	6	0,10
78733	40	50	10	2	4	6	0,13
78734	45	55	10	2	4	6	0,15
78768	50	60	10	2	4	6	0,19
78769	55	65	12	2	4	6	0,25
78787	60	70	12	2	4	6	0,33
78788	63	73	12	2	4	6	0,40
78789	65	75	12	2	4	6	0,40
78791	70	80	12	2	4	6	0,43
78792	75	85	12	2	4	6	0,50
78793	80	90	12	2	4	6	0,55
78794	80	95	12	2	4	6	0,58
78796	85	100	15	2	4	6	0,59
78797	90	105	15	2	4	6	0,90
78798	100	115	15	2	4	6	1,05
78799	110	125	15	2	4	6	1,00
78809	110	130	15	2	4	6	1,00
78821	120	140	20	2	4	6	1,30
78822	125	145	20	4	4	6	1,45

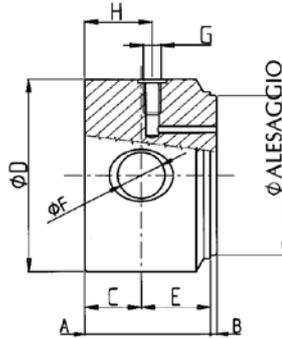
FONDELLO CON FORO E ATTACCO ENTRATA OLIO
FOND PERCE ET ENTREE HUILE
BOTTOM WITH BORE AND OIL INLET
ZYLINDERBODEN MIT BOHRUNG UND ÖLEINLASS
TAPÓN DE CIERRE TALADRADO Y ATAQUE CON ENTRADA ACEITE
ФЛЮС С ОТВЕРСТИЯМИ И КРЕПЛЕНИЕМ ДЛЯ ВХОДА МАСЛА

Materiale: acciaio fe37 UNI 5334
Materials: STEEL 4360-40D BS

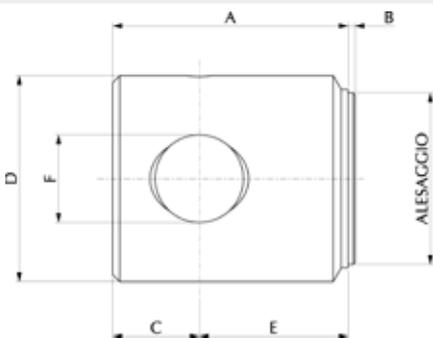
Art./Ref.	Alesaggio/ Bore	Misura A mm/ A size mm	Misura B mm/ B size mm	Misura C mm/ C size mm	Misura D mm/ D size mm	Misura E mm/ E size mm	Misura F mm/ F size mm	Misura G mm/ G size mm	Misura H mm/ H size mm	Peso kg/ Weight kg
2F032CDE	32	54	2	17	40	37	16,5	1/4"	30	0,33
78824	35	54	2	17	40	37	16,5	1/4"	30	0,53
2F040CDE	40	54	2	19	50	35	20,5	3/8"	30	0,69
2F050CDE	50	68	2	25	60	43	25,5	3/8"	38	1,25
2F060CDE	60	68	2	25	70	43	25,5	3/8"	38	1,78
2F070CDE	70	68	2	25	80	43	30,5	3/8"	38	1,88
2F080CDE	80	68	2	25	90	43	30,5	3/8"	38	2,89
2F09030CDE	90	73	2	25	105	48	30,25	1/2"	47	3,8
2FOA1CDE	100	79	2	34	115	45	30,5	1/2"	47	5,81
2FOA135CDE	100	73	2	30	115	43	35,25	1/2"	47	5,85

FONDELLO CON FORO
FOND PERCE
BOTTOM WITH BORE
ZYLINDERBODEN MIT BOHRUNG
TAPÓN DE CIERRE TALADRADO
ФЛЮС С ОТВЕРСТИЯМИ

Art./Ref.	Alesaggio/ Bore	Misura A mm/ A size mm	Misura B mm/ B size mm	Misura C mm/ C size mm	Misura D mm/ D size mm	Misura E mm/ E size mm	Misura F mm/ F size mm	Peso kg/ Weight kg
78823	25	28	2	12	35	16	12	0,25
2FS32CDE	32	40	2	17	40	23	16	0,34
2FS35CDE	35	40	2	17	40	23	16,2	0,45
2FS40CDE	40	54	2	19	50	35	20,5	0,71
2FS50CDE	50	68	2	25	60	43	25,5	1,28
2FS5020CDE	50	47	2	20	60	27	20,5	1,30
2FS60CDE	60	68	2	25	70	43	25,5	1,80
2FS6020CDE	60	68	2	25	70	43	20,5	1,8
2FS70CDE	70	68	2	25	80	43	30,5	1,92
2FS7025CDE	70	68	2	25	80	43	25,5	1,92
2FS80CDE	80	68	2	25	95	43	30,5	2,98
2FSA1CDE	100	79	2	34	115	45	30,5	5,82
2FSA135CDE	100	68	2	30	115	38	35,25	5,95

TUBI TRAFILATI COMMERCIALI PER CILINDRI

TUBES ACIER POUR VERINS

STEEL TUBES FOR CYLINDERS

STAHLROHRE FÜR ZYLINDER

TUBO DE ACERO PARA CILINDROS

ТРУБКИ ВОЛОЧИЛЬНЫЕ ДЛЯ ГИДРОЦИЛИНДРОВ

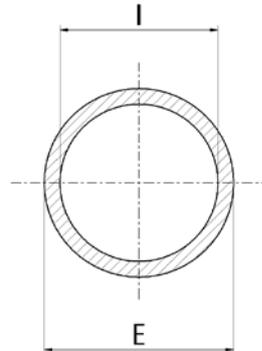
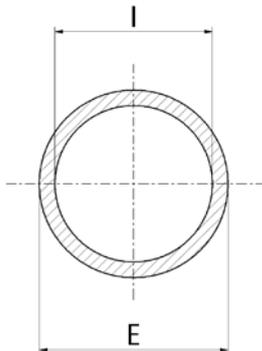

Art./Ref.	Misura E mm/ E size mm	Misura l mm/ l size mm	Note/Notes
06642	50	40	L. 3MT
06643	60	50	L. 3MT
06644	70	60	L. 3MT
06645	73	63	L. 3MT
06646	80	70	L. 3MT
06647	95	80	L. 3MT
12486	90	80	L. 3MT

BARRE CROMATE COMMERCIALI PER CILINDRI

BARRES CHROMEES POUR VERINS

STEEL CHROMED BARS FOR CYLINDERS

CHROMSTANGE FÜR ZYLINDER

BARRA CROMADA

ПРУТЫ ХРОМИРОВАННЫЕ ДЛЯ ГИДРОЦИЛИНДРОВ

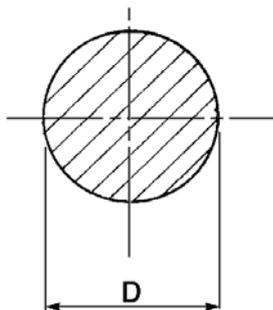

Art./Ref.	Misura D mm/D size mm	Note/Notes
06635	20	L. 3MT
06636	25	L. 3MT
06637	30	L. 3MT
06638	35	L. 3MT
06639	40	L. 3MT
0CV503M	50	L. 3MT
0CV603M	60	L. 3MT

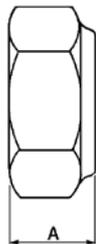
DADI AUTOBLOCCANTI
ECROUS FREINES
LOCKNUTS
SELBSTSPERRENDE MUTTERN
TUERCA AUTOBLOCANTES
ГАЙКИ САМОБЛОКИРУЮЩИЕ

Art./Ref.	Filetto/Thread	Misura A mm/A size mm	Note/Notes
ODA14	14X1,5	14	CHIAVE 22
06662	18X1,5	16	CHIAVE 27
ODA20	20X1,5	23	CHIAVE 30
ODA22	22X1,5	25	CHIAVE 32
ODA27	27X2	23	CHIAVE 41
ODA30	30X2	25	CHIAVE 46
ODA33	33X2	35	CHIAVE 50

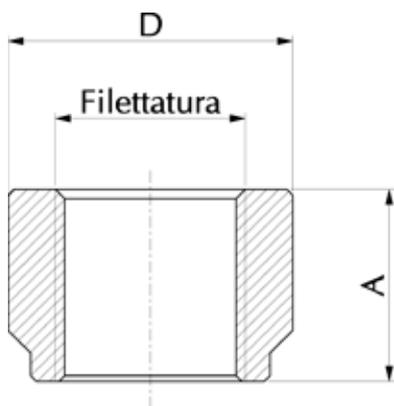
BORCHIE FILETTATE PER ATTACCHI CILINDRI
DOUILLES FILETEES POUR ATTACHE DE VERIN
THREADED BUSHING FOR CYLINDERS
GEWINDESTÜTZEN FÜR ZYLINDER
TACHÓN ROSCADO DE ATAQUE DEL CILINDRO
НАКЛАДКИ С РЕЗЬБОЙ ДЛЯ КРЕПЛЕНИЙ ЦИЛИНДРОВ

Art./Ref.	Filetto/Thread	Misura A mm/A size mm	Misura D mm/D size mm	Peso kg/Weight kg
OBA114-01	1/4"	16	24	0,03
OBA318-01	3/8"	17	26	0,04
OBA112-01	1/2"	18	32	0,05
OBA314-01	3/4"	20	40	0,10
OBA100-01	1"	25	47	0,15
OBA1415-01	14X1,5	16	24	0,03
OBA1615-01	16X1,5	17	26	0,05
OBA1815-01	18X1,5	18	28	0,05
OBA2215-01	22X1,5	18	32	0,06

BORCHIE FILETATE CON ATTACCO LATERALE

BOSSAGE CANELÉE AVEC ATTAQUE LATERAL
 THREADED BUSHING WITH SIDE CONNECTOR
 GEWINDESTUETZEN MIT SEITLICHEM ANSCHLUSS
 ENTRADAS ROSCADAS CON ATAQUE LATERAL
 БОЙКИ РЕЗЬБОВЫЕ С БОКОВЫМ КРЕПЛЕНИЕМ

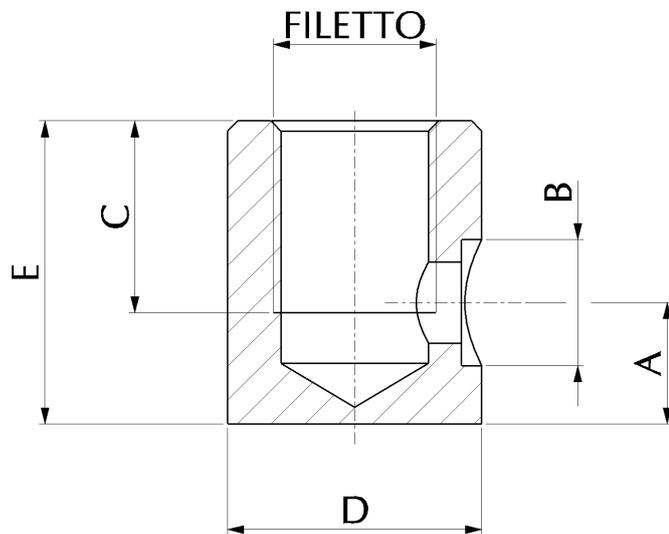

Art./Ref.	Filetto/Thread	Misura A mm/A size mm	Misura B mm/B size mm	Misura C mm/C size mm	Misura D mm/D size mm	Misura E mm/E size mm
OBA10A	1/4"	10	8/10	16	22	25
OBA10	3/8"	12	8/10	17	25	30
OBA12	3/8"	12	12	17	25	30
OBA14	3/8"	12	14	17	25	30
OBA12A	1/2"	12	12	18	30	46
OBA14A	1/2"	12	14	18	30	46

BORCHIA FILETTATA PER VALVOLA

DOUILLE FILETE POUR CLAPET
 THREADED BUSHING FOR VALVE
 GEWINDEZÜTZE FÜR VENTIL
 TACHÓN ROSCADO PARA VALVULA
 НАКЛАДКА С РЕЗЬБОЙ ДЛЯ КЛАПАНА

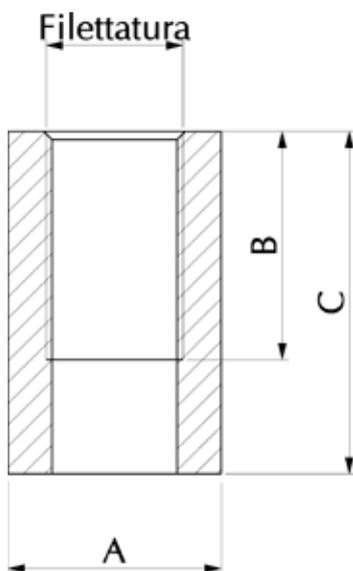

Art./Ref.	Filetto/Thread	Misura A mm/A size mm	Misura B mm/B size mm	Misura C mm/C size mm	Peso kg/Weight kg
80751	1/4"	22	27	40	0,09
80752	3/8"	26	28	42	0,12
80753	1/2"	30	33	48	0,16

FILTRI SFIATO PER CILINDRI
BOUCHON DE PURGEUR À HUILE
OIL FILLING PLUG AND BREATHER
STOPFER FÜR ÖLEINFÜLLUNG UND ENTLÜFTUNG
FILTROS DE CILINDRO
ФИЛЬТРЫ ВЕНТИЛЯЦИОННЫЕ ДЛЯ ГИДРОЦИЛИНДРОВ

Art./Ref.	Filetto/Thread
04610	1/4"
04611	3/8"
04661	1/2"

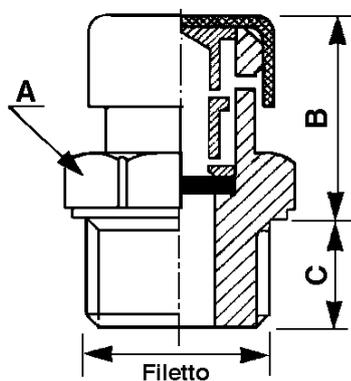
TAPPO SFIATO CON PROTEZIONE
BOUCHON RENIFLARD AVEC PROTECTION
BREATHER PLUG WITH PROTECTION
ENTLÜFTUNGSSCHRAUBE
TAPÓN RESPIRADERO CON PROTECCIÓN
ПРОБКА ВАНТУЗНАЯ С ЗАЩИТОЙ

Art./Ref.	Filetto/Thread	Misura A mm/A size mm	Misura B mm/B size mm	Misura C mm/C size mm
31801	1/4"	17	20	9
31802	3/8"	20	19	9
31803	1/2"	24	19	10

FORCELLE A SILDARE FORATE PER STELO E FONDELLO

CHAPPES A SOUDER AVEC TROU

WELD-ON BORED FORKS

ZYLINDERGABELN ZU ANSCHWEISSUNG MIT BOHRUNG

HORQUILLA PERFORADA A SOLDAR

ВИЛКИ СВАРОЧНЫЕ С ОТВЕРСТИЯМИ ДЛЯ ШТОКА И ФЛЮСА

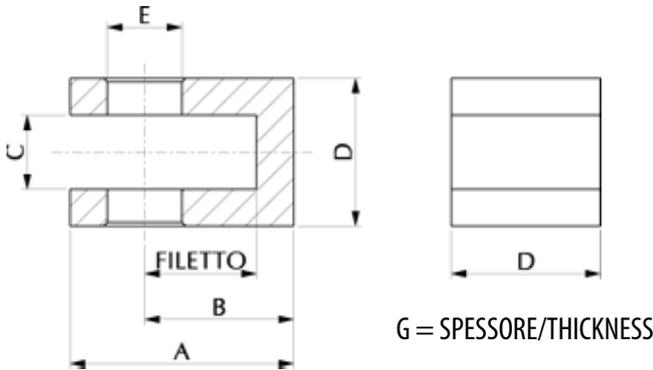

Art./Ref.	Misura A mm/ A size mm	Misura B mm/ B size mm	Misura C mm/ C size mm	Misura D mm/ D size mm	Misura E mm/ E size mm	Misura G mm/ G size mm	Filetto/ Thread	Peso kg/ Weight kg
OFR16	50	34	16	35	16	9,5	24	0,28
OFR20	60	40	20	40	20	10	30	0,39
OFR25	65	45	25	50	25	12,5	30	0,70
OFR30	75	50	30	60	30	15	35	1,10
OFR35	85	55	35	70	35	17,5	40	1,45

FORCELLE PER BRACCI DI SOLLEVAMENTO

CHAPPES POUR BRAS DE RELEVAGE

FORK FOR HYDRAULIC LEVELLING ARMS

GABELN FÜR HYDRAULISCHE SEITLICHE HUBSTREBEN

HORQUILLAS PARA BRAZOS HIDRAULICOS LATERALES DE ELEVACIÓN

ВИЛКИ ДЛЯ ПОДЪЕМНЫХ РЫЧАГОВ

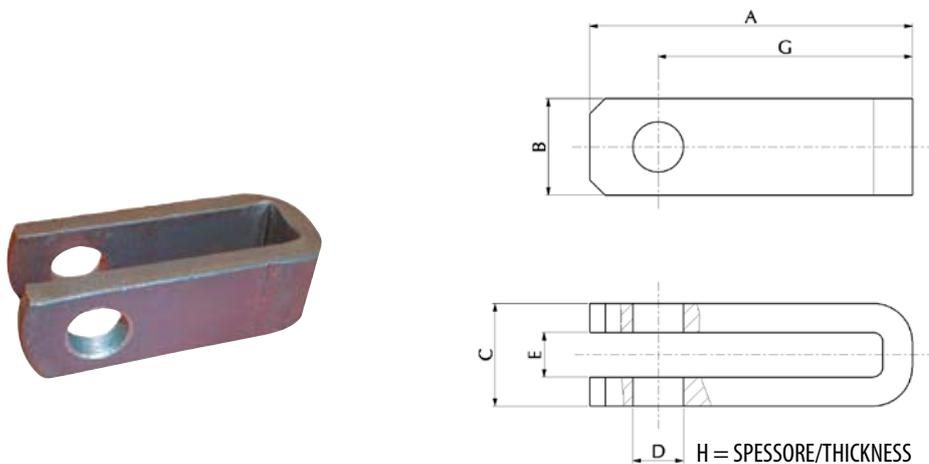

Art./Ref.	Misura A mm/A size mm	Misura B mm/B size mm	Misura C mm/C size mm	Misura D mm/D size mm	Misura E mm/E size mm	Misura G mm/G size mm	Misura H mm/H size mm
OFC4650	87	50	70	22	46	62	12
OFC2193	92	50	45	26	21	70	12
OFC2315	160	50	53	22	23	130	15
OFC2316	165	50	53	26	23	130	15
OFC3810	155	60	68	26	38	125	15
OFC4325	170	60	73	28	43	140	15
OFC2595	135	50	55	24	25	110	15
OFC5025	165	60	70	28,4	50	135	10
OFC3295	135	60	62	25,5	32	110	15
OFC3028	165	60	54	25	30	140	12
OFC2546	80	45	50	18	25	58	12,5
OFC3875	115	50	68	22	38	90	15
OFC3390	135	60	63	26	33	105	15
OFC5145	90	60	81	28	51	60	15
OFC4595	135	50	75	24	45	110	15

SUPPORTO A BOCCOLA

FIXATION A DOUILLE
 PISTON BUSCHING END
 KOLBENANSCHLUSSBUCHSE
 SOPORTE A CASQUILLAS
 ОПОРА ВТУЛОЧНАЯ

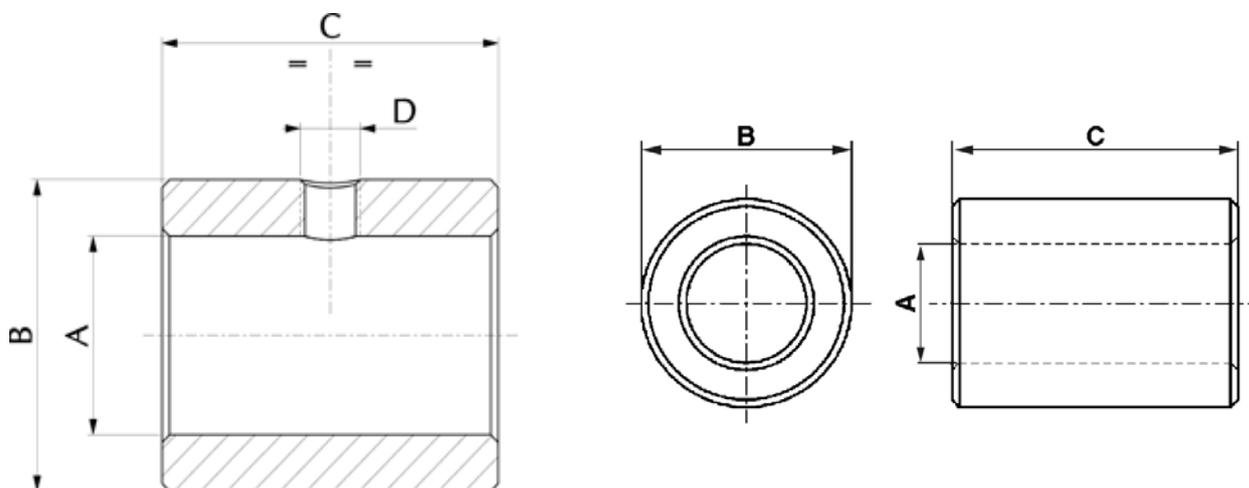

Art./Ref.	Misura A mm/A size mm	Misura B mm/B size mm	Misura C mm/C size mm	Misura D mm/D size mm	Peso kg/Weight kg
0BM1635	16	35	30		0,15
0BB1635	16	35	60		0,36
0BM2040	20	40	40		0,34
0BB2040	20	40	70		0,56
0BM2550	25	50	50		0,60
0BB2550	25	50	80		0,96
80754	25	50	90		1,02
80755	25	60	150		1,30
0BM3060	30	60	60		0,99
0BB3060	30	60	110		1,80
80756	40	70	70		1,60
80757	40	70	130		2,65
2BP1635CDE	16	30	35	M6	0,18
2BP2040CDE	20,5	35	40	M6	0,29
2BP2050CDE	20,5	40	50	M6	0,35
2BP2545CDE	25,5	40	45	M8X1	0,56
2BP3055CDE	30,5	50	55	M8X1	0,97
2BP3070CDE	30,5	65	70	M10X1	1,30

SEDE PER SNODO SFERICO RADIALE A SALDARE

LOGEMENT POUR ROTULE A SOUDER

SEAT FOR RADIAL BALL JOINT

SITZ FÜR RADIALKUGELGELENKE

ALOJAMIENTO PARA COJINETE DE SOLDAR

МЕСТО ДЛЯ РАДИАЛЬНЫХ СФЕРИЧНЫХ СВАРОЧНЫХ ШАРНИРОВ

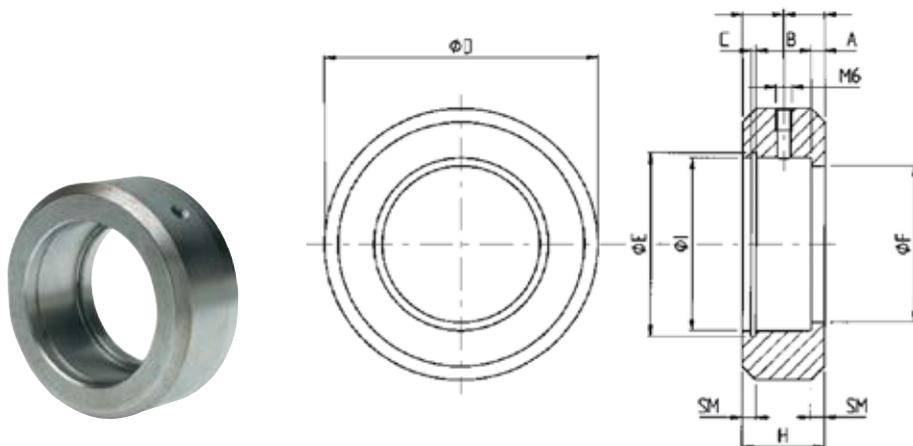

Art./Ref.	Misura A mm/ A size mm	Misura B mm/ B size mm	Misura C mm/ C size mm	Misura D mm/ D size mm	Misura E mm/ E size mm	Misura F mm/ F size mm	Misura H mm/ H size mm	Misura I mm/ I size mm	Note/Notes
0ANSE20	3,5	12,05	1,6	50	36	31	19,5	35,05	SNODO 0GE020DO-LO
0ANSE25	4	16,05	1,85	70	43,2	38	24	42,05	SNODO 0GE025DO-LO
0ANSE30	5	18,05	1,85	75	48,2	43	28	47,05	SNODO 0GE030DO
0ANSE32	5	18,05	1,85	80	53,5	45	28	52,05	SNODO 0GE032LO
0ANSE35	6,5	20,05	2,15	80	56,5	50	33	55,05	SNODO 0GE035DO
0ANSE40	6,5	22,05	2,15	95	63,5	57	35	62,05	SNODO 0GE040DO-LO
0ANSE45	6,50	25,05	2,65	100	69,5	63	38	68,05	SNODO 0GE045DO
0ANSE50	6	28,05	2,65	110	77,8	70	40	75,05	SNODO 0GE050DO-LO

OCCHIO FISSO

OEIL FIXE

FIXED EYE

FESTAUGE

OJO FIJO

ПРОУШИНА ФИКСИРОВАННАЯ

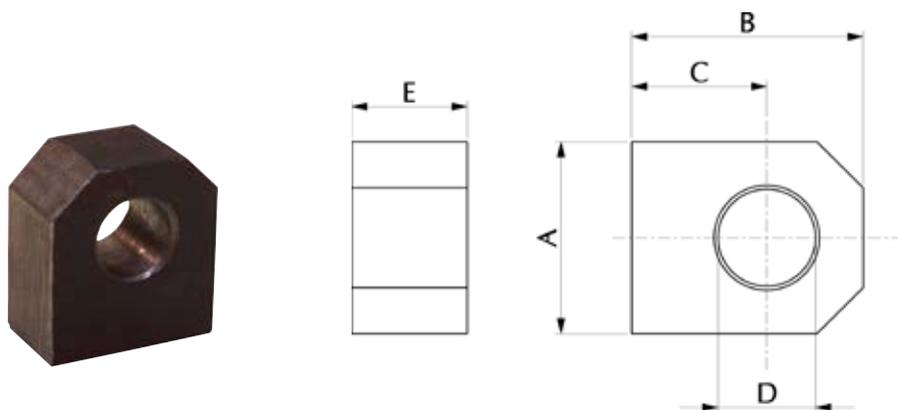

Art./Ref.	Misura A mm/A size mm	Misura B mm/B size mm	Misura C mm/C size mm	Misura D mm/D size mm	Misura E mm/E size mm	Peso kg/Weight kg
80758	50	100	40	12,2	8	0,15
00F1625	35	42	25	16,2	20	0,18
80759	50	100	50	16,2	10	0,35
00F2030	45	50	30	20,25	25	0,40
80760	50	100	60	20,25	30	0,50
00F2535	50	60	35	25,25	30	0,56
80761	60	75	45	30,25	35	0,97
80762	70	90	55	35,25	40	1,10

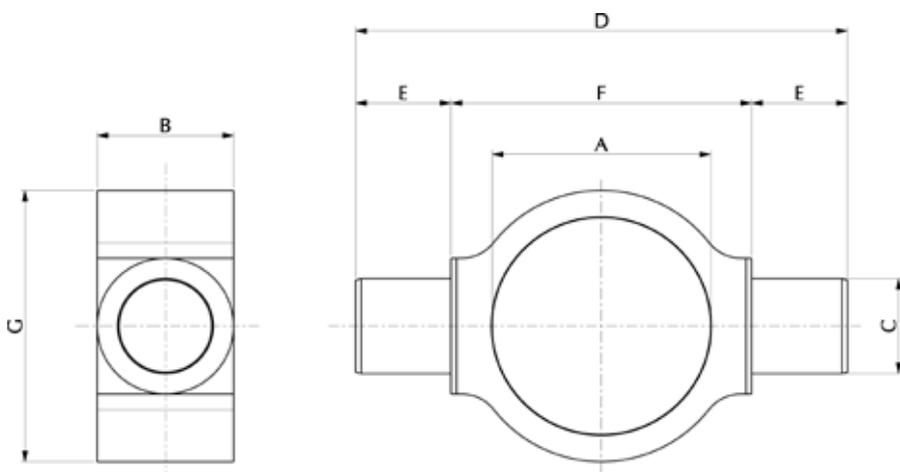
BASCULA A SILDARE
BASCULE À SOUDER
WELD-ON TRUNNION
SCHWENKZAPFEN ZU ANSCHWEISSEN
PERNO BASCULANTE A SOLDAR
ТОЧКА ОПОРЫ СВАРОЧНАЯ

Art./Ref.	Misura A mm/ A size mm	Misura B mm/ B size mm	Misura C mm/ C size mm	Misura D mm/ D size mm	Misura E mm/ E size mm	Misura F mm/ F size mm	Misura G mm/ G size mm	Peso kg/ Weight kg
79139	50	30	20	110	20	70	65	0,52
80744	60	35	25	130	25	80	75	0,79
80745	70	45	30	160	30	100	90	1,57
80746	80	50	35	180	35	110	100	2,03
80747	95	55	40	195	40	115	115	2,40
80748	105	60	45	215	45	125	125	3,40
80749	115	70	50	245	50	145	145	5,30
80750	140	80	60	290	60	170	170	7,70